

OTD-18/0001

▼
**Solvent Cleaning and PE
Joining Procedures**

Prepared by:
Gas Technology Institute
Des Plaines, Illinois

January 2018

GTI-OTD FINAL REPORT

Public Version OTD 5.16.a

Solvent Cleaning and PE Joining Procedures

Reporting Period:

January 1, 2016 through October 31, 2017

Report Issued:

January 31, 2018

Project Investors:

OTD Members

GTI Project Manager:

Natalya Bates

Project Manager

847-768-0953

natalya.bates@gastechnology.org

GTI Technical Contact:

Oren Lever

Principal Engineer

847-768-0668

oren.lever@gastechnology.org

GTI Team Members:

Oren Lever, Travis Cottle, Pete Mulligan, Jarrod Bullen, Joseph Irwin, Brian Miller, Dennis Jarnecke

Gas Technology Institute

1700 S. Mount Prospect Rd.

Des Plaines, Illinois 60018

www.gastechnology.org

Legal Notice

This information was prepared by Gas Technology Institute (“GTI”) for Operations Technology Development (OTD).

Neither GTI, the members of GTI, the Sponsor(s), nor any person acting on behalf of any of them:

- a. Makes any warranty or representation, express or implied with respect to the accuracy, completeness, or usefulness of the information contained in this report, or that the use of any information, apparatus, method, or process disclosed in this report may not infringe privately-owned rights. In as much as this project is experimental in nature, the technical information, results, or conclusions cannot be predicted. Conclusions and analysis of results by GTI represent GTI's opinion based on inferences from measurements and empirical relationships, which inferences and assumptions are not infallible, and with respect to which competent specialists may differ.*
- b. Assumes any liability with respect to the use of, or for any and all damages resulting from the use of, any information, apparatus, method, or process disclosed in this report; any other use of, or reliance on, this report by any third party is at the third party's sole risk.*
- c. The results within this report relate only to the items tested.*

Table of Contents

Legal Notice	2
Table of Contents.....	3
Table of Figures	6
List of Tables	13
List of Acronyms	14
Executive Summary	15
Introduction	17
Sponsor Survey	19
Testing.....	21
Pipe Contamination Apparatus.....	21
Preliminary Contamination Removal Testing.....	22
Contamination Removal and Electrofusion Testing	32
Discussion and Conclusions	42
Suggested Scraping Procedure Guideline.....	45
Potential Future Work	48
Appendix A – Pipe Contamination Apparatus.....	49
Appendix B – Post Decohesion FTIR Test Results	54
172318-001.....	55
172318-002.....	56
172318-003.....	57
172318-004.....	58
172318-005.....	59
172318-006.....	60
172318-007.....	61
172318-008.....	62
172318-009.....	63
172318-010.....	64
172318-011.....	65
172318-012.....	66
172318-013.....	67
172318-014.....	68
172318-015.....	69
172318-016.....	70

172318-017.....	71
172318-018.....	72
172318-019.....	73
172318-020.....	74
172318-021.....	75
172318-022.....	76
172318-023.....	77
172318-024.....	78
172318-025.....	79
172318-026.....	80
172318-027.....	81
172318-028.....	82
172318-029.....	83
172318-031.....	84
172318-033.....	85
172318-034.....	86
172318-035.....	87
172318-036.....	88
172318-037.....	89
172318-038.....	90
172318-039.....	91
172318-040.....	92
172318-041.....	93
172318-042.....	94
172318-042A.....	95
172318-043.....	96
172318-044.....	97
172318-045.....	98
172318-046.....	99
172318-047.....	100
172318-048.....	101
172318-049.....	102
172318-050.....	103
172318-051.....	104
172318-052.....	105

172318-053.....	106
172318-054.....	107
172318-055.....	108
172318-057.....	109
172318-058.....	110
172316-032.....	111
172316-033.....	112
172316-035.....	113
172316-036.....	114
172316-037.....	115
172316-038.....	116
172316-041.....	117
172316-042.....	118
172316-044.....	119
172316-045.....	120
172316-046.....	121
172316-047.....	122
172316-048.....	123
172316-049.....	124
172316-050.....	125
172316-051.....	126
172316-052.....	127
172316-053.....	128
172316-054.....	129
172316-055.....	130
172316-057.....	131
172316-058.....	132
172316-059.....	133
172316-060.....	134
172316-061.....	135
172316-063.....	136
172316-064.....	137
172316-065.....	138
172316-066.....	139
172316-067.....	140

172316-068.....	141
172316-069.....	142
172316-070.....	143
172316-071.....	144
172316-072.....	145
172316-073.....	146
172316-074.....	147
172316-075.....	148
172316-076.....	149
172316-077.....	150
172316-078.....	151
172316-079.....	152

Table of Figures

Figure 1. Overview of electrofusion process, with highlights of OTD project scopes	18
Figure 2. Tested cleaning tools	22
Figure 3. Post-cleaning FTIR spectra, contaminant=bentonite, solvent=91% isopropyl alcohol/9% distilled water	23
Figure 4. Post-cleaning FTIR spectra, contaminant=bentonite, solvent=99% isopropyl alcohol/1% distilled water	24
Figure 5. Post-cleaning FTIR spectra, contaminant=bentonite, solvent=acetone	25
Figure 6. Post-cleaning FTIR spectra, contaminant=silicone grease, solvent=91% isopropyl alcohol/9% distilled water	26
Figure 7. Post-cleaning FTIR spectra, contaminant=silicone grease, solvent=99% isopropyl alcohol/1% distilled water	27
Figure 8. Post-cleaning FTIR spectra, contaminant=silicone grease, solvent=acetone	28
Figure 9. Post-cleaning FTIR spectra, contaminant=talc, solvent=91% isopropyl alcohol/9% distilled water	29
Figure 10. Post-cleaning FTIR spectra, contaminant=talc, solvent=99% isopropyl alcohol/1% distilled water	30
Figure 11. Post-cleaning FTIR spectra, contaminant=talc, solvent=acetone	31
Figure 12. OEM 'Peeler', 2" IPS	32
Figure 13. Example of saddle decohesion test	33
Figure 14. Schematic of ISO 13956 type A2 decohesion test arrangement	34
Figure 15. Examples of saddle decohesion test results with their ductility bin score	35
Figure 16. Combined decohesion test results	36

Figure 17. Cleaning agent performance with different contaminants	37
Figure 18. Cleaning tool performance with different contaminants	38
Figure 19. Detailed results, 99% isopropyl alcohol	39
Figure 20. Detailed results, 91% isopropyl alcohol	40
Figure 21. Detailed results, acetone	41
Figure 22. Comparison of cleaning operations with bentonite contamination, overall decohesion results	43
Figure 23. Top-level generic scraping procedure incorporating best-practices	46
Figure 24. Schematic of cleaned areas for a saddle fitting	47
Figure 25. Schematic of cleaned areas for a coupling fitting.....	47
Figure 26. Figure A.1 from WIS-32-4-08	49
Figure 27. Pipe contamination apparatus	50
Figure 28. View of motorized strainer carriage, squeegee lowered onto strainer.....	51
Figure 29. 2" IPS pipe sample in place for contamination.....	52
Figure 30. Pipe contaminator control console and electronics box	53
Figure 31. Sample 172318-001, decohesion test result.....	55
Figure 32. Sample 172318-001, FTIR spectra from decohesion test result	55
Figure 33. Sample 172318-002, decohesion test result.....	56
Figure 34. Sample 172318-002, FTIR spectra from decohesion test result	56
Figure 35. Sample 172318-003, decohesion test result.....	57
Figure 36. Sample 172318-003, FTIR spectra from decohesion test result	57
Figure 37. Sample 172318-004, decohesion test result.....	58
Figure 38. Sample 172318-004, FTIR spectra from decohesion test result	58
Figure 39. Sample 172318-005, decohesion test result.....	59
Figure 40. Sample 172318-005, FTIR spectra from decohesion test result	59
Figure 41. Sample 172318-006, decohesion test result.....	60
Figure 42. Sample 172318-006, FTIR spectra from decohesion test result	60
Figure 43. Sample 172318-007, decohesion test result.....	61
Figure 44. Sample 172318-007, FTIR spectra from decohesion test result	61
Figure 45. Sample 172318-008, decohesion test result.....	62
Figure 46. Sample 172318-008, FTIR spectra from decohesion test result	62
Figure 47. Sample 172318-009, decohesion test result.....	63
Figure 48. Sample 172318-009, FTIR spectra from decohesion test result	63
Figure 49. Sample 172318-010, decohesion test result.....	64
Figure 50. Sample 172318-010, FTIR spectra from decohesion test result	64

Figure 51. Sample 172318-011, decohesion test result.....	65
Figure 52. Sample 172318-011, FTIR spectra from decohesion test result	65
Figure 53. Sample 172318-012, decohesion test result.....	66
Figure 54. Sample 172318-012, FTIR spectra from decohesion test result	66
Figure 55. Sample 172318-013, decohesion test result.....	67
Figure 56. Sample 172318-013, FTIR spectra from decohesion test result	67
Figure 57. Sample 172318-014, decohesion test result.....	68
Figure 58. Sample 172318-014, FTIR spectra from decohesion test result	68
Figure 59. Sample 172318-015, decohesion test result.....	69
Figure 60. Sample 172318-015, FTIR spectra from decohesion test result	69
Figure 61. Sample 172318-016, decohesion test result.....	70
Figure 62. Sample 172318-016, FTIR spectra from decohesion test result	70
Figure 63. Sample 172318-017, decohesion test result.....	71
Figure 64. Sample 172318-017, FTIR spectra from decohesion test result	71
Figure 65. Sample 172318-018, decohesion test result.....	72
Figure 66. Sample 172318-018, FTIR spectra from decohesion test result	72
Figure 67. Sample 172318-019, decohesion test result.....	73
Figure 68. Sample 172318-019, FTIR spectra from decohesion test result	73
Figure 69. Sample 172318-020, decohesion test result.....	74
Figure 70. Sample 172318-020, FTIR spectra from decohesion test result	74
Figure 71. Sample 172318-021, decohesion test result.....	75
Figure 72. Sample 172318-021, FTIR spectra from decohesion test result	75
Figure 73. Sample 172318-022, decohesion test result.....	76
Figure 74. Sample 172318-022, FTIR spectra from decohesion test result	76
Figure 75. Sample 172318-023, decohesion test result.....	77
Figure 76. Sample 172318-023, FTIR spectra from decohesion test result	77
Figure 77. Sample 172318-024, decohesion test result.....	78
Figure 78. Sample 172318-024, FTIR spectra from decohesion test result	78
Figure 79. Sample 172318-025, decohesion test result.....	79
Figure 80. Sample 172318-025, FTIR spectra from decohesion test result	79
Figure 81. Sample 172318-026, decohesion test result.....	80
Figure 82. Sample 172318-026, FTIR spectra from decohesion test result	80
Figure 83. Sample 172318-027, decohesion test result.....	81
Figure 84. Sample 172318-027, FTIR spectra from decohesion test result	81
Figure 85. Sample 172318-028, decohesion test result.....	82

Figure 86. Sample 172318-028, FTIR spectra from decohesion test result	82
Figure 87. Sample 172318-029, decohesion test result.....	83
Figure 88. Sample 172318-029, FTIR spectra from decohesion test result	83
Figure 89. Sample 172318-031, decohesion test result.....	84
Figure 90. Sample 172318-031, FTIR spectra from decohesion test result	84
Figure 91. Sample 172318-033, decohesion test result.....	85
Figure 92: Sample 172318-033, FTIR spectra from decohesion test result	85
Figure 93. Sample 172318-034, decohesion test result.....	86
Figure 94. Sample 172318-034, FTIR spectra from decohesion test result	86
Figure 95. Sample 172318-035, decohesion test result.....	87
Figure 96. Sample 172318-035, FTIR spectra from decohesion test result	87
Figure 97. Sample 172318-036, decohesion test result.....	88
Figure 98. Sample 172318-036, FTIR spectra from decohesion test result	88
Figure 99. Sample 172318-037, decohesion test result.....	89
Figure 100. Sample 172318-037, FTIR spectra from decohesion test result	89
Figure 101. Sample 172318-038, decohesion test result.....	90
Figure 102. Sample 172318-038, FTIR spectra from decohesion test result	90
Figure 103. Sample 172318-039, decohesion test result.....	91
Figure 104. Sample 172318-039, FTIR spectra from decohesion test result	91
Figure 105. Sample 172318-040, decohesion test result.....	92
Figure 106. Sample 172318-040, FTIR spectra from decohesion test result	92
Figure 107. Sample 172318-041, decohesion test result.....	93
Figure 108. Sample 172318-041, FTIR spectra from decohesion test result	93
Figure 109. Sample 172318-042, decohesion test result.....	94
Figure 110. Sample 172318-042, FTIR spectra from decohesion test result	94
Figure 111. Sample 172318-042A, decohesion test result	95
Figure 112. Sample 172318-042A, FTIR spectra from decohesion test result.....	95
Figure 113. Sample 172318-043, decohesion test result.....	96
Figure 114. Sample 172318-043, FTIR spectra from decohesion test result	96
Figure 115. Sample 172318-044, decohesion test result.....	97
Figure 116. Sample 172318-044, FTIR spectra from decohesion test result	97
Figure 117. Sample 172318-045, decohesion test result.....	98
Figure 118. Sample 172318-045, FTIR spectra from decohesion test result	98
Figure 119. Sample 172318-046, decohesion test result.....	99
Figure 120. Sample 172318-046, FTIR spectra from decohesion test result	99

Figure 121. Sample 172318-047, decohesion test result.....	100
Figure 122. Sample 172318-047, FTIR spectra from decohesion test result	100
Figure 123. Sample 172318-048, decohesion test result.....	101
Figure 124. Sample 172318-048, FTIR spectra from decohesion test result	101
Figure 125. Sample 172318-049, decohesion test result.....	102
Figure 126. Sample 172318-049, FTIR spectra from decohesion test result	102
Figure 127. Sample 172318-050, decohesion test result.....	103
Figure 128. Sample 172318-050, FTIR spectra from decohesion test result	103
Figure 129. Sample 172318-051, decohesion test result.....	104
Figure 130. Sample 172318-051, FTIR spectra from decohesion test result	104
Figure 131. Sample 172318-052, decohesion test result.....	105
Figure 132. Sample 172318-052, FTIR spectra from decohesion test result	105
Figure 133. Sample 172318-053, decohesion test result.....	106
Figure 134. Sample 172318-053, FTIR spectra from decohesion test result	106
Figure 135. Sample 172318-054, decohesion test result.....	107
Figure 136. Sample 172318-054, FTIR spectra from decohesion test result	107
Figure 137. Sample 172318-055, decohesion test result.....	108
Figure 138. Sample 172318-055, FTIR spectra from decohesion test result	108
Figure 139. Sample 172318-057, decohesion test result.....	109
Figure 140. Sample 172318-057, FTIR spectra from decohesion test result	109
Figure 141. Sample 172318-058, decohesion test result.....	110
Figure 142. Sample 172318-058, FTIR spectra from decohesion test result	110
Figure 143. Sample 172316-032, decohesion test result.....	111
Figure 144. Sample 172316-032, FTIR spectra from decohesion test result	111
Figure 145. Sample 172316-033, decohesion test result.....	112
Figure 146. Sample 172316-033, FTIR spectra from decohesion test result	112
Figure 147. Sample 172316-035, decohesion test result.....	113
Figure 148. Sample 172316-035, FTIR spectra from decohesion test result	113
Figure 149. Sample 172316-036, decohesion test result.....	114
Figure 150. Sample 172316-036, FTIR spectra from decohesion test result	114
Figure 151. Sample 172316-037, decohesion test result.....	115
Figure 152. Sample 172316-037, FTIR spectra from decohesion test result	115
Figure 153. Sample 172316-038, decohesion test result.....	116
Figure 154. Sample 172316-038, FTIR spectra from decohesion test result	116
Figure 155. Sample 172316-041, decohesion test result.....	117

Figure 156. Sample 172316-041, FTIR spectra from decohesion test result	117
Figure 157. Sample 172316-042, decohesion test result.....	118
Figure 158. Sample 172316-042, FTIR spectra from decohesion test result	118
Figure 159. Sample 172316-044, decohesion test result.....	119
Figure 160. Sample 172316-044, FTIR spectra from decohesion test result	119
Figure 161. Sample 172316-045, decohesion test result.....	120
Figure 162. Sample 172316-045, FTIR spectra from decohesion test result	120
Figure 163. Sample 172316-046, decohesion test result.....	121
Figure 164. Sample 172316-046, FTIR spectra from decohesion test result	121
Figure 165. Sample 172316-047, decohesion test result.....	122
Figure 166. Sample 172316-047, FTIR spectra from decohesion test result	122
Figure 167. Sample 172316-048, decohesion test result.....	123
Figure 168. Sample 172316-048, FTIR spectra from decohesion test result	123
Figure 169. Sample 172316-049, decohesion test result.....	124
Figure 170. Sample 172316-049, FTIR spectra from decohesion test result	124
Figure 171. Sample 172316-050, decohesion test result.....	125
Figure 172. Sample 172316-050, FTIR spectra from decohesion test result	125
Figure 173. Sample 172316-051, decohesion test result.....	126
Figure 174. Sample 172316-051, FTIR spectra from decohesion test result	126
Figure 175. Sample 172316-052, decohesion test result.....	127
Figure 176. Sample 172316-052, FTIR spectra from decohesion test result	127
Figure 177. Sample 172316-053, decohesion test result.....	128
Figure 178. Sample 172316-053, FTIR spectra from decohesion test result	128
Figure 179. Sample 172316-054, decohesion test result.....	129
Figure 180. Sample 172316-054, FTIR spectra from decohesion test result	129
Figure 181. Sample 172316-055, decohesion test result.....	130
Figure 182. Sample 172316-055, FTIR spectra from decohesion test result	130
Figure 183. Sample 172316-057, decohesion test result.....	131
Figure 184. Sample 172316-057, FTIR spectra from decohesion test result	131
Figure 185. Sample 172316-058, decohesion test result.....	132
Figure 186. Sample 172316-058, FTIR spectra from decohesion test result	132
Figure 187. Sample 172316-059, decohesion test result.....	133
Figure 188. Sample 172316-059, FTIR spectra from decohesion test result	133
Figure 189. Sample 172316-060, decohesion test result.....	134
Figure 190. Sample 172316-060, FTIR spectra from decohesion test result	134

Figure 191. Sample 172316-061, decohesion test result.....	135
Figure 192. Sample 172316-061, FTIR spectra from decohesion test result	135
Figure 193. Sample 172316-063, decohesion test result.....	136
Figure 194. Sample 172316-063, FTIR spectra from decohesion test result	136
Figure 195. Sample 172316-064, decohesion test result.....	137
Figure 196. Sample 172316-064, FTIR spectra from decohesion test result	137
Figure 197. Sample 172316-065, decohesion test result.....	138
Figure 198. Sample 172316-065, FTIR spectra from decohesion test result	138
Figure 199. Sample 172316-066, decohesion test result.....	139
Figure 200. Sample 172316-066, FTIR spectra from decohesion test result	139
Figure 201. Sample 172316-067, decohesion test result.....	140
Figure 202. Sample 172316-067, FTIR spectra from decohesion test result	140
Figure 203. Sample 172316-068, decohesion test result.....	141
Figure 204. Sample 172316-068, FTIR spectra from decohesion test result	141
Figure 205. Sample 172316-069, decohesion test result.....	142
Figure 206. Sample 172316-069, FTIR spectra from decohesion test result	142
Figure 207. Sample 172316-070, decohesion test result.....	143
Figure 208. Sample 172316-070, FTIR spectra from decohesion test result	143
Figure 209. Sample 172316-071, decohesion test result.....	144
Figure 210. Sample 172316-071, FTIR spectra from decohesion test result	144
Figure 211. Sample 172316-072, decohesion test result.....	145
Figure 212. Sample 172316-072, FTIR spectra from decohesion test result	145
Figure 213. Sample 172316-073, decohesion test result.....	146
Figure 214. Sample 172316-073, FTIR spectra from decohesion test result	146
Figure 215. Sample 172316-074, decohesion test result.....	147
Figure 216. Sample 172316-074, FTIR spectra from decohesion test result	147
Figure 217. Sample 172316-075, decohesion test result.....	148
Figure 218. Sample 172316-075, FTIR spectra from decohesion test result	148
Figure 219. Sample 172316-076, decohesion test result.....	149
Figure 220. Sample 172316-076, FTIR spectra from decohesion test result	149
Figure 221. Sample 172316-077, decohesion test result.....	150
Figure 222. Sample 172316-077, FTIR spectra from decohesion test result	150
Figure 223. Sample 172316-078, decohesion test result.....	151
Figure 224. Sample 172316-078, FTIR spectra from decohesion test result	151
Figure 225. Sample 172316-079, decohesion test result.....	152

Figure 226. Sample 172316-079, FTIR spectra from decohesion test result 152

List of Tables

Table 1. Summary of survey responses 19
Table 2. List of tested contaminants, cleaning agents, and cleaning tools.....21

List of Acronyms

CTS	Copper Tube Size
DI water	Deionized water
DoE	Design of Experiment
EF	Electrofusion
FTIR-ATR	Fourier Transform Infrared – Attenuated Total Reflectance
GTI	Gas Technology Institute
HDD	Horizontal Directional Drilling
HDPE	High Density Polyethylene
ID	Inner Diameter
IPA	Isopropyl Alcohol
IPS	Iron Pipe Size
ISO	International Organization for Standardization
MDPE	Medium Density Polyethylene
OD	Outer Diameter
OTD	Operations Technology Development
PE	Polyethylene
QC	Quality Control
SCG	Slow Crack Growth
SEM	Scanning Electron Microscope
UV	Ultraviolet

Executive Summary

Recent events have raised concern regarding fusion procedures and more specifically pipe preparation and cleaning procedures used by utilities and the protocols used to perform and qualify PE joining procedures. Additionally, recent cases of PE fusion joint failure investigated by GTI have found surface contamination to be the root cause of the failures, despite proper scraping of the pipe.

The work done in this project follows up and complements on the work performed in OTD Project 2.14.e *Guidelines/Best Practices for Scraping PE Pipe and Fittings* (highlighted in green in **Figure 1**). As can be seen in **Figure 1**, these two projects together cover the core pipe surface preparation processes. While OTD Project 2.14.e focused on the scraping/peeling performance of several common scrapers and peelers, this project has focused on the effectiveness of solvent cleaning in removal of surface contaminants.

The focus of this project was to test the performance of commonly used solvents and cleaning tools in terms of removal of contamination (talc powder, bentonite powder, and silicone grease) on PE pipe. Based on the sponsor survey and additional interaction with the project sponsors, a test matrix was developed that was comprised of 120 contamination removal/fusion test runs with electrofusion saddle fittings. The test matrix covered all combinations of the contaminants (talc powder, bentonite powder, silicone grease), cleaning agents (99% isopropyl alcohol, 91% isopropyl alcohol, acetone), and cleaning tools (lint-free wipe, cotton cloth rag, paper towel). Each combination was tested four times – twice on MDPE pipe and twice on HDPE pipe. Preliminary contamination removal tests on pipe rings, separate from the 120 contamination removal/fusion tests, were first conducted to get baseline data of the cleaning effectiveness of each combination of cleaning agent and cleaning tool with each contaminant.

The testing results have led to the following observations:

- The preliminary contamination removal tests on non-scraped pipe rings indicated that solvent cleaning is fundamentally effective at removing talc and bentonite powders on a relatively small and smooth surface.
- Silicone grease is particularly difficult to remove regardless of solvent and cleaning tool combination.
- The contamination removal/fusion tests indicate that in pipe cleaning scenarios any given wiping pass will not uniformly remove surface contamination.
 - The variability in cleaning is due to OD surface roughness, non-uniform wiping contact, physical variability of the cleaning tool, and contaminant distribution on the surface.
- Solvent cleaning will remove loose contamination such that the pipe will look clean.
- The pipe cleaning protocol employed in this project produced highly variable decohesion test results, and no 100% ductile joints.

The above observations lead to the following conclusions and recommendations:

- Solvent cleaning should be used to remove loose dirt and the bulk of surface contaminants before scraping.
 - This is further supported by the scraping-only test results from OTD Project 2.14.e *Guidelines/Best Practices for Scraping PE Pipe and Fittings*, shown in **Figure 22**.
- More than a single wiping pass should be required due to the variability in contamination removal of any single pass.
 - Each subsequent wiping pass should be within the area of the preceding wiping pass to avoid reintroduction of contamination from outside of the first wiping pass area.
- Any wiping pass should be made with a new cleaning tool to avoid reintroduction of contamination from a used cleaning tool.

- Any wiping pass should be made in the same single direction to avoid or minimize spreading of contamination that does not get removed by the current or previous pass.

Based on the inconsistency in solvent-cleaning's contamination removal, as observed in this project's testing, it is not clear if post-scraping solvent cleaning will be sufficiently effective at removing contaminants introduced after scraping. Additional testing is required to resolve the acceptability of post-scraping solvent cleaning – specifically, multiple wiping passes, water washing, and degree of contamination need to be evaluated.

The findings in this project and OTD Project 2.14.e *Guidelines/Best Practices for Scraping PE Pipe and Fittings* lead to the suggestion of a preparation technique where the pipe is thoroughly washed and cleaned prior to scraping and where the time between scraping and assembling of the fitting is minimized. The critical contamination avoidance aspects of the proposed procedure are (in chronological order):

1. Water-wash of pipe (exceeding the area to be scraped).
2. Solvent cleaning of the pipe with a specific wiping technique (exceeding area to be scraped, but within the water-washed area).
3. Scraping of the pipe **immediately after** solvent cleaning (within the solvent-cleaned area).
4. Assembly of the fitting and performing the fusion **immediately after scraping**.

This proposed procedure, which was also included in the final report of OTD Project 2.14.e, is detailed in this report on **Page 45**.

Overall, the various test results of this project and the results from OTD Project 2.14.e lend support the observation that to achieve successful PE fusions, best practices should be adopted in conjunction with **thorough operator training with specific attention to prevention of contamination** of the fusion areas of the pipe and fitting.

General notes on PE fusion and contamination

PE fusion is a stochastic process where two molten interfaces are brought into contact such that upon cooling and solidification the interfaces co-crystallize to form a ductile welded area. This fusion process is normally robust within a relatively wide range of its critical process parameters: temperature and interfacial pressure. However, the presence of certain contaminants, such as silicates, oils, and surfactants, are highly detrimental to PE's co-crystallization process.

Fusions that fail due to contamination exhibit smooth, non-ductile separation of the fitting-pipe fusion interface, either in part or in whole. It is important to note, however, that even such areas of non-ductile bonding still have some degree of bonding which can often lead to joints that pass pressure tests (e.g., 150% MAOP) and in some cases even hold operating pressure for years, but such joints are highly sensitive to impact loads and, in cases of saddles, to forces that would cause the joint to “peel” off the pipe.

Because contamination failures are typically difficult to identify in the field, it is of utmost importance that the fusion preparation processes reflect this awareness and that operators adhere to the precautions and best-practices that help minimize fusion contamination.

A note on the general applicability of this work to PE fusion

Although only electrofusion saddle fittings were tested under this scope of work, the conclusions regarding solvent cleaning and the cleaning procedure recommendations provided here are applicable to all PE fusion methods and fitting types. This general applicability is based on the fact that PE's fusion process is the same regardless of the method by which the surfaces to be fused are mated (see **General notes on PE fusion and contamination** above). Additionally, surface contamination affects PE fusion in the same way regardless of the joining method and joint geometry.

Introduction

Recent events have raised concern regarding fusion preparation procedures and more specifically cleaning procedures used by utilities and the protocols used to perform and qualify PE joining procedures. Additionally, recent cases of PE fusion joint failure investigated by GTI have found surface contamination to be the root cause of the failures, despite proper scraping of the pipe.

Field issues related to pipe preparation and PE fusion performance have created a need for better guidelines to assist utilities and their field operators/contractors. Procedures and subsequent training has been enhanced over the years, however, failures still occur even though the procedures and training are followed. Operators are ultimately responsible for ensuring that all PE joining procedures used have been qualified per CFR 192.283, therefore, continuous improvement of joining procedures is vital.

GTI has recognized that in order to properly address joint integrity issues, a comprehensive approach must be taken where the influence of all processes and materials used in creating a joint are acknowledged and understood. To achieve this goal, GTI has begun to develop a process map relating the various elements involved in creating a joint. **Figure 1** shows a portion of this map related to electrofusion joints, which are the primary joint type related to the focus of this project: surface cleaning (highlighted in blue in **Figure 1**).

The work done in this project follows up and complements on the work performed in OTD Project 2.14.e *Guidelines/Best Practices for Scraping PE Pipe and Fittings* (highlighted in green in **Figure 1**). As can be seen in **Figure 1**, these two projects together cover the core pipe surface preparation processes. While OTD Project 2.14.e focused on the scraping and peeling performance of several common scrapers/peelers, this project has focused on the effectiveness of solvent cleaning in removal of surface contaminants.

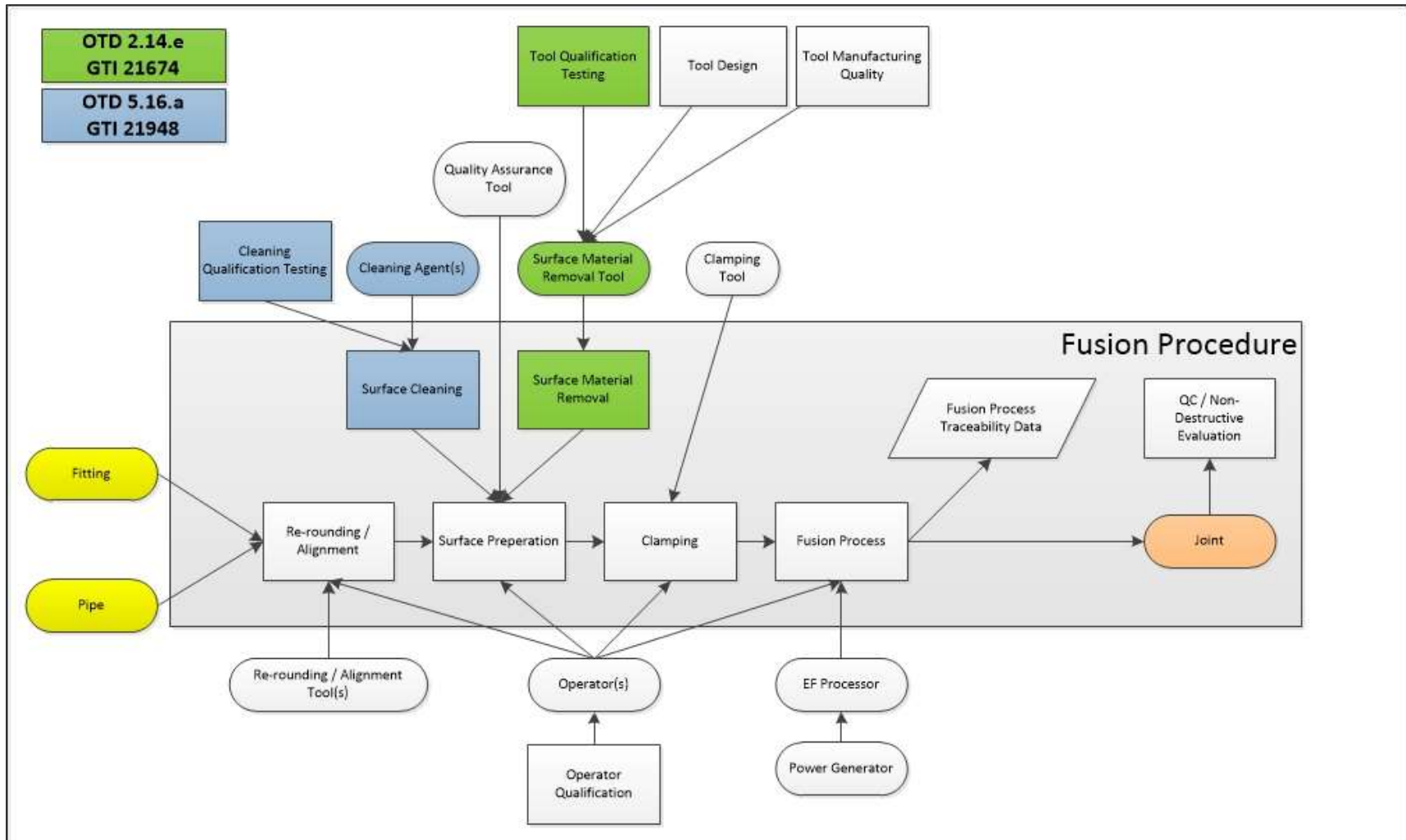

Figure 1. Overview of electrofusion process, with highlights of OTD project scopes

Sponsor Survey

The project sponsors were surveyed with respect to their pipe cleaning procedures. The following tables summarize the survey responses and the general fusion procedure steps as described by each utility's respective operator manuals. The survey helped with the selection of contaminants, cleaning agents, and cleaning tools for testing.

Table 1. Summary of survey responses

	Utility A	Utility B	Utility C
Cleaning agents	Water (optional) 96% IPA wipe, or 99.9% IPA + clean lint-free non-synthetic cloth/paper towel	Damp cotton rag (optional) 91% IPA / 9% DI water + 100% polypropylene non- woven wipe	Water (optional) 96% IPA / 4% DI water + polyester wipe
Clean outside scraping zone	Yes	No	Yes
Cleaning margin outside scraping zone	1 inch	None	Not specified
Soils	Clay, Loam, Rock (bedrock), Brick, Sand and Slurry.	Clay; clay/sand mixture; sand. Backfilling material is sand. Drilling mud is bentonite.	-
Contamination sources	Sweat, hydrocarbons of any kind (motor oil, grease, gasoline, etc.), precipitation from snow and rain.	Oil from bare hands/fingers, ii) oil residue from tracer wire connectors, iii) oil residue from metallic tools.	Dirty scrapers, Leak detection solution, Contaminants from blowing wind
Fusion Procedure Steps			
Step	Utility A	Utility B	Utility C
1	Clean with water	Clean with damp cotton rag	Clean with water
2	Clean with IPA	Clean with IPA	Clean with IPA
3	Mark	Mark	Mark
4	Scrape	Scrape	Scrape
5	Clean with IPA	Clean with IPA	Optional Clean with IPA
6	Fuse	Fuse	Fuse

Table 1. Summary of survey responses – continued

	Utility D	Utility E
Cleaning agents	Water, 99.8% IPA	100% cotton rag, 91% IPA / 9% DI water 100% polypropylene non-woven wipe 99.5% acetone / DI water with non-woven pulp polyester-blend towelette
Clean outside scraping zone	Yes	Yes
Cleaning margin outside scraping zone	Not specified	25% of fitting length for couplings, 1 inch for heat fusion saddles
Soils	Native soil if not rocky, bed in sand if soil contains rocks larger than 1". No crushed rock over 1/8". Drilling mud is not specified.	Native: Silts and Loams, Sandy and Gravel. Imported: Sand. HDD: Bentonite.
Contamination sources	Body oils (if required gloves are not worn), grease, oil residue	Trenchless installations: PE pipe exposed to sewer elements from cross bore. PE pipe exposed to heavy hydrocarbon contaminated soil.
Fusion Procedure Steps		
Step	Utility D	Utility E
1	Clean with water	Clean with water
2	Clean with IPA	Clean with acetone or IPA
3	Mark	Mark
4	Scrape	Scrape
5	Optional Clean with IPA	Optional Clean with acetone or IPA
6	Fuse	Fuse

Testing

The focus of this project was to test the performance of commonly used solvents and cleaning tools in terms of removal of contamination (bentonite powder, silicone grease, and talc powder). Based on the sponsor survey and additional interaction with the project sponsors, a test matrix was developed that was comprised of 120 test runs. The test matrix covered all combinations of the contaminants, cleaning agents, and cleaning tools listed in **Table 2**. Each combination was tested four times – twice on MDPE pipe and twice on HDPE pipe.

Table 2. List of tested contaminants, cleaning agents, and cleaning tools

Contaminant	Cleaning Agent	Cleaning Tool
Talc	99% Isopropyl alcohol	Lint-free wipe
Bentonite	91% Isopropyl alcohol	Cotton cloth rag
Silicone grease	Acetone	Paper towel

Talc powder was selected because of its historic use in the UK water industry, as specified in the standard *WIS-32-4-08 Specification for the Fusion Jointing of Polyethylene Pressure Pipeline Systems Using PE80 and PE100 Materials*. In the work conducted by the UK water industry, talc was chosen as a proxy for surface contamination encountered in the field.

Bentonite powder was selected because it is the primary mineral in drilling fluids used in horizontal directional drilling (HDD) and, being a silicate, it has a similar detrimental effect as other soils or dust.

Silicone grease (Dow Corning Molykote High Vacuum Grease) was selected for testing given its high viscosity and insolubility in water, alcohols, and acetone, which leads to difficulty in its removal. Applications of silicone grease include O-ring seals, mechanical stab coupling, and tracer wire couplings.

The 99% isopropyl alcohol was PTI Process Chemicals Isopropanol (Isopropyl Alcohol 99%), Technical Grade UN-1219, Item # R-615-1, CAS # 67-63-0.

The 91% isopropyl alcohol was obtained from mixing the above 99% isopropyl alcohol with distilled water (at GTI).

The acetone was Sunnyside Acetone (100%), CAS # 67-64-1.

Pipe Contamination Apparatus

A pipe contamination apparatus was constructed in order to contaminate pipe in a consistent manner with a fine powder (talc, bentonite). The apparatus was built to meet the specifications given in the UK standard *WIS-32-4-08 Specification for the Fusion Jointing of Polyethylene Pressure Pipeline Systems Using PE80 and PE100 Materials*. The details of this device are given in **Appendix A – Pipe Contamination Apparatus**.

Preliminary Contamination Removal Testing

Preliminary cleaning tests were performed on rings cut from 2” IPS HDPE pipe to get a sense of how effective each cleaning agent and tool combination was at removing a given contaminant. Once the rings were cut, they were contaminated, cleaned, and tested by FTIR-ATR according to the following protocol:

1. Contaminate pipe ring’s OD,
2. Wet the tool with the solvent,
3. Make one wiping pass around circumference of the ring,
4. Perform FTIR-ATR test.

The following figures show the post-cleaning results for each contaminant/solvent combination. Each figure contains the FTIR spectrum for virgin PE, contaminated PE, and post-cleaning results using three different cleaning tools: lint-free wipe, cotton rag, and paper towel. Specifically, the tools were:

- Lint-free wipe: Sontara EC Engineered Cloth Wipers - PR831
- Cotton rag: Intex Supply Exact Cuts rags
- Paper towel: Kimberly-Clark Scott Towels

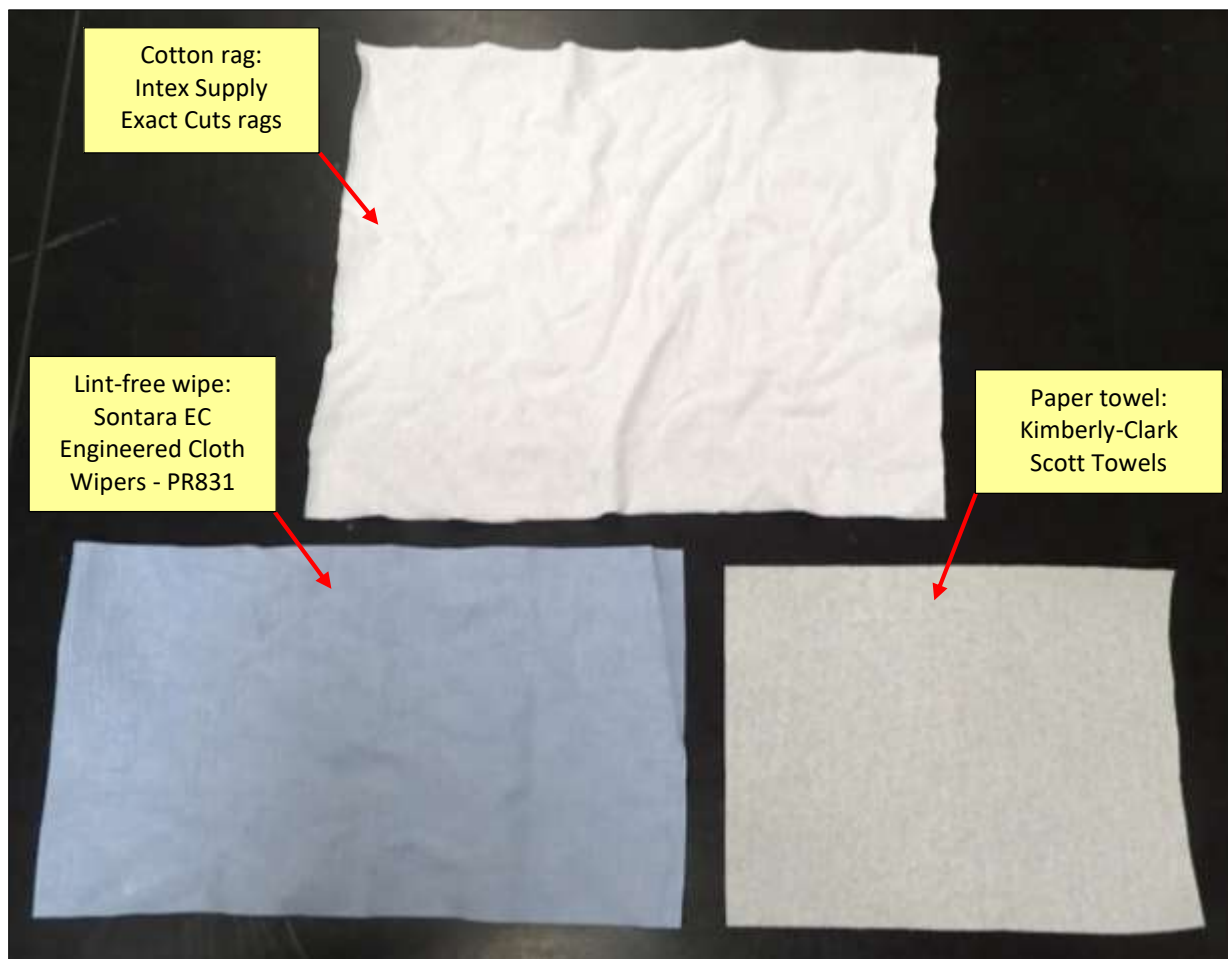

Figure 2. Tested cleaning tools

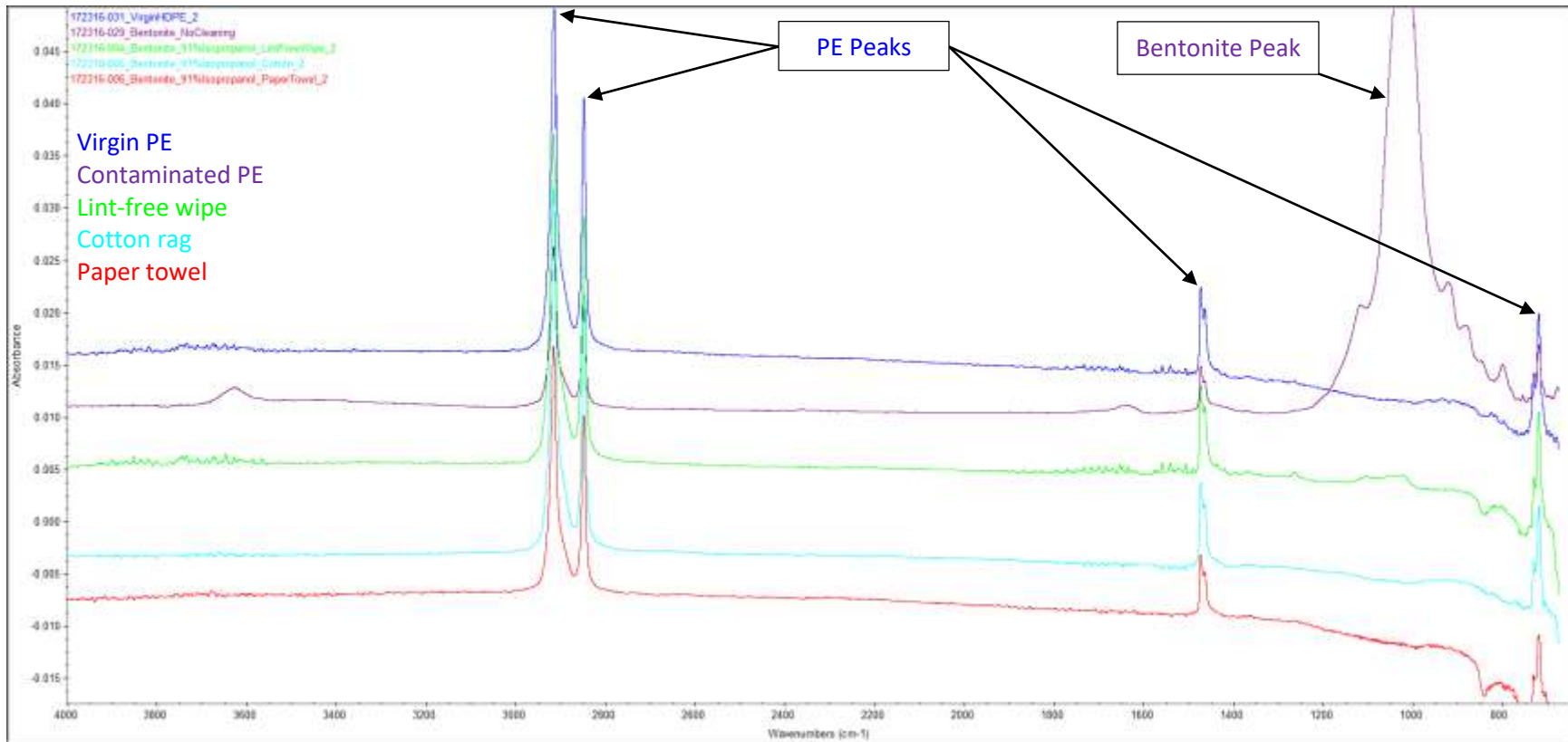

Figure 3. Post-cleaning FTIR spectra, contaminant=bentonite, solvent=91% isopropyl alcohol/9% distilled water

Figure 3 shows that 91% isopropyl alcohol was effective at removing bentonite with all tools. This is seen by the absence of a bentonite peak in the spectra of the samples that were cleaned.

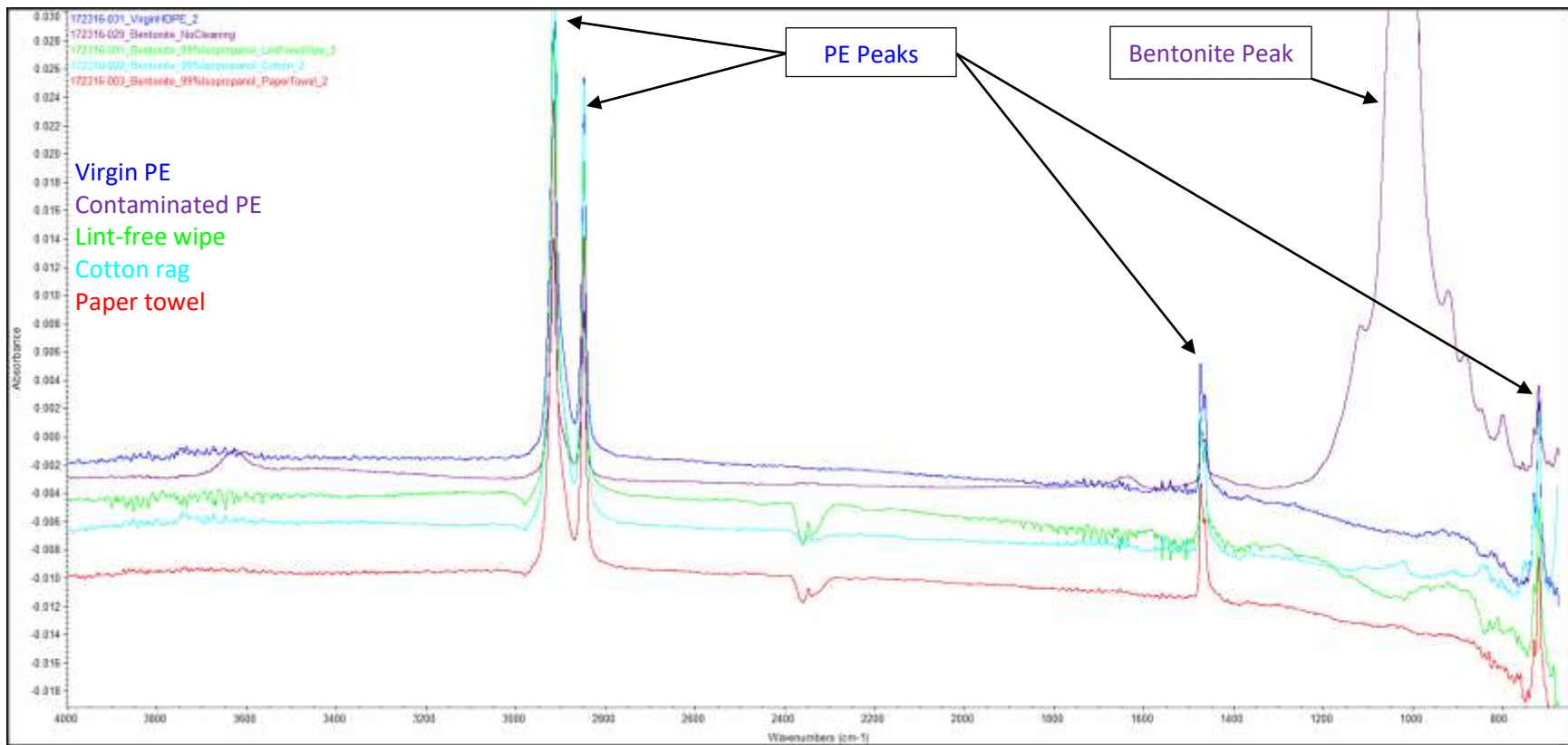

Figure 4. Post-cleaning FTIR spectra, contaminant=bentonite, solvent=99% isopropyl alcohol/1% distilled water

Figure 4 shows that 99% isopropyl alcohol was effective at removing bentonite with all tools.

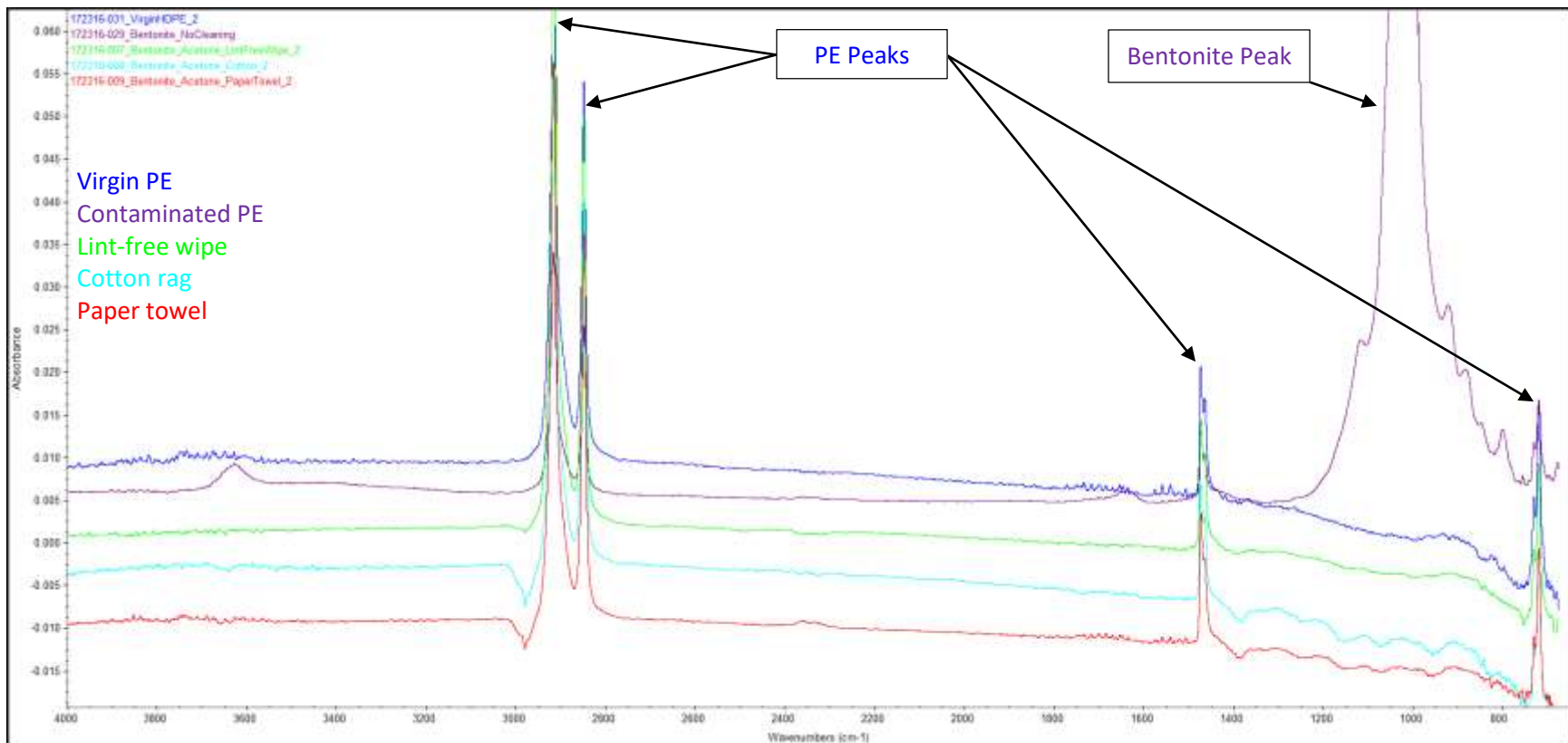

Figure 5. Post-cleaning FTIR spectra, contaminant=bentonite, solvent=acetone

Figure 5 shows that acetone was effective at removing bentonite with all tools.

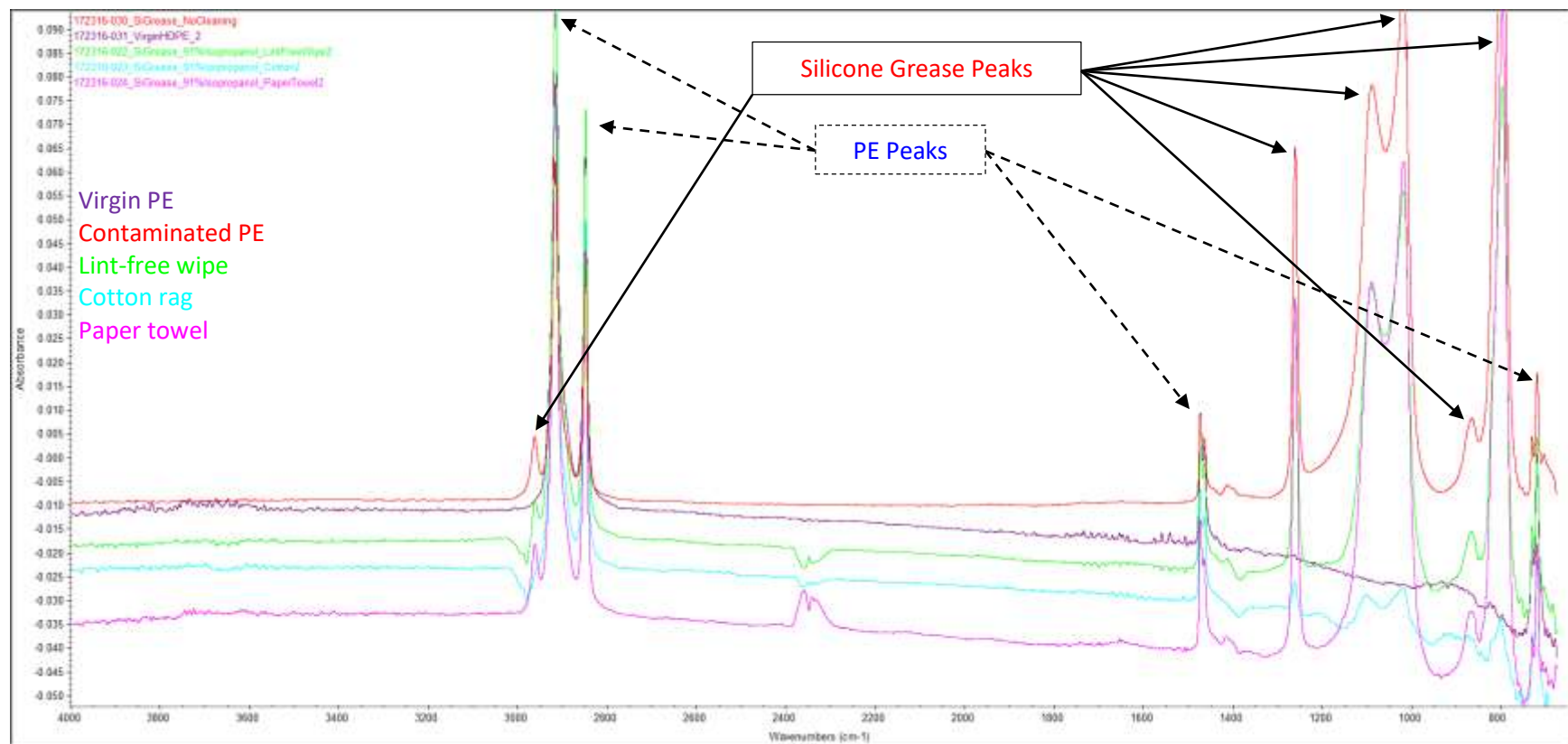

Figure 6. Post-cleaning FTIR spectra, contaminant=silicone grease, solvent=91% isopropyl alcohol/9% distilled water

Figure 6 shows that 91% isopropyl alcohol was not effective at removing silicone grease when used with a lint free wipe or paper towel. The cotton rag was much better than the other tools, but did not completely remove the silicone grease.

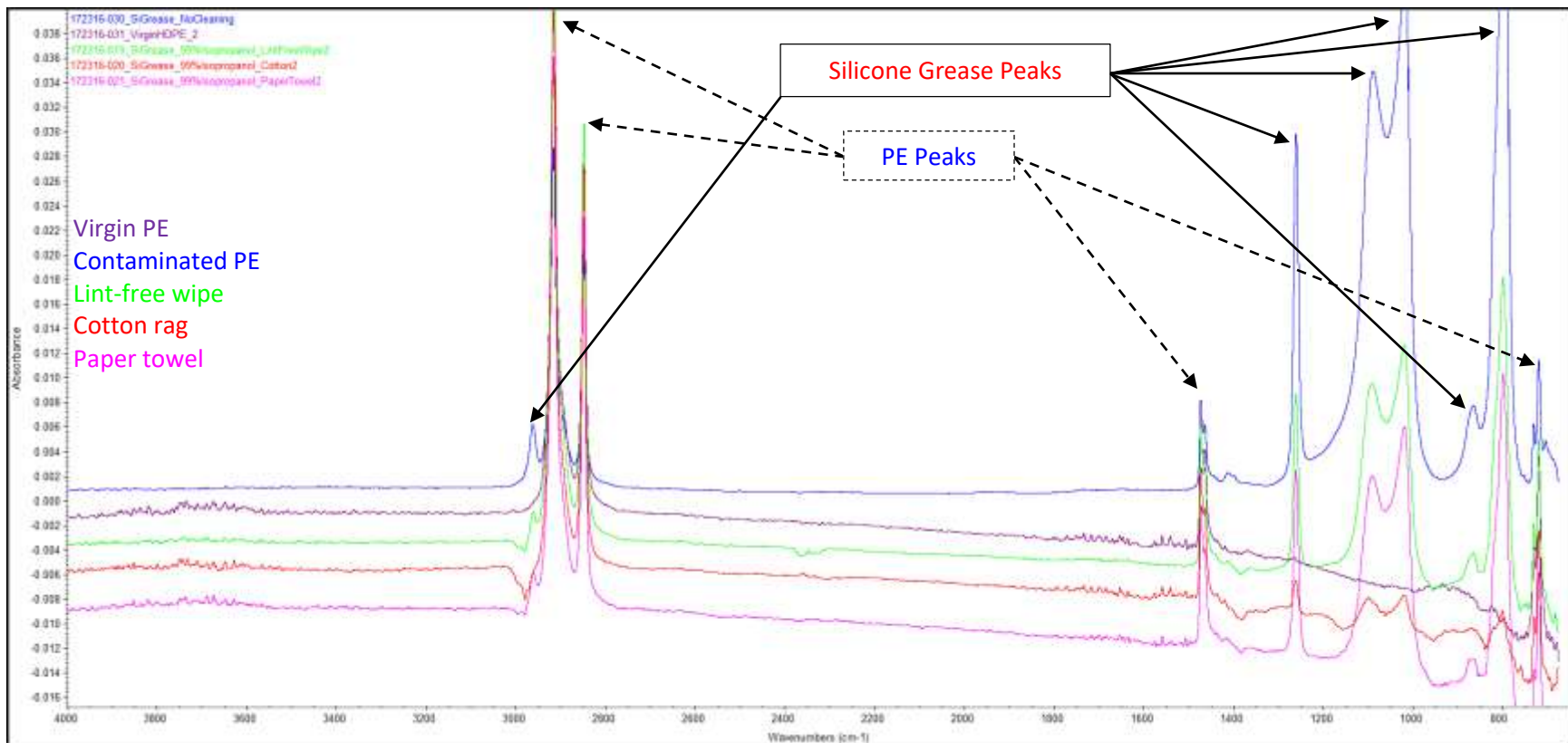

Figure 7. Post-cleaning FTIR spectra, contaminant=silicone grease, solvent=99% isopropyl alcohol/1% distilled water

Figure 7 shows that 99% isopropyl alcohol was not effective at removing silicone grease when used with a lint free wipe or paper towel. The cotton rag was much better than the other tools, but did not completely remove the silicone grease.

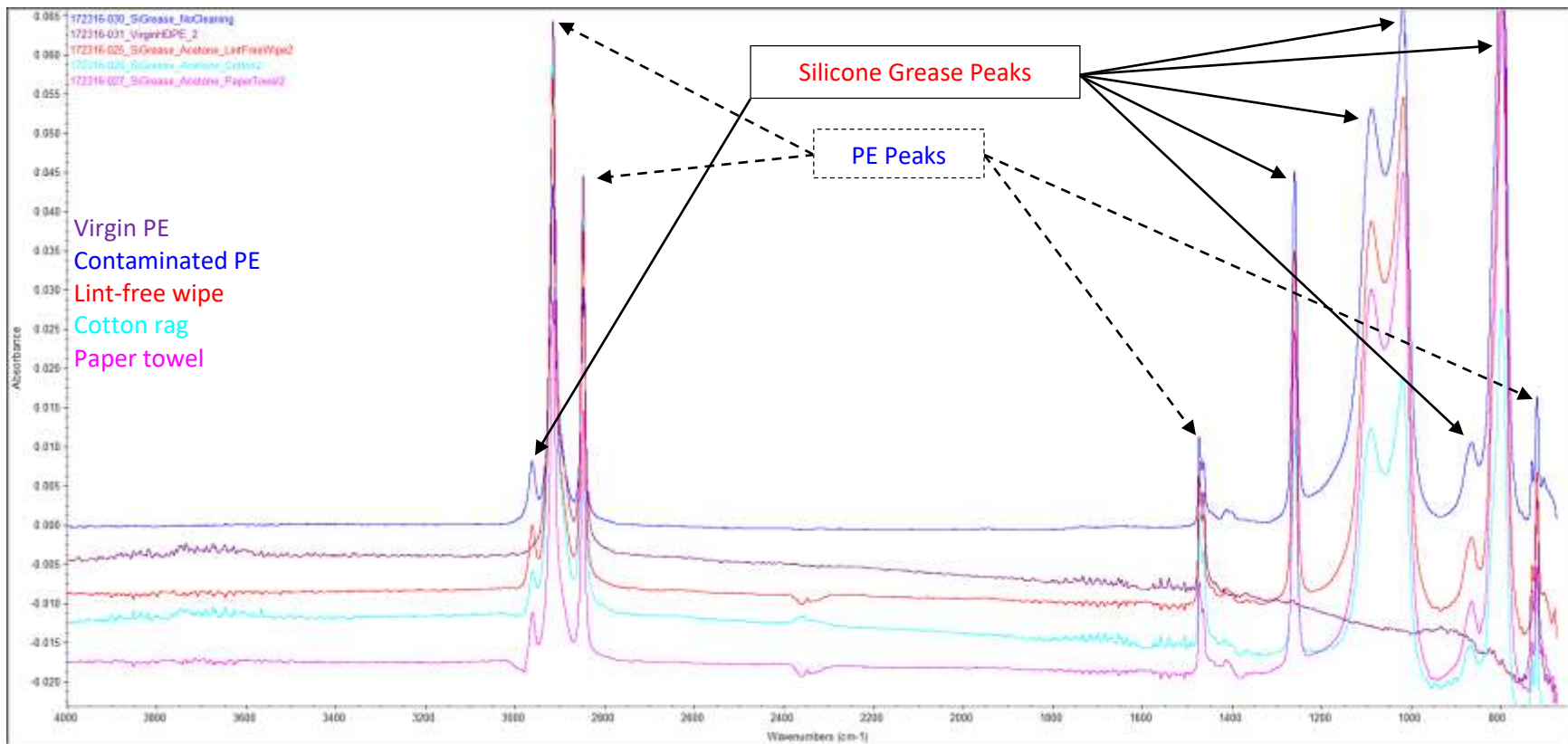

Figure 8. Post-cleaning FTIR spectra, contaminant=silicone grease, solvent=acetone

Figure 8 shows that acetone was not effective at removing silicone grease with any of the tools.

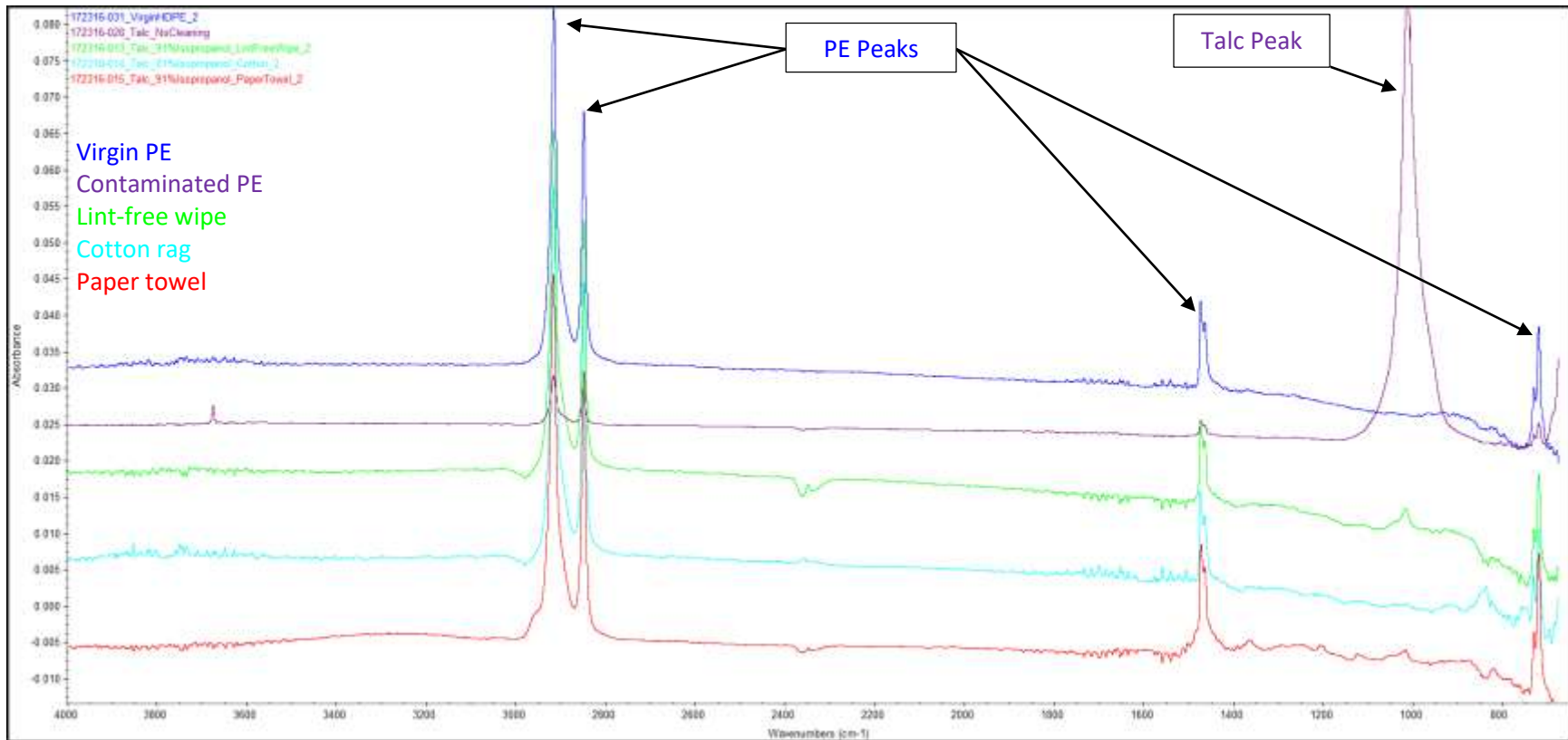

Figure 9. Post-cleaning FTIR spectra, contaminant=talc, solvent=91% isopropyl alcohol/9% distilled water

Figure 9 shows that 91% isopropyl alcohol was effective at removing most of the talc with the lint-free wipe and paper towel, but did not completely remove the talc. With the cotton rag, the talc peak was completely removed.

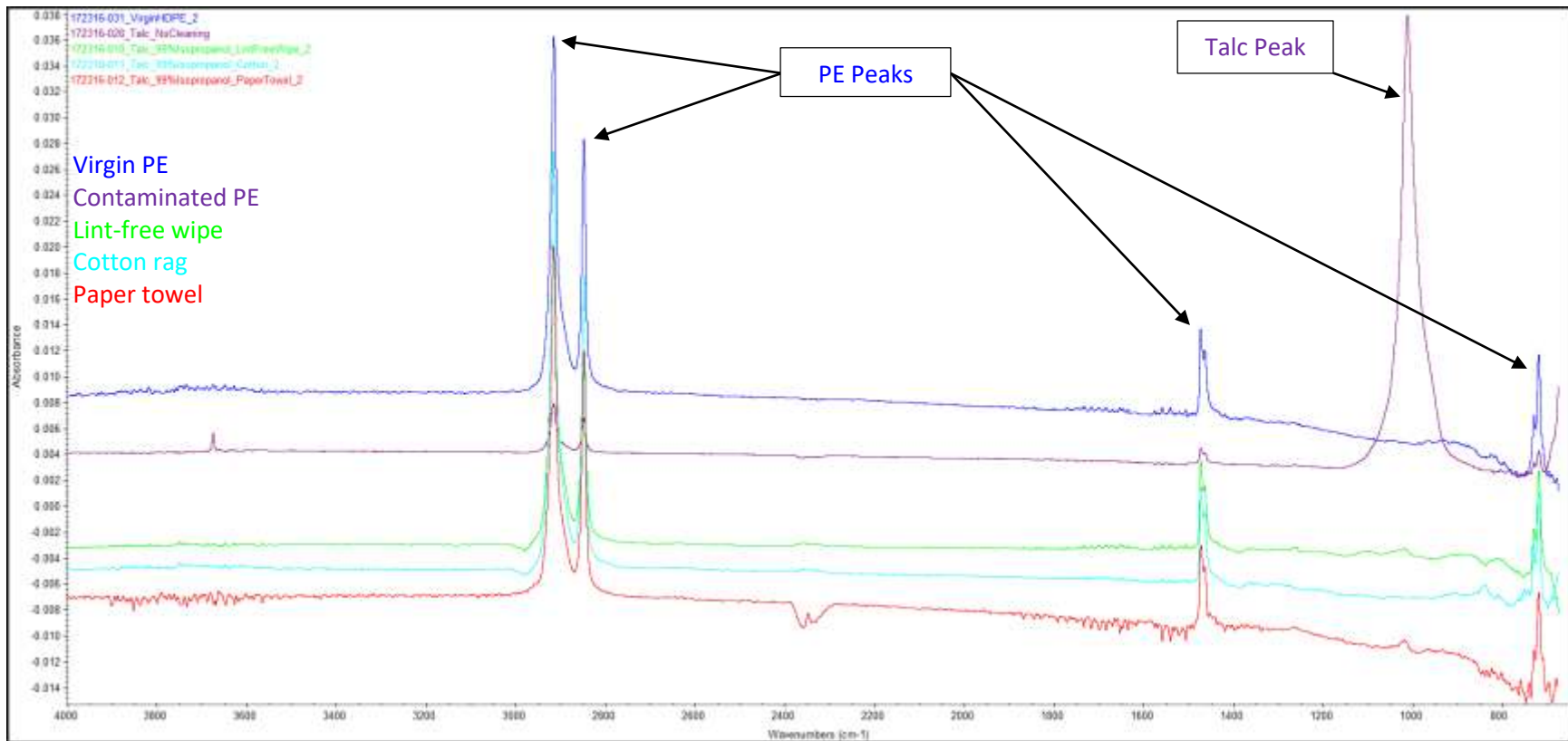

Figure 10. Post-cleaning FTIR spectra, contaminant=talc, solvent=99% isopropyl alcohol/1% distilled water

Figure 10 shows that 99% isopropyl alcohol was effective at removing most of the talc with the lint-free wipe and paper towel, but did not completely remove the talc. With the cotton rag, the talc peak was completely removed.

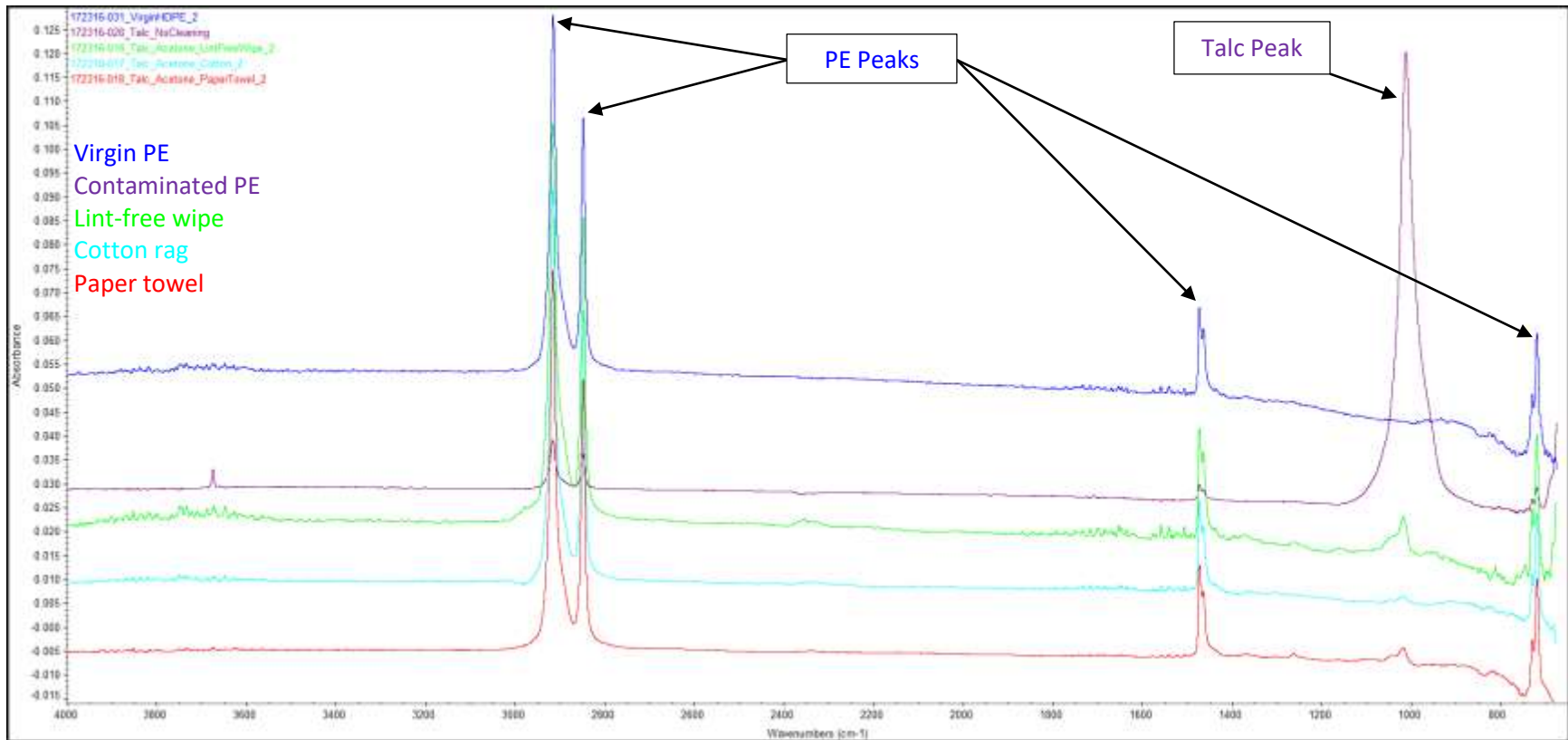

Figure 11. Post-cleaning FTIR spectra, contaminant=talc, solvent=acetone

Figure 11 shows that acetone was effective at removing most of the talc with all tools, but did not completely remove the talc.

Contamination Removal and Electrofusion Testing

Contamination removal tests were performed using a 2" IPS electrofusion saddle fittings. This joint type was selected based on its commonality in the field and the ability to easily perform a (saddle) decohesion tests, which gives a good qualitative and quantitative result of the ductility of the fusion over the entire fusion zone.

The test protocol was as follows:

1. Scrape the pipe (using OEM 'Peeler', see **Figure 12**),
2. Contaminate the pipe,
3. Wet the tool with the solvent,
4. Make one wiping pass along pipe axis, starting at one end of the scraped zone and moving to its other end, with the wipe fully encircling the pipe (2" IPS),
5. If contaminant was still visible on the fusion zone, repeat Step 3 and Step 4 with a new tool,
6. Wait for pipe to dry,
7. Assemble electrofusion saddle (as soon as pipe is dry) and perform fusion.

Based on the procedure above, the majority of the test runs with talc and bentonite required only one cleaning pass, while the majority of runs with silicon grease required two passes.



Figure 12. OEM 'Peeler', 2" IPS

Following the scraping procedure, electrofusion saddles were fused and then peeled off using the ISO 13956 Type A2 decohesion test method (see **Figure 13** and **Figure 14**).

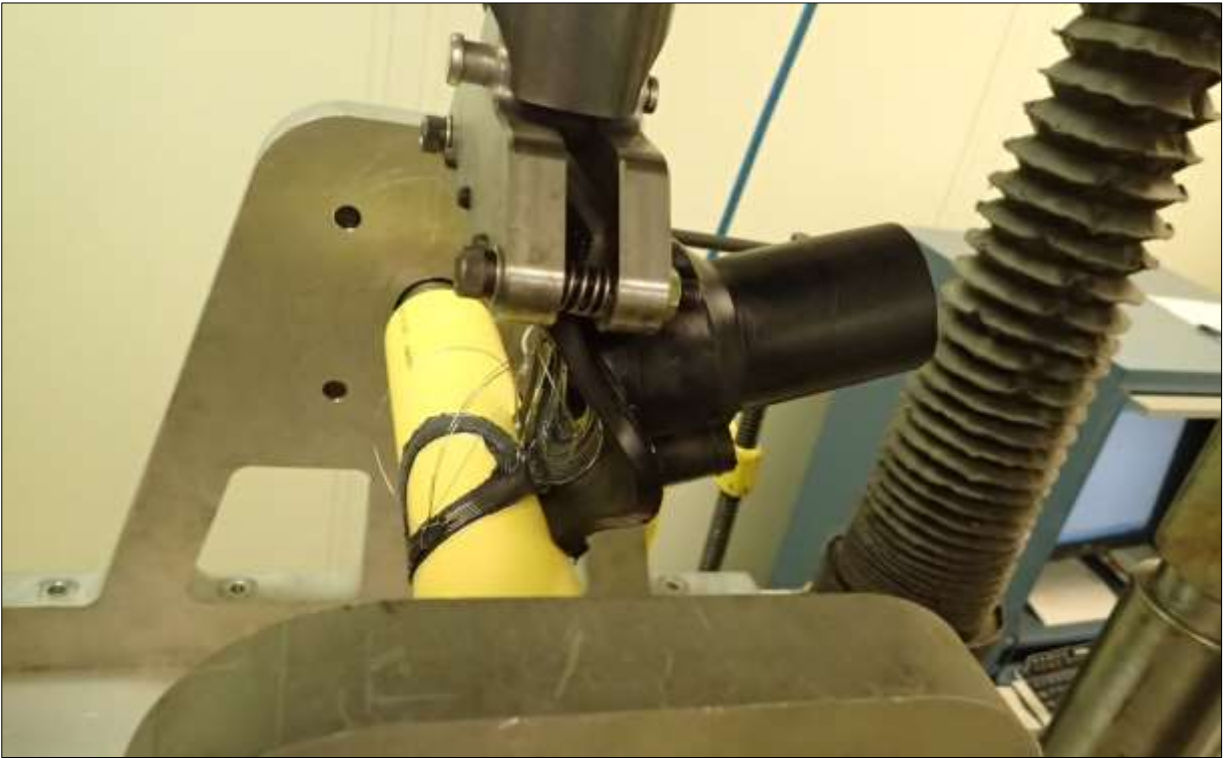

Figure 13. Example of saddle decohesion test

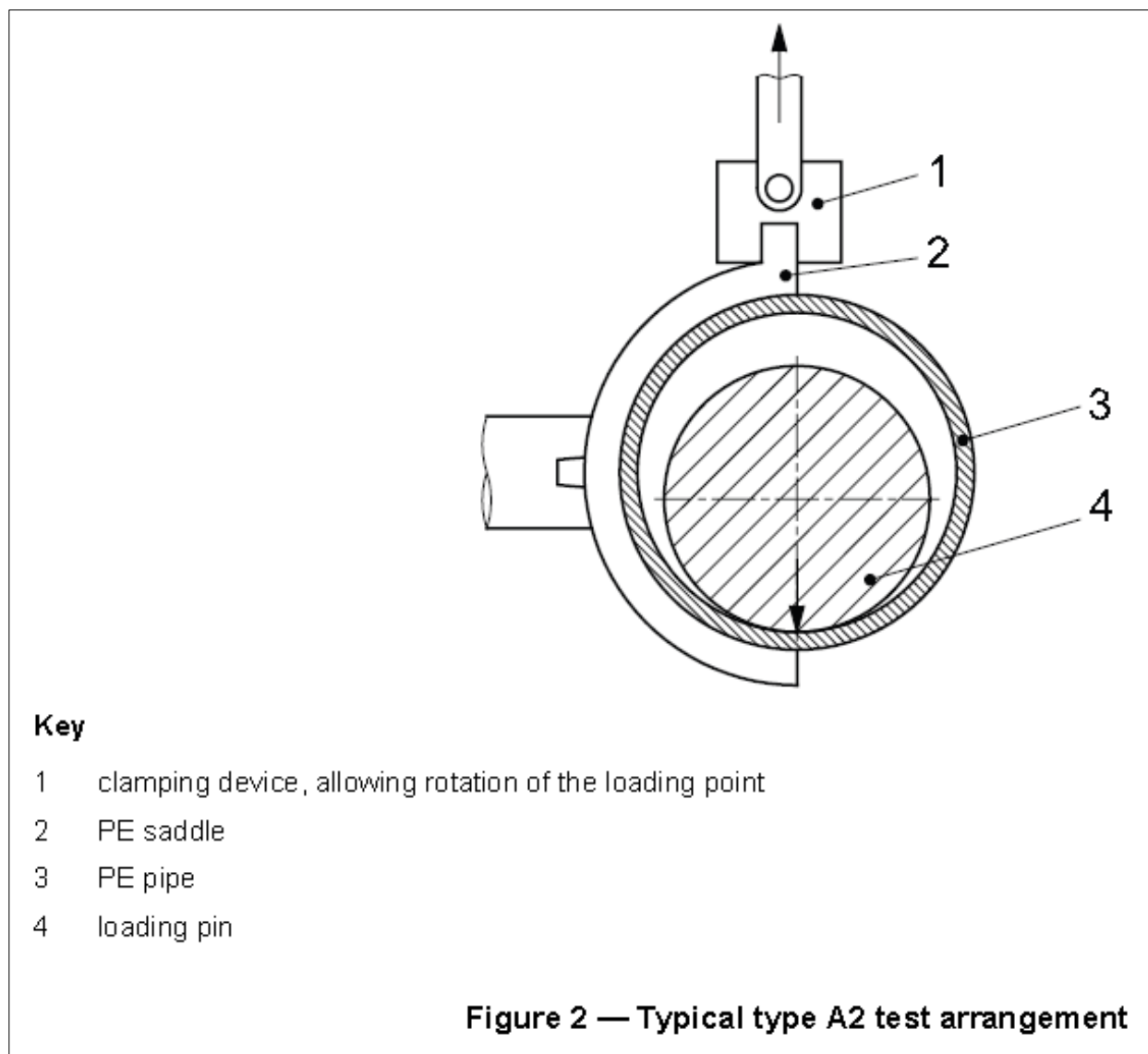

Figure 14. Schematic of ISO 13956 type A2 decohesion test arrangement

Fusions were scored based on the percent of the fusion zone that exhibited ductile separation¹. The scores were binned in 20% intervals: 0-20%, 21-40%, 41-60%, 61-80%, and 81-100%. Higher ductility scores indicate better removal of the contaminant. For general reference, **Figure 15** shows some examples of results at three different ductility bins.



Figure 15. Examples of saddle decohesion test results with their ductility bin score

Figure 16 through **Figure 18** show combined results from the 120-run test matrix. The combined results charts help show general trends per contaminant, agent, and tool. **Figure 19** through **Figure 21** show the detailed results, broken down by the specific contaminant-agent-tool combination.

¹ Since the objective of this test was to assess removal of contamination, fusion voids were disregarded in the scoring.

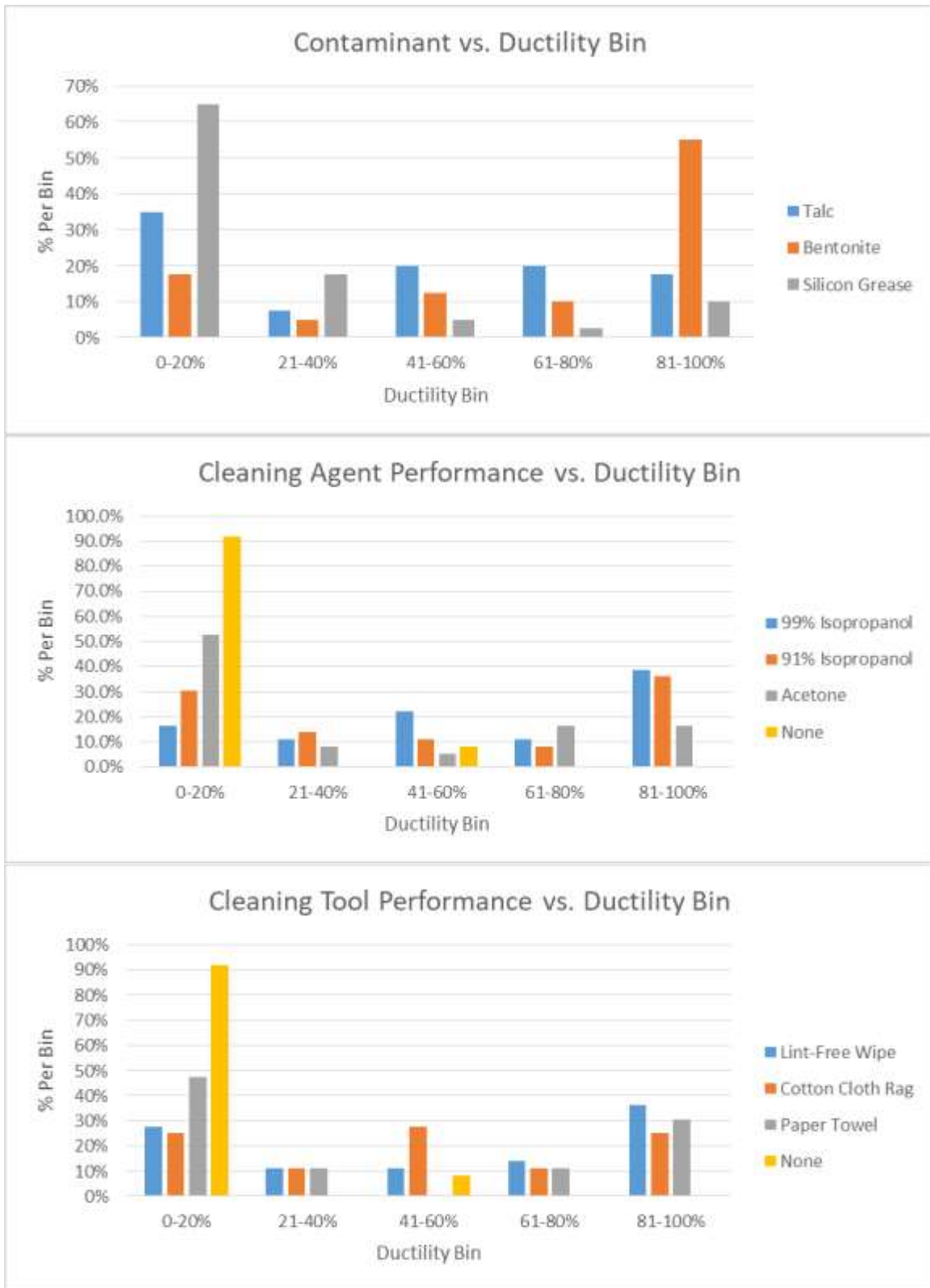

Figure 16. Combined decohesion test results

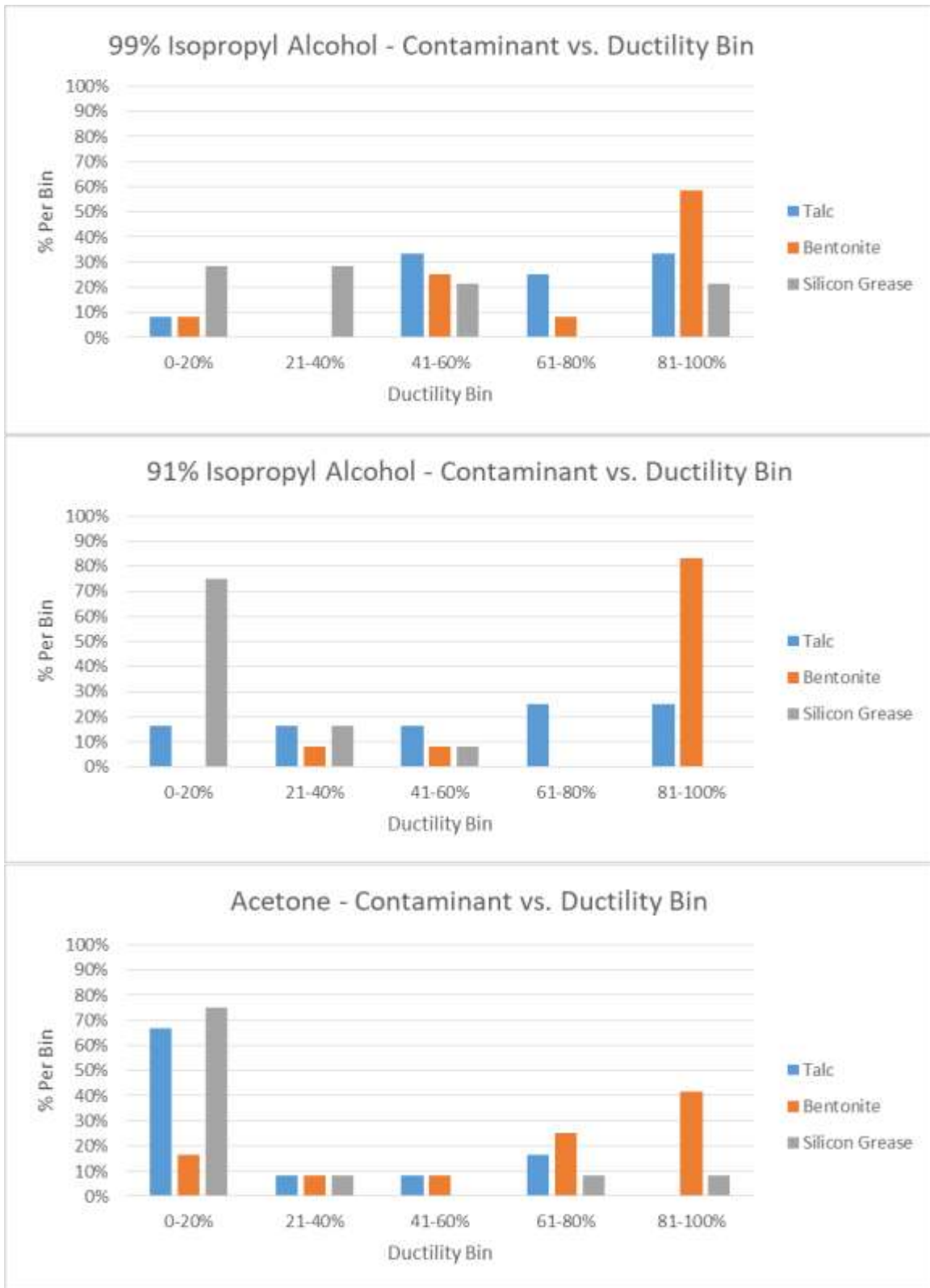

Figure 17. Cleaning agent performance with different contaminants



Figure 18. Cleaning tool performance with different contaminants

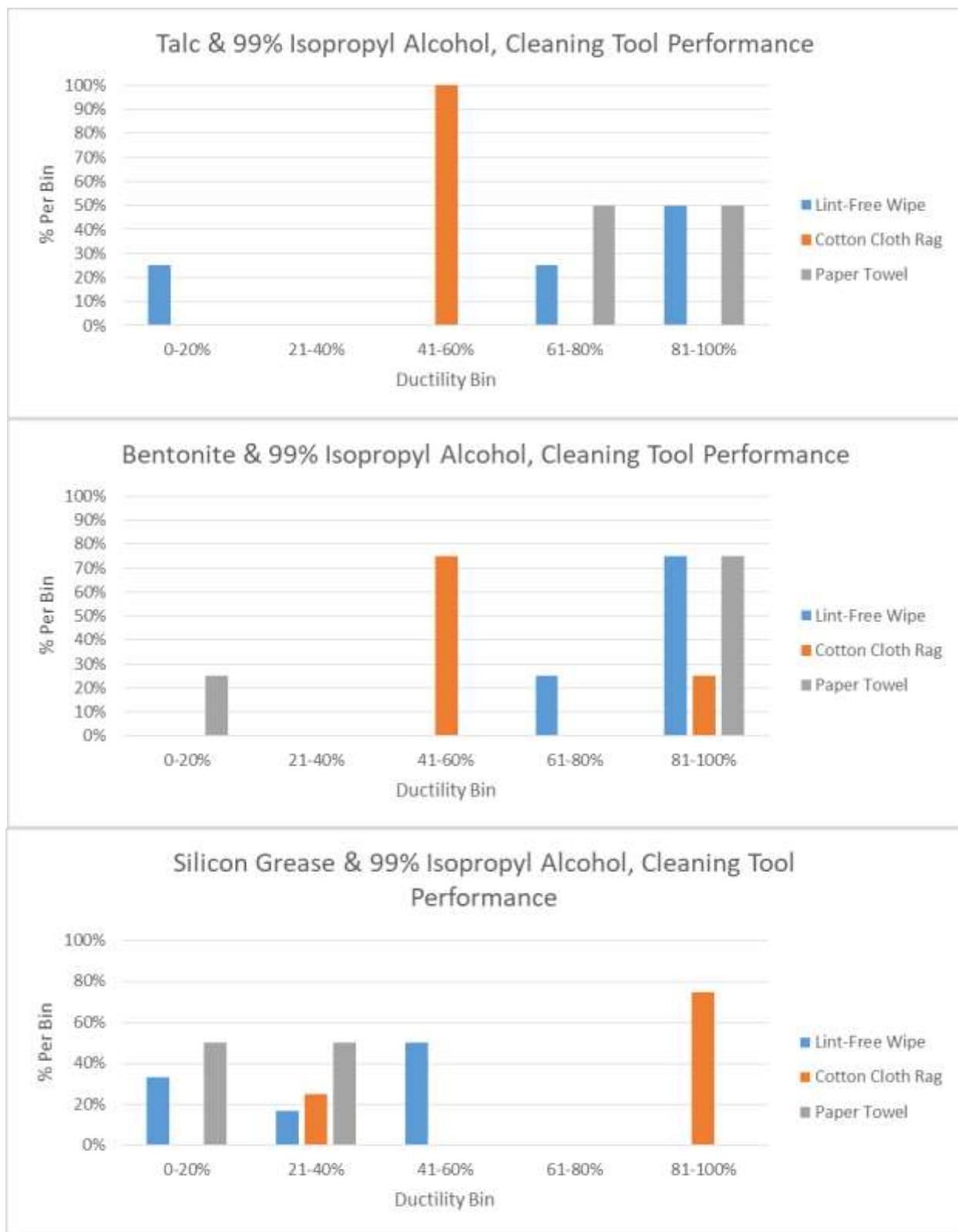

Figure 19. Detailed results, 99% isopropyl alcohol

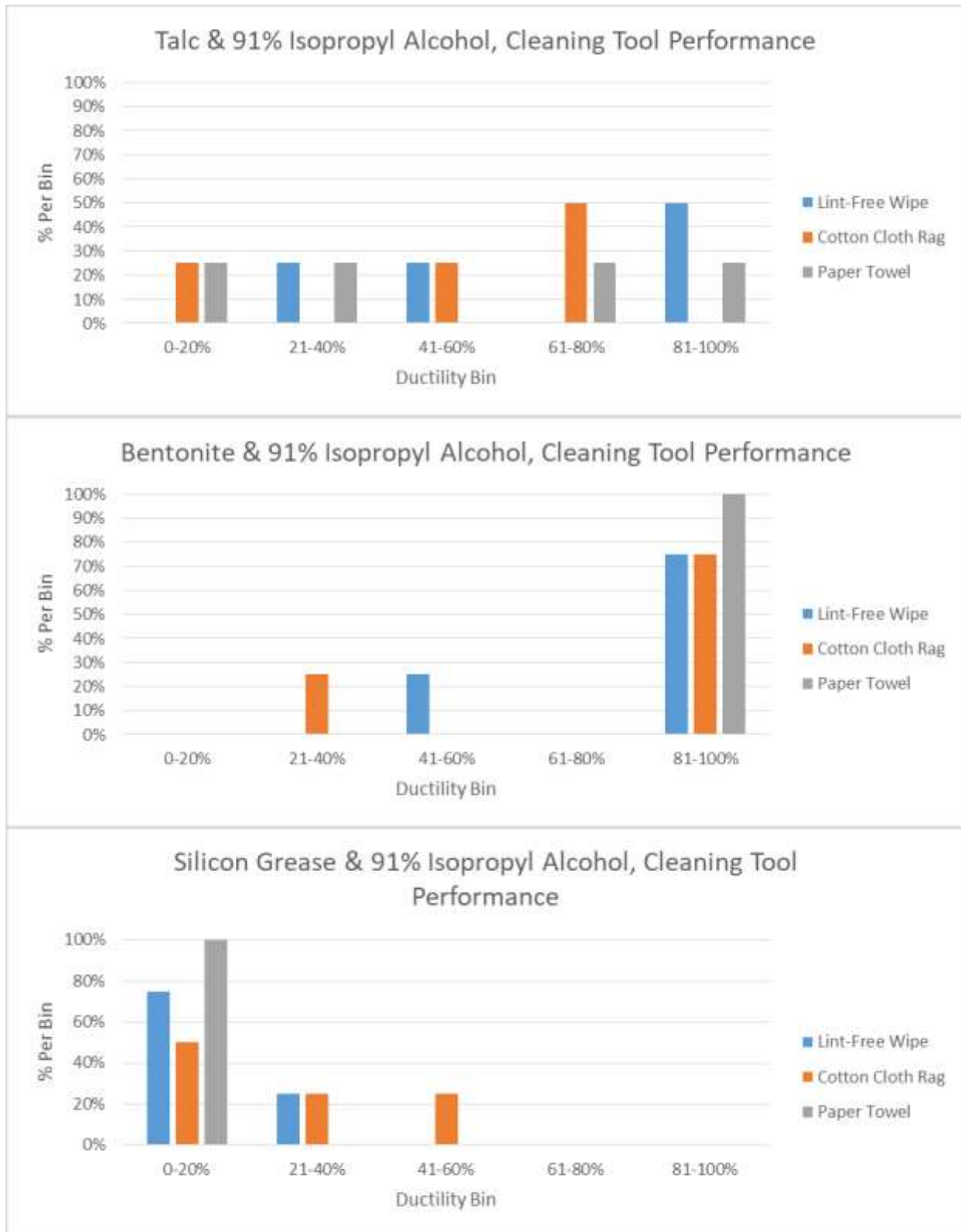

Figure 20. Detailed results, 91% isopropyl alcohol

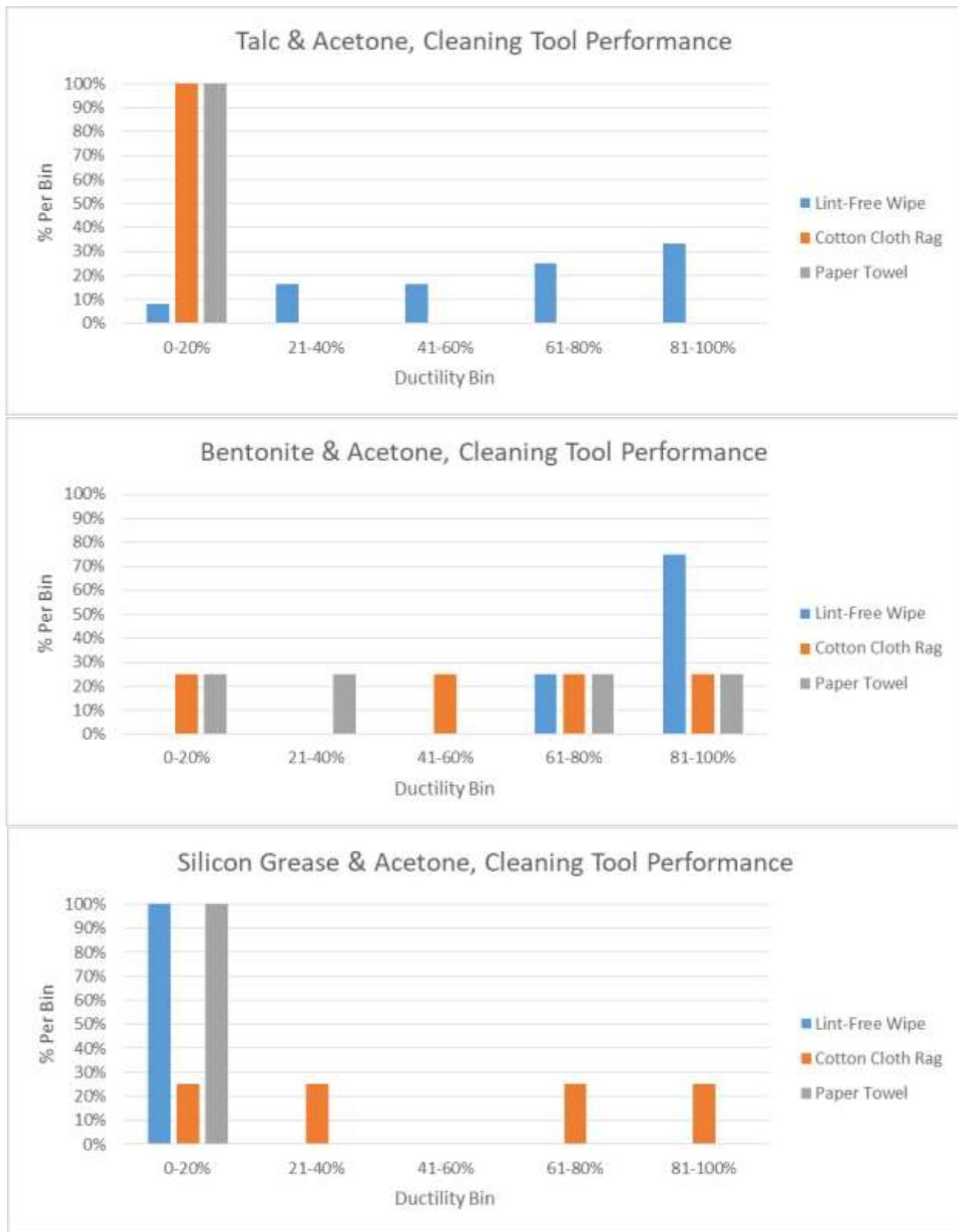

Figure 21. Detailed results, acetone

Discussion and Conclusions

The testing results have led to the following observations:

- The preliminary contamination removal tests on non-scraped pipe rings indicated that solvent cleaning is fundamentally effective at removing talc and bentonite powders on a relatively small and smooth surface.
- Silicone grease is particularly difficult to remove regardless of solvent and cleaning tool combination.
- The contamination removal/fusion tests indicate that in pipe cleaning scenarios any given wiping pass will not uniformly remove surface contamination.
 - The variability in cleaning is due to OD surface roughness, non-uniform wiping contact, physical variability of the cleaning tool, and contaminant distribution on the surface.
- Solvent cleaning will remove loose contamination such that the pipe will look clean.
- The pipe cleaning protocol employed in this project produced highly variable decohesion test results, and no 100% ductile joints.

The above observations lead to the following conclusions and recommendations:

- Solvent cleaning should be used to remove loose dirt and the bulk of surface contaminants before scraping.
 - This is further supported by the scraping-only test results from OTD Project 2.14.e *Guidelines/Best Practices for Scraping PE Pipe and Fittings*, shown in **Figure 22**.
- More than a single wiping pass should be required due to the variability in contamination removal of any single pass.
 - Each subsequent wiping pass should be within the area of the preceding wiping pass to avoid reintroduction of contamination from outside of the first wiping pass area.
- Any wiping pass should be made with a new cleaning tool to avoid reintroduction of contamination from a used cleaning tool.
- Any wiping pass should be made in the same single direction to avoid or minimize spreading of contamination that does not get removed by the current or previous pass.

Based on the inconsistency in solvent-cleaning's contamination removal, as observed in this project's testing, it is not clear if post-scraping solvent cleaning will be sufficiently effective at removing contaminants introduced after scraping. Additional testing is required to resolve the acceptability of post-scraping solvent cleaning – specifically, multiple wiping passes, water washing, and degree of contamination need to be evaluated.

Figure 22 shows a comparison of the overall decohesion test results from pipes contaminated with bentonite. This comparison provides an illustration of the general contribution of solvent cleaning and scraping, where joints fused with no cleaning or scraping consistently fall in the 0-20% ductility bin (as expected), joint fused with solvent cleaning alone fall in all ductility bins, and joints fused with only scraping predominantly fall in the top two ductility bins. This suggests that both solvent cleaning and scraping must be used to consistently achieve 100% ductility by using the solvent cleaning to remove loose dirt and then scraping to remove the outer layer of the pipe together with any contaminant that may be adhering to or embedded in it.

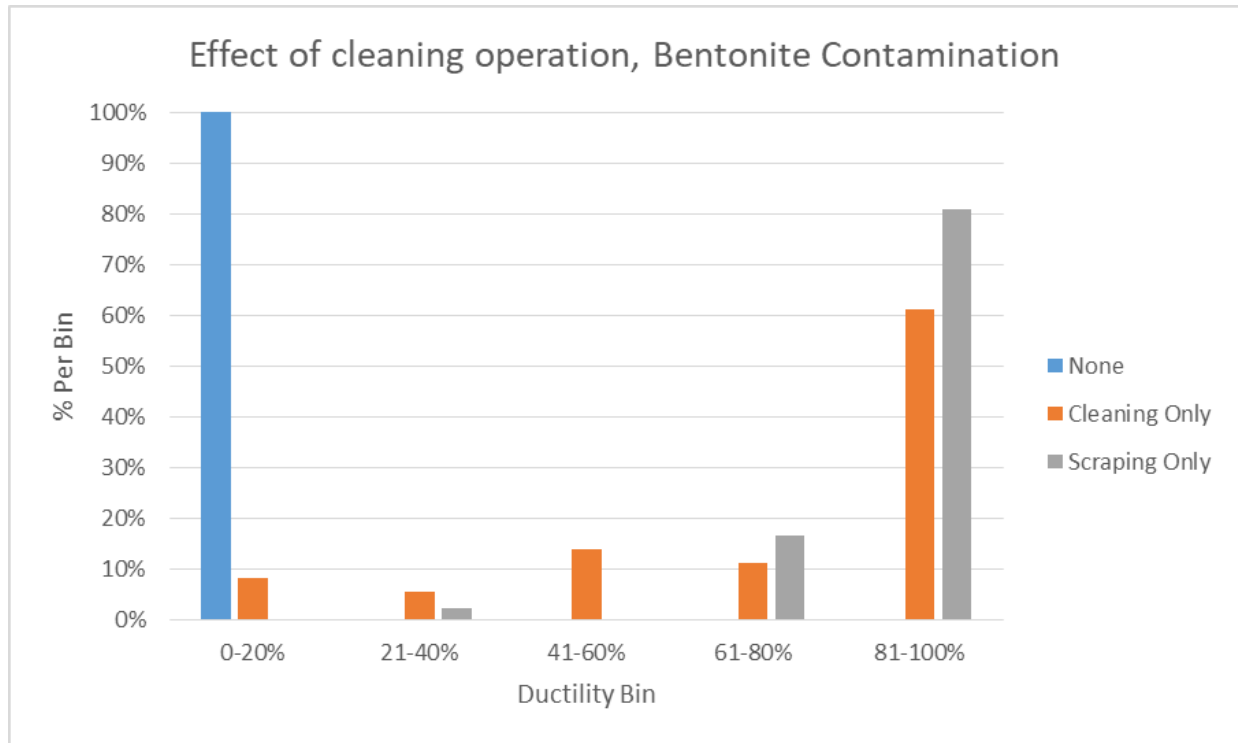

Figure 22. Comparison of cleaning operations with bentonite contamination, overall decohesion results

The findings in this project and OTD Project 2.14.e *Guidelines/Best Practices for Scraping PE Pipe and Fittings* lead to the suggestion of a preparation technique where the pipe is thoroughly washed and cleaned prior to scraping and where the time between scraping and assembling of the fitting is minimized. A proposed technique, which was also included in the final report of OTD Project 2.14.e, is detailed later in this section.

Overall, the various test results of this project and the results from OTD Project 2.14.e lend support to the observation that to achieve successful PE fusions best practices should be adopted in conjunction with thorough operator training with specific attention to prevention of contamination of the fusion areas of the pipe and fitting. The following are aspects that should be taken into account in operator training and reflected in operating procedures.

Avoiding contamination of the fusion zone

- Water wash any bulk and loose dirt and dust on the pipe prior to scraping.
 - The cleaned area should exceed the area to be scraped.
- Solvent-clean the assembly area immediately prior to scraping of the pipe.
 - The solvent cleaned area should be within the area cleaned with water.
 - Fitting's fusion zone should also be solvent-cleaned immediately before assembly onto the pipe.
 - Allow solvent to fully dry before assembly.
- Minimize time between cleaning, scraping, assembling and fusing.
- Be aware that the scraping tool should be clean of contaminants before each use.
- Be aware that the scraping tool should be in proper working condition.
- Be aware that shavings from the scraping operation may wipe against a scraped surface, and thus may transfer contaminants onto it, if contaminants are present prior to scraping.
- Be aware that dirt, mud, water, and dust can resettle on the pipe during and after scraping due to one or a combination of:
 - Wind
 - Rain
 - Operator motion
 - Static charge on the pipe
- If the joining procedure must be delayed, apply stretch wrap to minimize contamination of the cleaned area.
- Smooth scraper blades may be preferable to serrated blades,
 - Serrated blades leave a rough surface that is harder to clean than a smooth surface.
 - Serrated blades are less consistent in terms of scrape depth and are more likely to leave portions of shallow scraping (ridges).

General notes on PE fusion and contamination

PE fusion is a stochastic process where two molten interfaces are brought into contact such that upon cooling and solidification the interfaces co-crystallize to form a ductile welded area. This fusion process is normally robust within a relatively wide range of its critical process parameters: temperature and interfacial pressure. However, the presence of certain contaminants, such as silicates, oils, and surfactants, are highly detrimental to PE's co-crystallization process.

Fusions that fail due to contamination exhibit smooth, non-ductile separation of the fitting-pipe fusion interface, either in part or in whole. It is important to note, however, that even such areas of non-ductile bonding still have some degree of bonding which can often lead to joints that pass pressure tests (e.g., 150% MAOP) and in some cases even hold operating pressure for years, but such joints are highly sensitive to impact loads and, in cases of saddles, to forces that would cause the joint to "peel" off the pipe.

Because contamination failures are typically difficult to identify in the field, it is of utmost importance that the fusion preparation processes reflect this awareness and that operators adhere to the precautions and best-practices that help minimize fusion contamination.

A note on the general applicability of this work to PE fusion

Although only electrofusion saddle fittings were tested under this scope of work, the conclusions regarding solvent cleaning and the cleaning procedure recommendations provided here are applicable to all PE fusion methods and fitting types. This general applicability is based on the fact that PE's fusion process is the same regardless of the method by which the surfaces to be fused are mated (see **General notes on PE fusion and contamination** above). Additionally, surface contamination affects PE fusion in the same way regardless of the joining method and joint geometry.

Suggested Scraping Procedure Guideline

Figure 23 shows a top-level generic scraping procedure guideline incorporating the lessons learned during this project, addressing contamination prevention in particular. The rationale behind this procedure is that all contamination will be removed prior to scraping and then minimizing the chances of the scraped pipe getting contaminated. The critical contamination avoidance aspects of the proposed procedure are (in chronological order):

5. Water-wash of pipe (exceeding the area to be scraped).
6. Solvent cleaning of the pipe with a specific wiping technique (exceeding area to be scraped, but within the water-washed area).
7. Scraping of the pipe **immediately after** solvent cleaning (within the solvent-cleaned area).
8. Assembly of the fitting and performing the fusion **immediately after scraping**.

Figure 24 and **Figure 25** show schematics of the cleaned areas for saddle and coupling fittings, respectively.

For situations where a fitting cannot be fused immediately after scraping of the pipe, use of stretch wrap is suggested in this procedure. In such cases, stretch wrap can help minimize or eliminate recontamination of the area already scraped or cleaned.

For quality control (QC) purposes, this procedure also suggests that a wipe that was used to clean the pipe with solvent be kept in a plastic bag as it can be tested for contaminants.

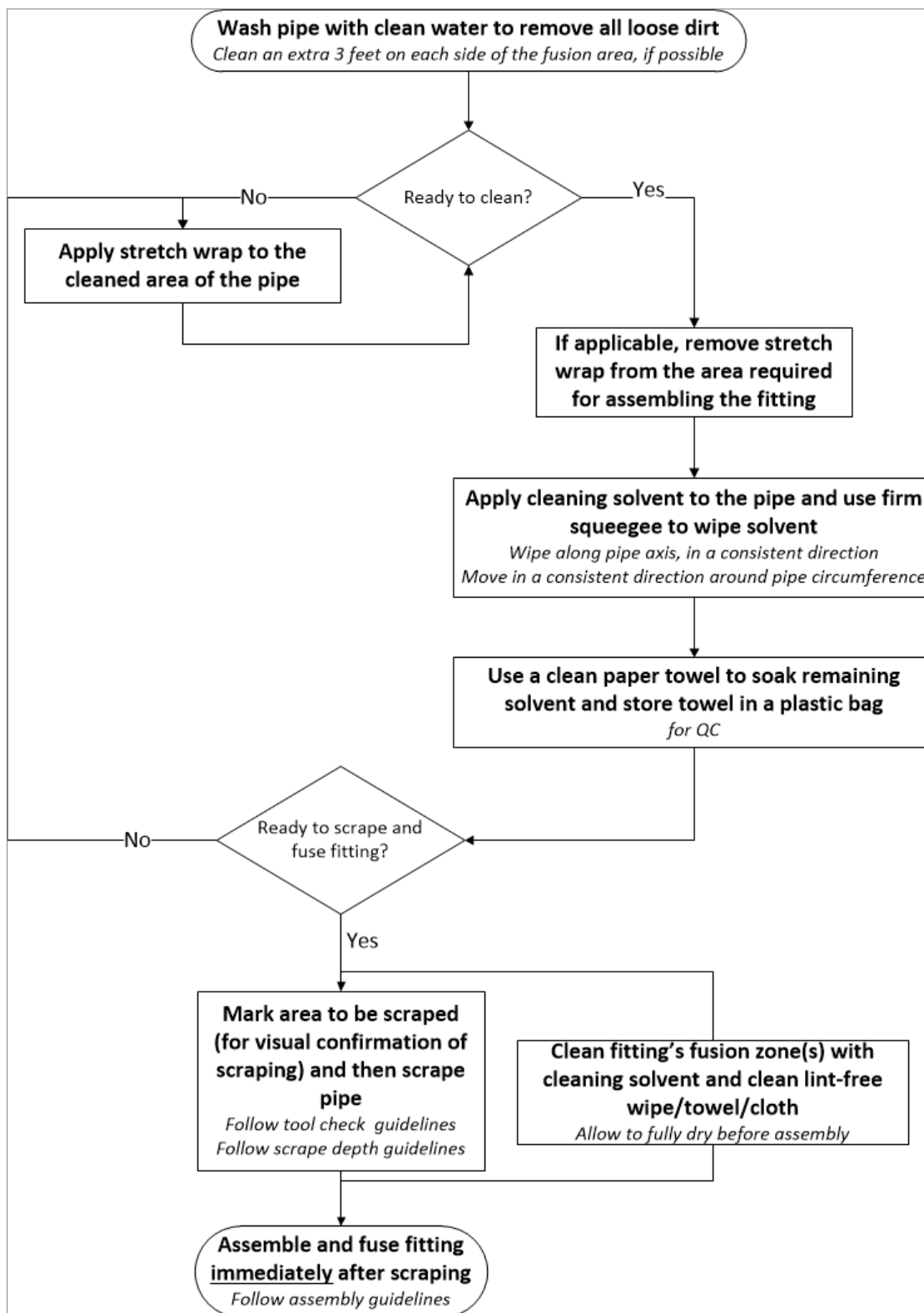

Figure 23. Top-level generic scraping procedure incorporating best-practices

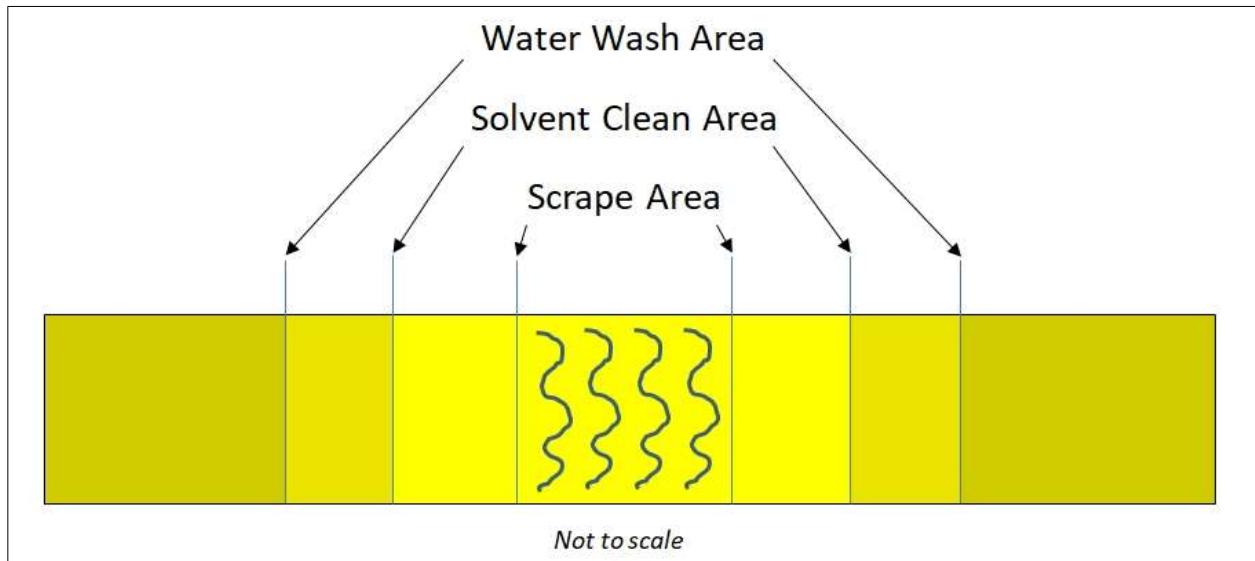

Figure 24. Schematic of cleaned areas for a saddle fitting

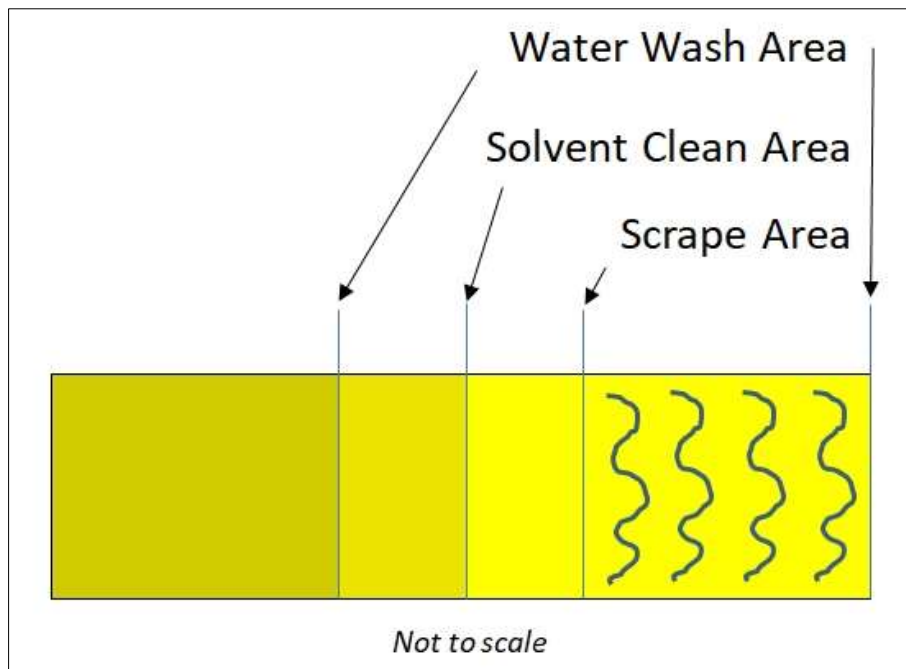

Figure 25. Schematic of cleaned areas for a coupling fitting

Potential Future Work

In light of the findings of this project, GTI suggested that additional testing be performed with a slight modification to the solvent cleaning and scraping technique, utilizing the remaining project budget. Project Sponsors approved this additional scope. This report will be amended with the results of the additional testing.

Another aspect of interest is to further explore solvent cleaning techniques and compare fusion ductility of joints fused after two or more wiping passes. Additional wiping passes may be rendered irrelevant by the results of the proposed scraping technique, however, it will still be applicable in cases where solvent cleaning is performed after scraping.

The commercially available handheld FTIR systems² could be evaluated under a future project as a field QA/QC tool that can detect contamination and oxidation before and/or after scraping.

² <http://www.agilent.com/en-us/products/ftir/ftir-compact-portable-systems>

Appendix A – Pipe Contamination Apparatus

The pipe contamination apparatus was constructed in order to contaminate pipe in a consistent manner with a fine powder (talc, bentonite). The apparatus was built to meet the specifications given in the UK standard WIS-32-4-08 *Specification for the Fusion Jointing of Polyethylene Pressure Pipeline Systems Using PE80 and PE100 Materials* (see **Figure 26**).

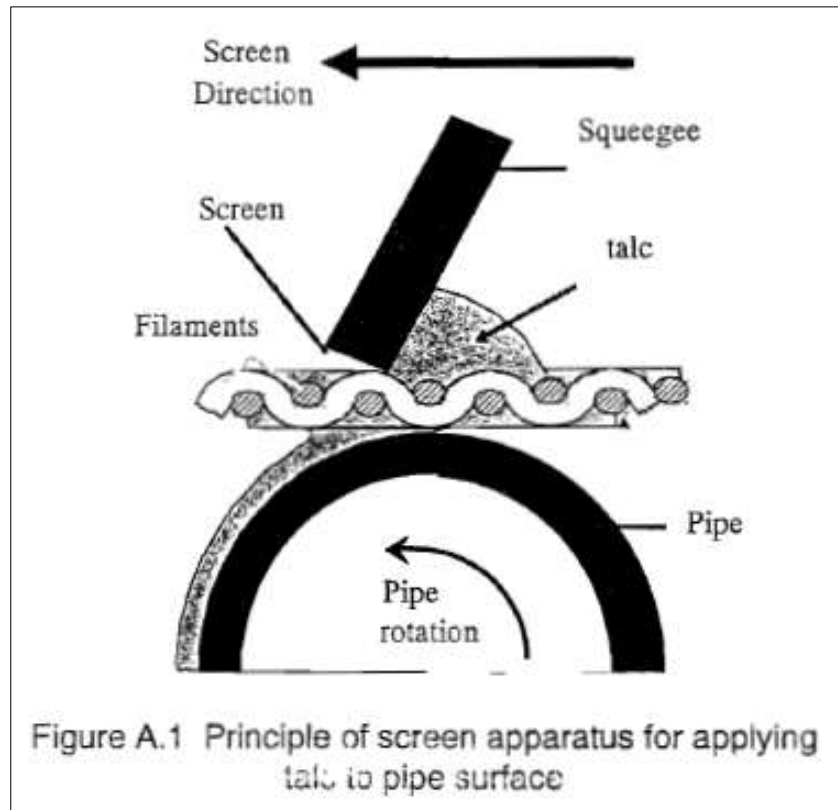

Figure 26. Figure A.1 from WIS-32-4-08

The apparatus has a computer controlled, electrically driven screen tray and a pneumatically actuated squeegee. Tray speed and movement distance are programmable, and squeegee force and manually adjustable via precision air pressure regulators. The pipe underneath the strainer is rotated synchronously with the motion of the tray. The apparatus is also adjustable to accommodate a range of pipe samples from 1/2" CTS to 8" IPS.

Figure 27 through **Figure 30** show details of the pipe contamination apparatus.

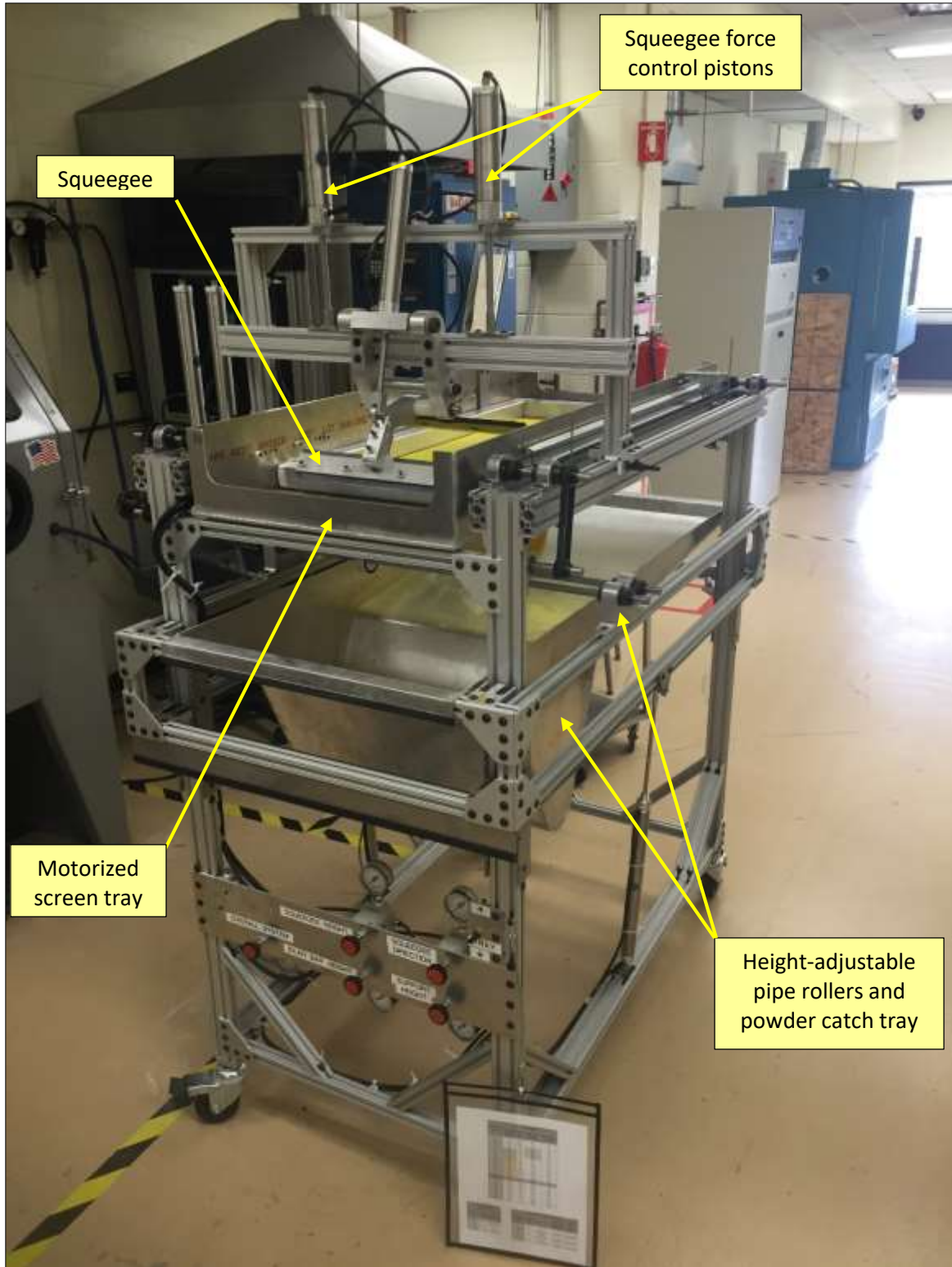

Figure 27. Pipe contamination apparatus

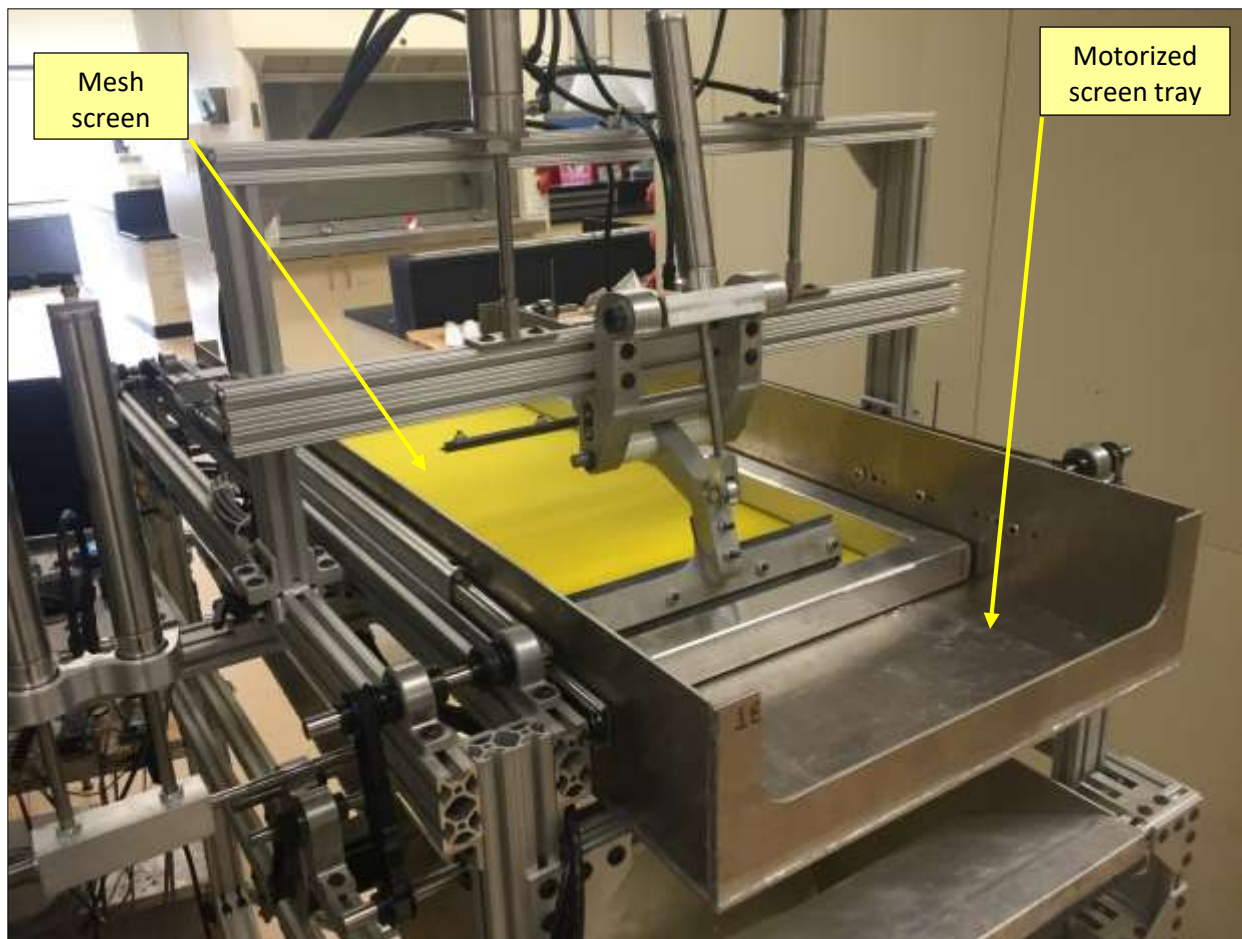

Figure 28. View of motorized strainer carriage, squeegee lowered onto strainer

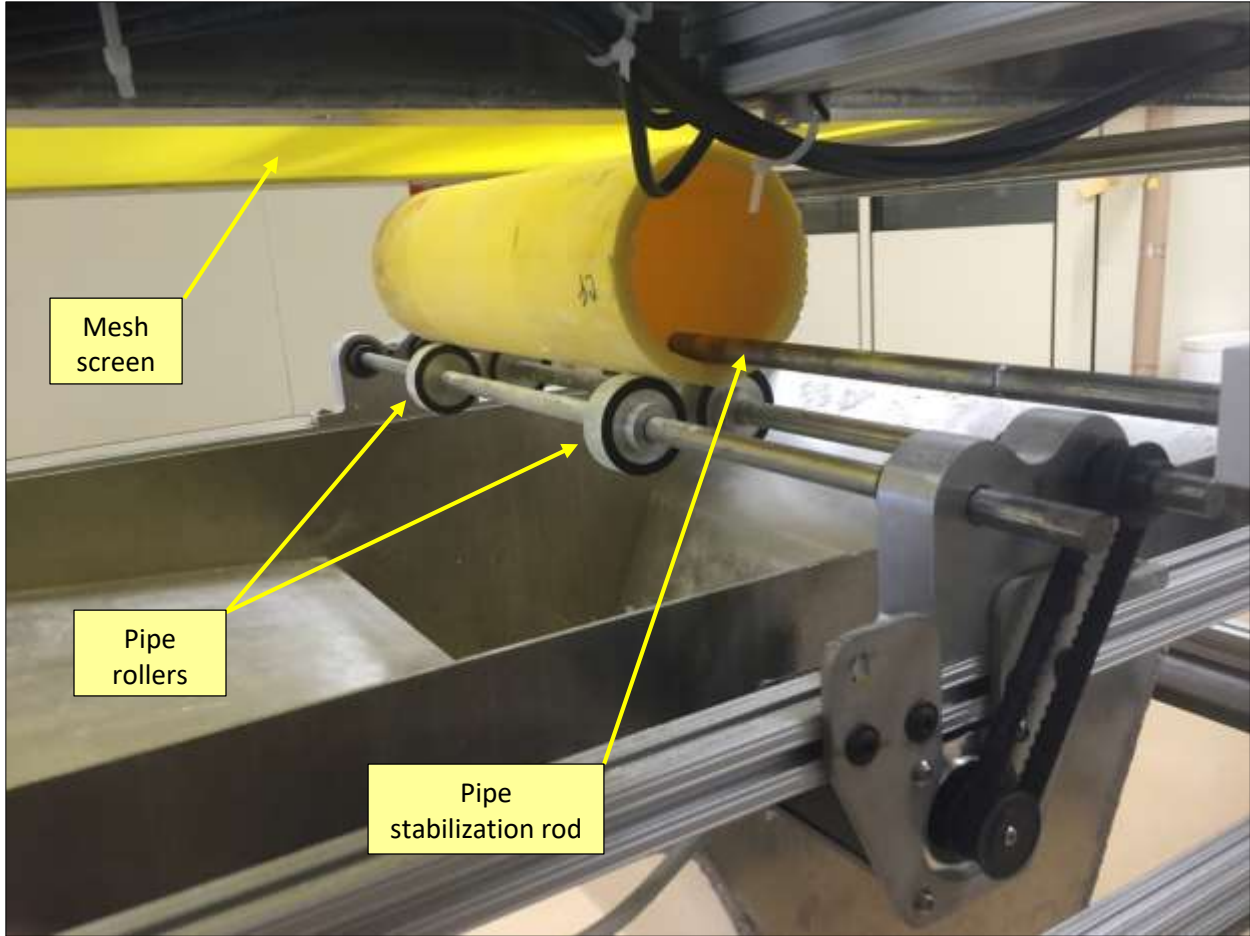

Figure 29. 2" IPS pipe sample in place for contamination



Figure 30. Pipe contaminator control console and electronics box

Appendix B – Post Decohesion FTIR Test Results

The following figures show the test results of the decohesion tests and FTIR data where applicable. Circles on photographs indicate the locations where FTIR readings were taken and they are color-coded to match the corresponding FTIR spectra figure.

Taller contaminant peaks indicate less contaminant was removed.

172318-001

172318-001	172395-001	Talc	99% Isopropanol	Lint-Free Wipe
------------	------------	------	-----------------	----------------

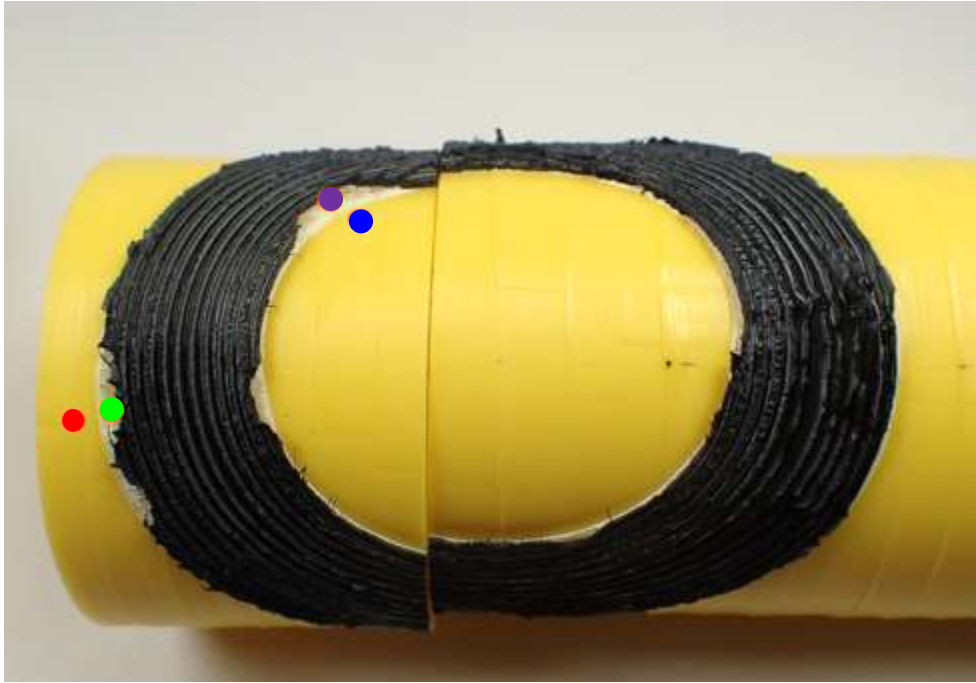

Figure 31. Sample 172318-001, decohesion test result

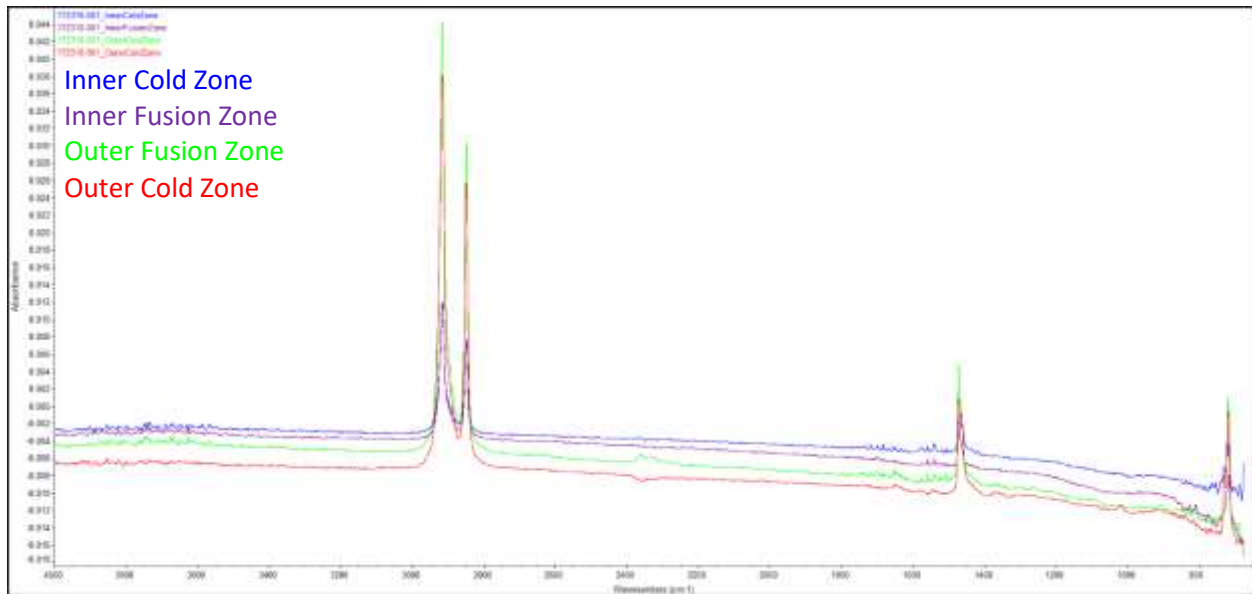

Figure 32. Sample 172318-001, FTIR spectra from decohesion test result

172318-002

172318-002	172395-002	Talc	99% Isopropanol	Cotton Cloth Rag
------------	------------	------	-----------------	------------------

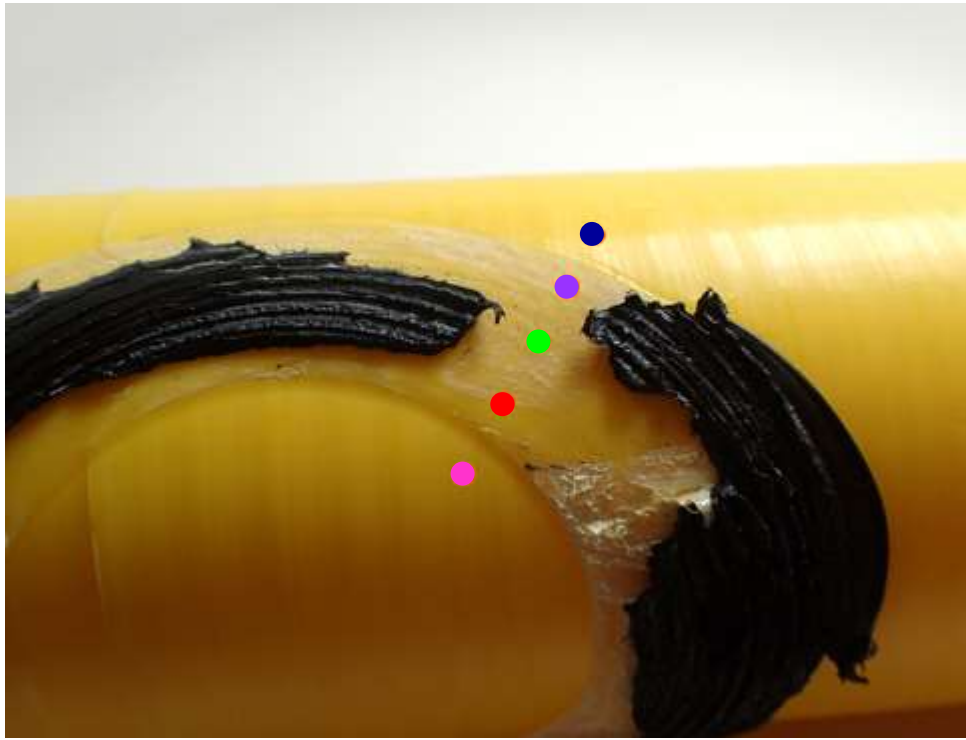

Figure 33. Sample 172318-002, decohesion test result

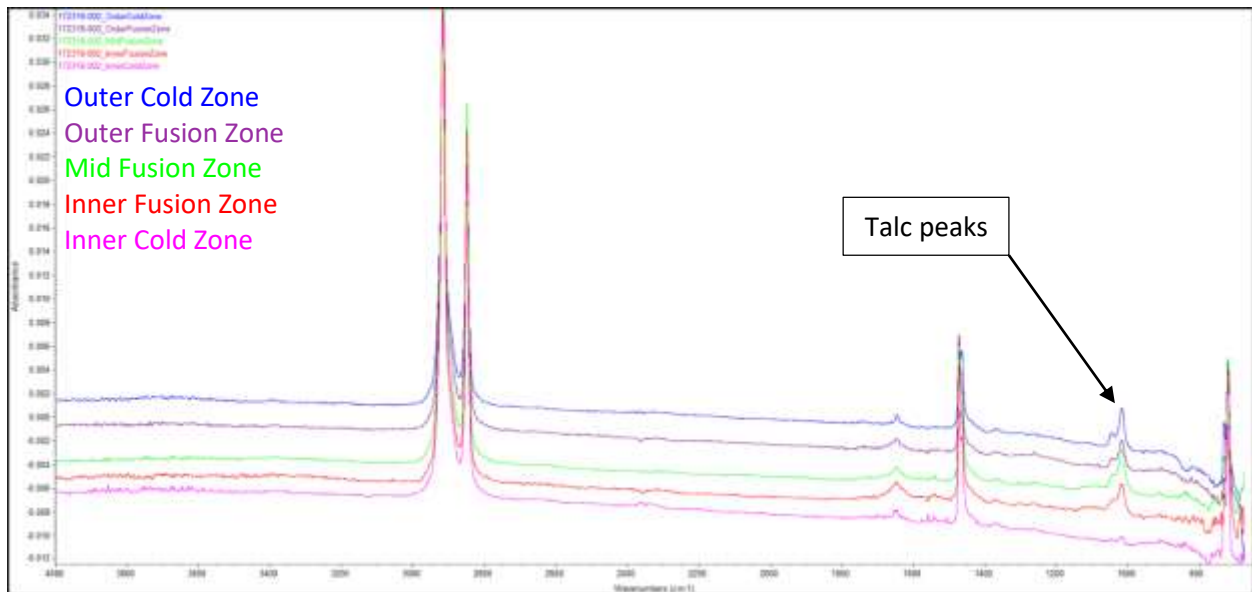

Figure 34. Sample 172318-002, FTIR spectra from decohesion test result

172318-003

172318-003	172395-003	Talc	91% Isopropanol	Lint-Free Wipe
------------	------------	------	-----------------	----------------

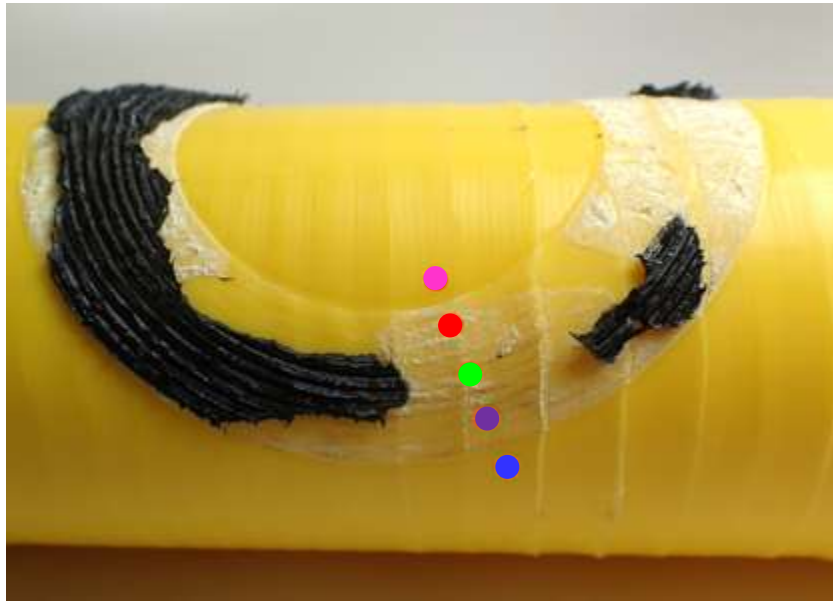

Figure 35. Sample 172318-003, decohesion test result

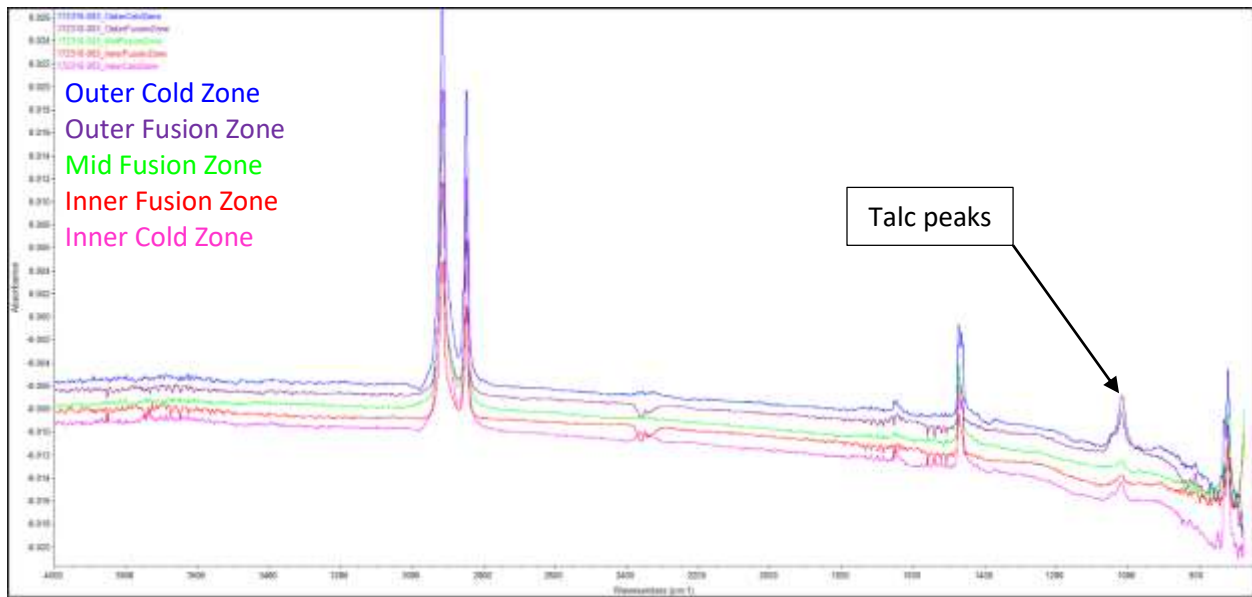

Figure 36. Sample 172318-003, FTIR spectra from decohesion test result

172318-004

172318-004	172395-004	Talc	91% Isopropanol	Cotton Cloth Rag
------------	------------	------	-----------------	------------------

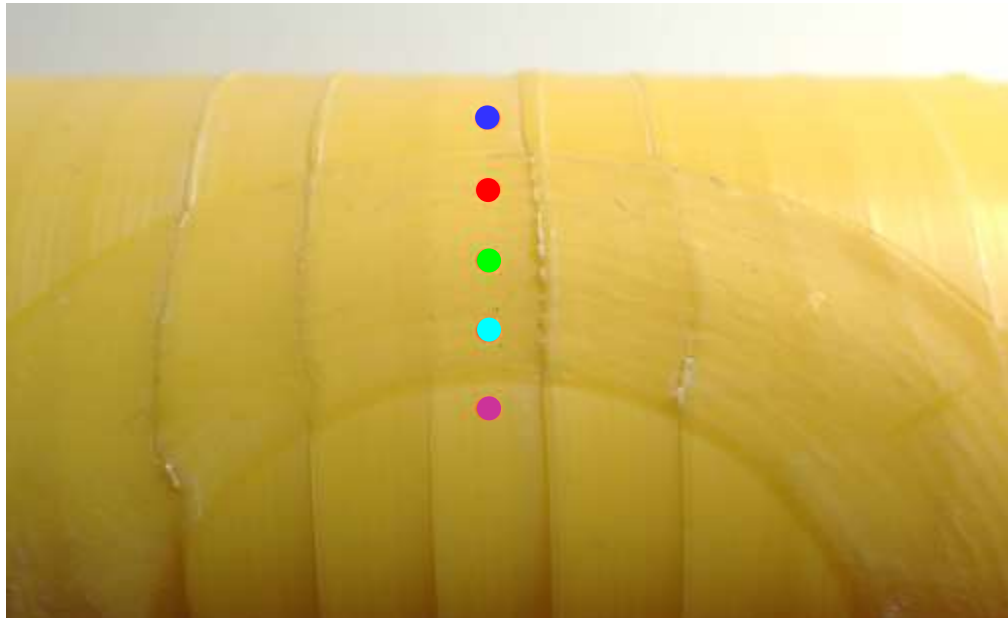

Figure 37. Sample 172318-004, decohesion test result

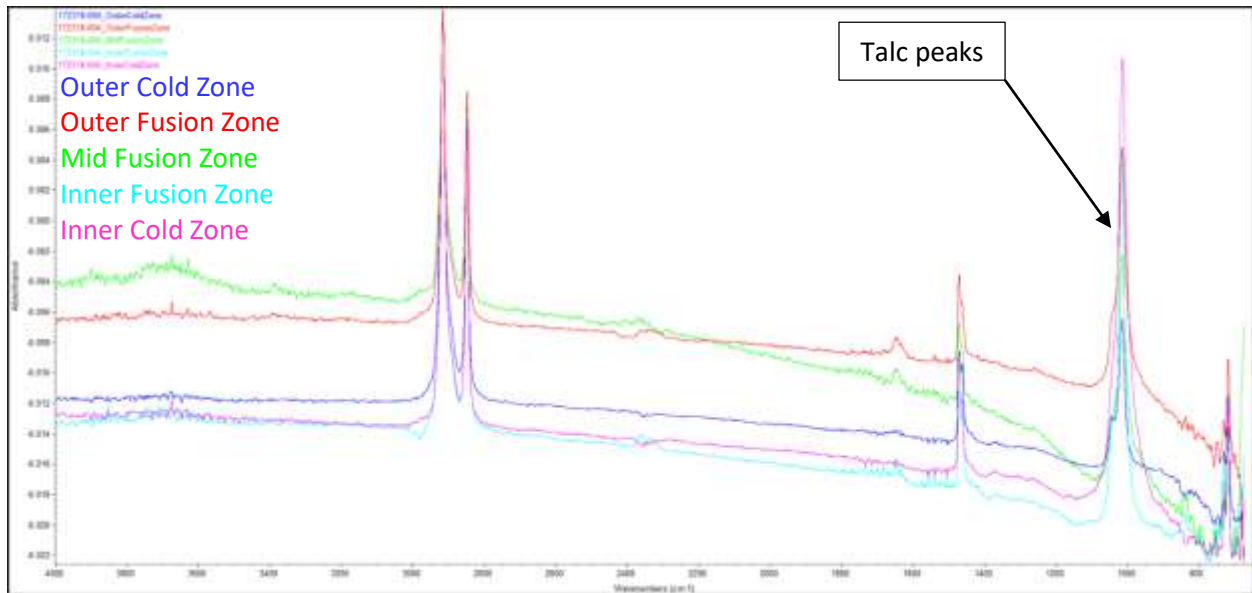

Figure 38. Sample 172318-004, FTIR spectra from decohesion test result

172318-005

172318-005	172395-005	Talc	99% Isopropanol	Lint-Free Wipe
------------	------------	------	-----------------	----------------

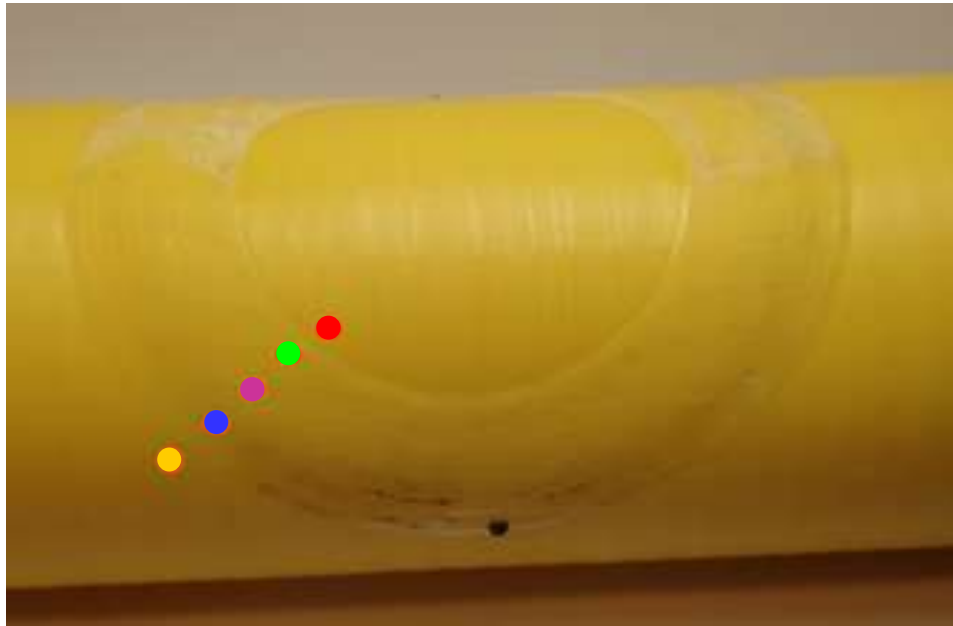

Figure 39. Sample 172318-005, decohesion test result

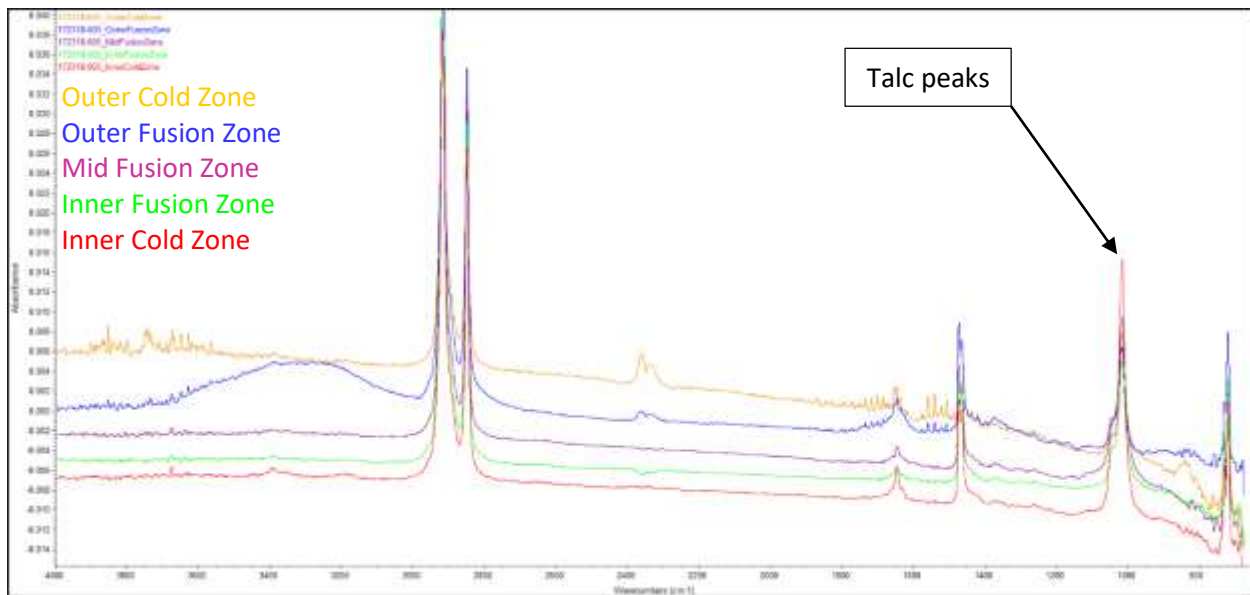

Figure 40. Sample 172318-005, FTIR spectra from decohesion test result

172318-006

172318-006	172395-006	Talc	99% Isopropanol	Cotton Cloth Rag
------------	------------	------	-----------------	------------------

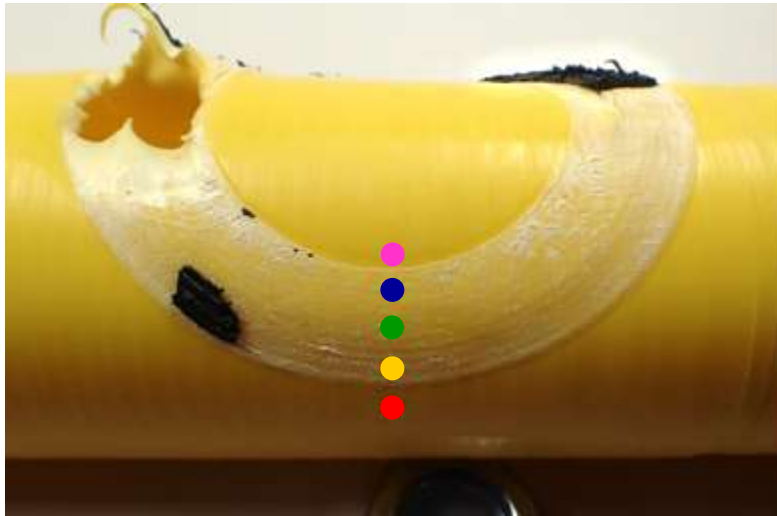

Figure 41. Sample 172318-006, decohesion test result

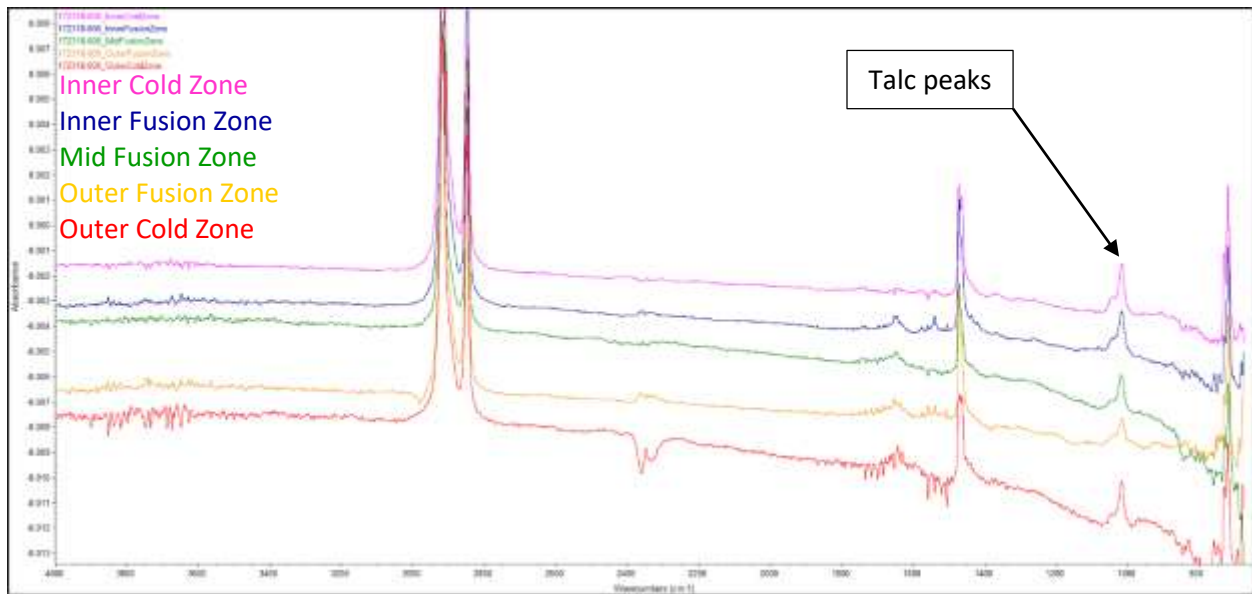

Figure 42. Sample 172318-006, FTIR spectra from decohesion test result

172318-007

172318-007	172395-007	Talc	99% Isopropanol	Paper Towel
------------	------------	------	-----------------	-------------

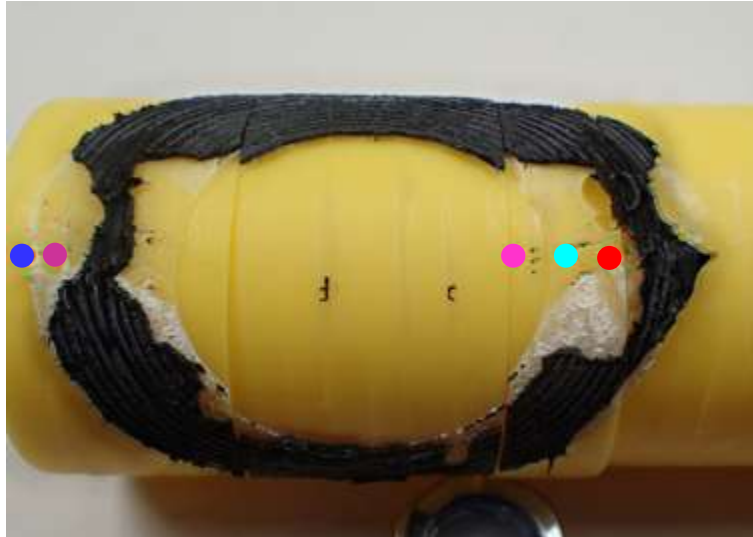

Figure 43. Sample 172318-007, decohesion test result

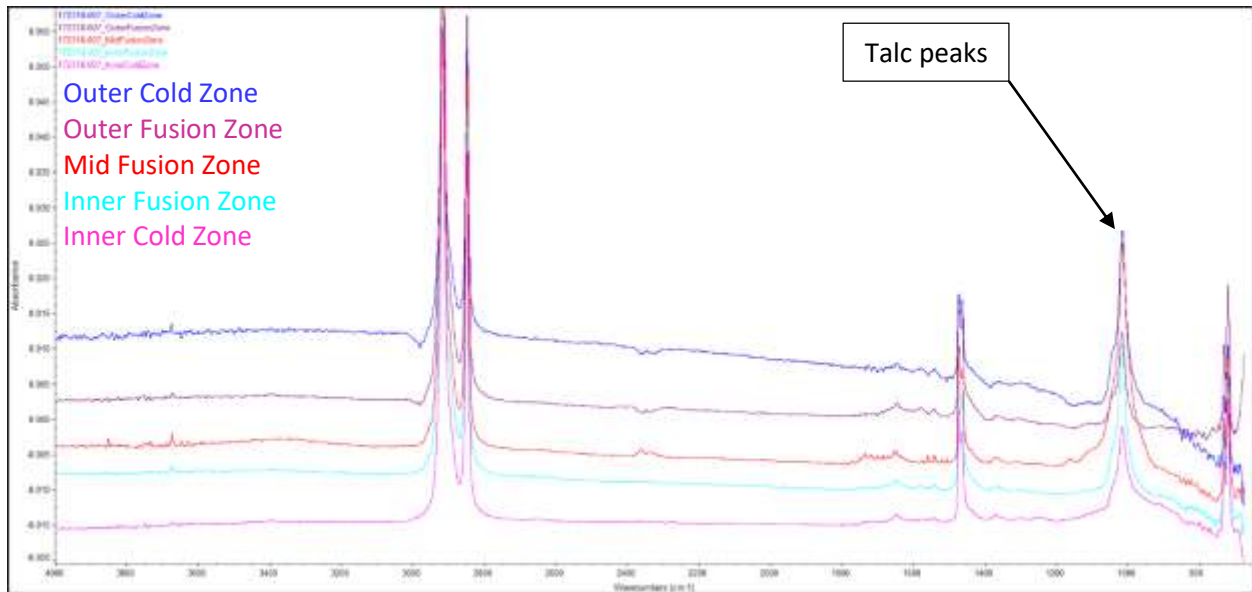

Figure 44. Sample 172318-007, FTIR spectra from decohesion test result

172318-008

172318-008	172395-008	Talc	99% Isopropanol	Paper Towel
------------	------------	------	-----------------	-------------

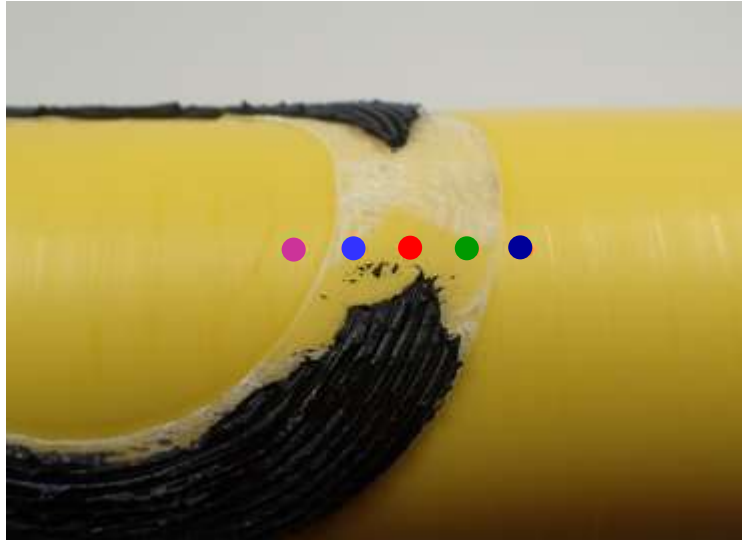

Figure 45. Sample 172318-008, decohesion test result

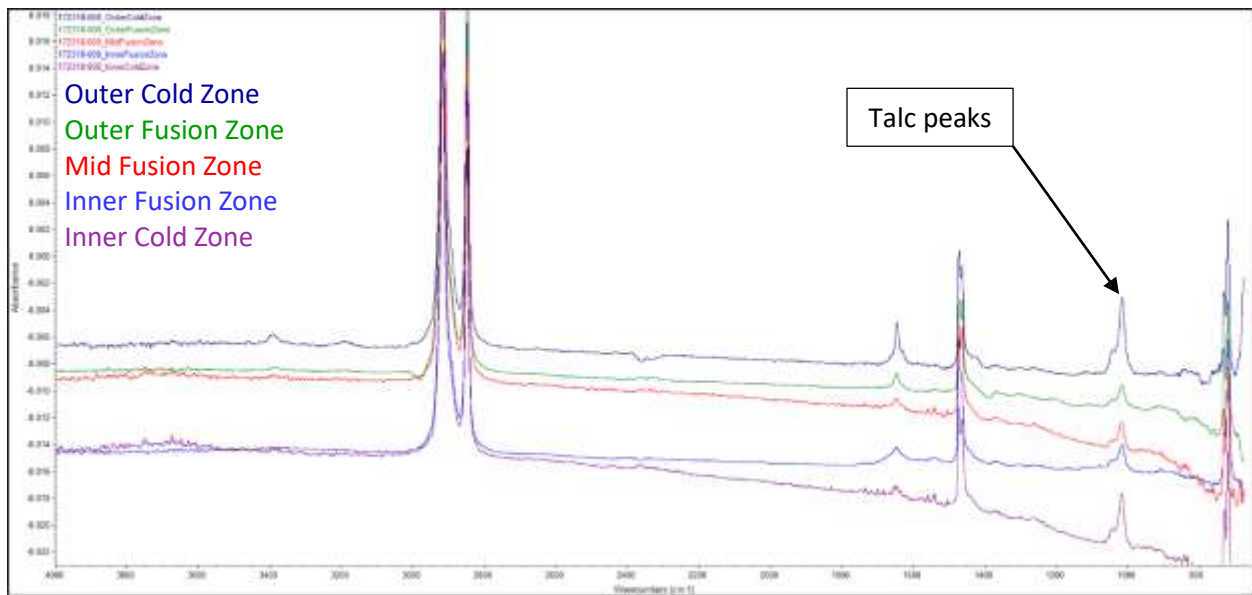

Figure 46. Sample 172318-008, FTIR spectra from decohesion test result

172318-009

172318-009	172395-009	Talc	91% Isopropanol	Paper Towel
------------	------------	------	-----------------	-------------

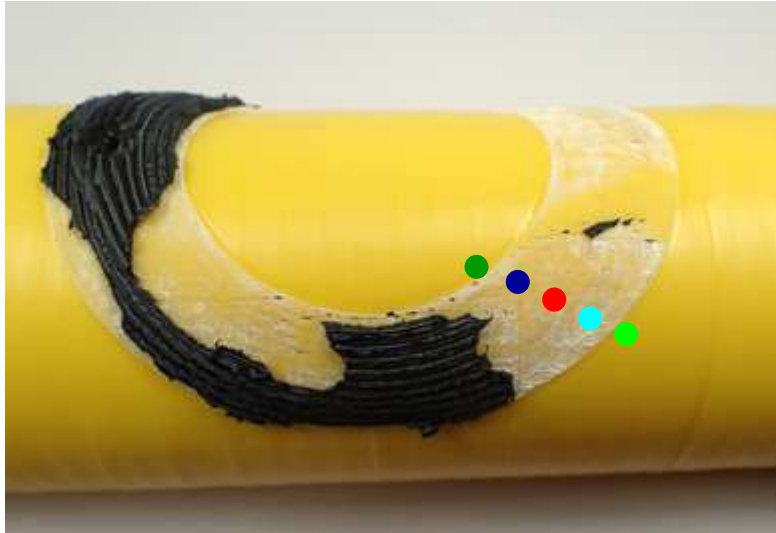

Figure 47. Sample 172318-009, decohesion test result

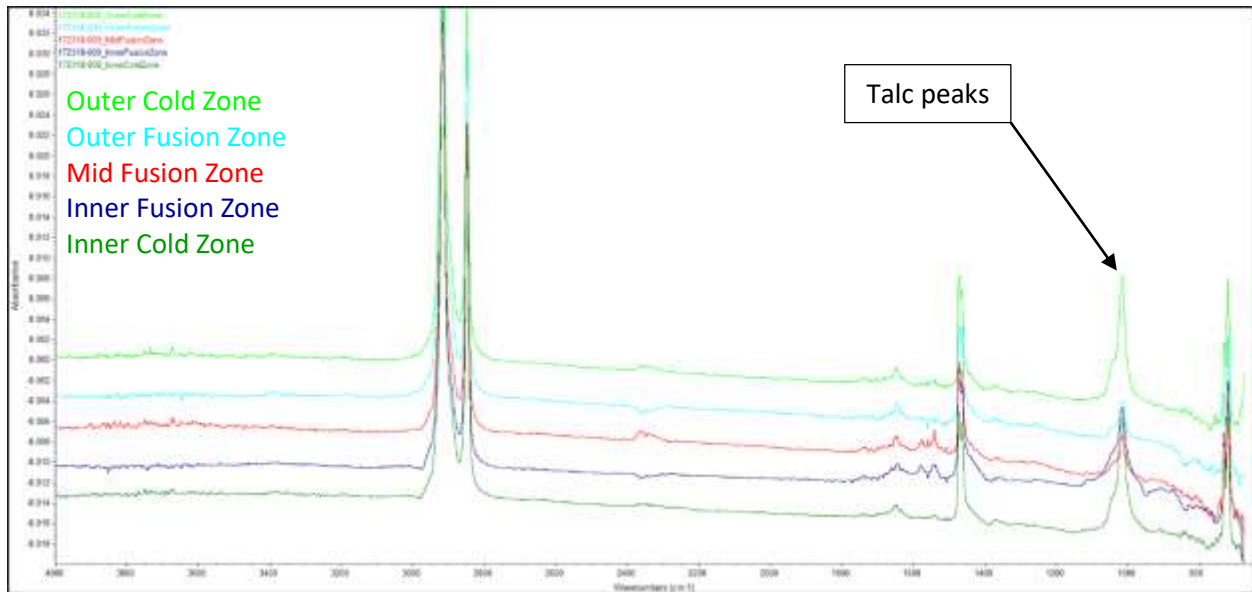

Figure 48. Sample 172318-009, FTIR spectra from decohesion test result

172318-010

172318-010	172395-010	Talc	91% Isopropanol	Paper Towel
------------	------------	------	-----------------	-------------

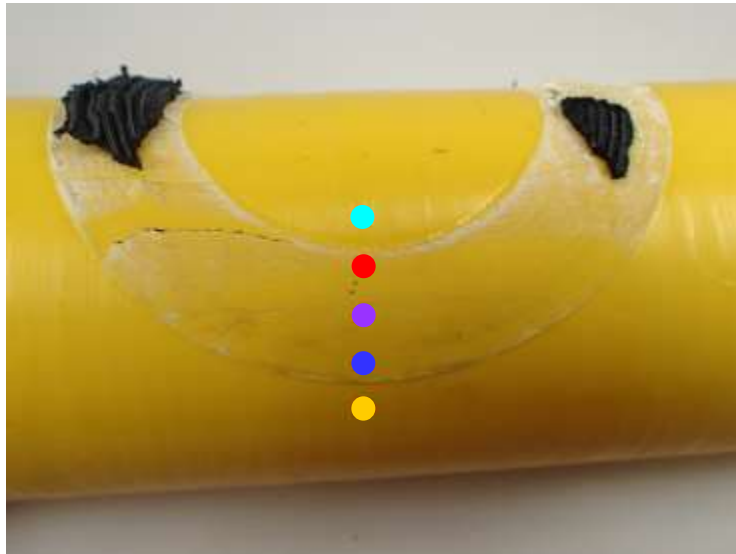

Figure 49. Sample 172318-010, decohesion test result

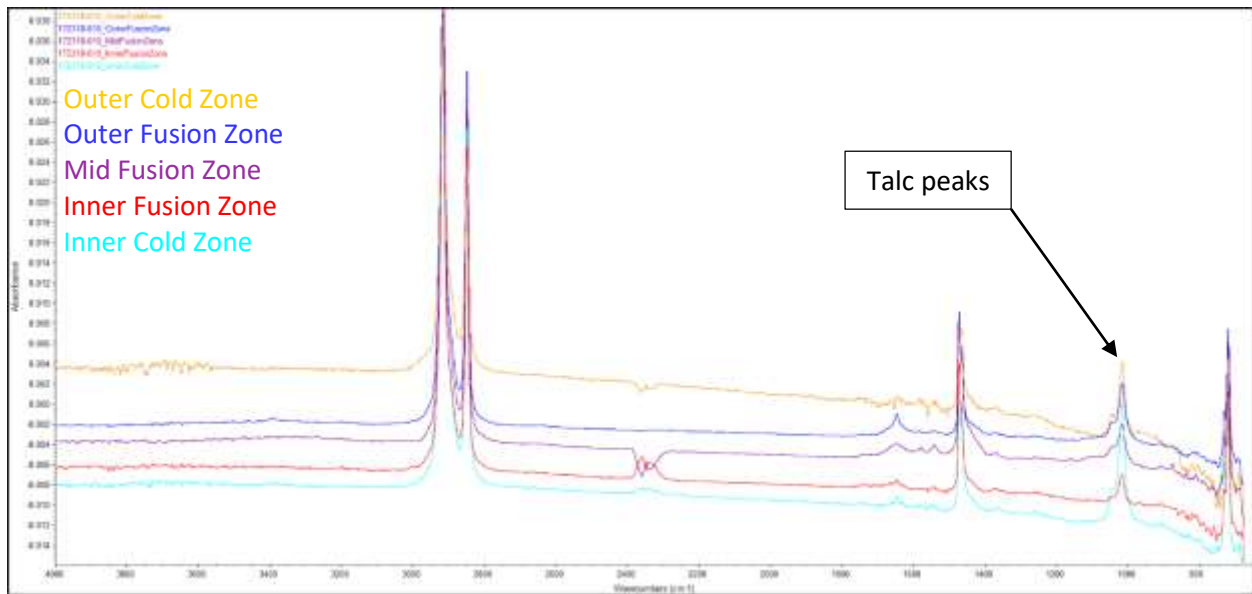

Figure 50. Sample 172318-010, FTIR spectra from decohesion test result

172318-011

172318-011	172395-013	Talc	91% Isopropanol	Lint-Free Wipe
------------	------------	------	-----------------	----------------

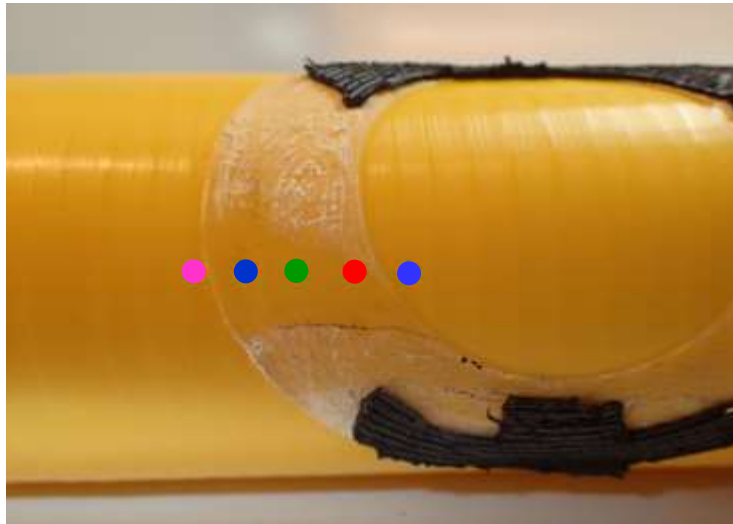

Figure 51. Sample 172318-011, decohesion test result

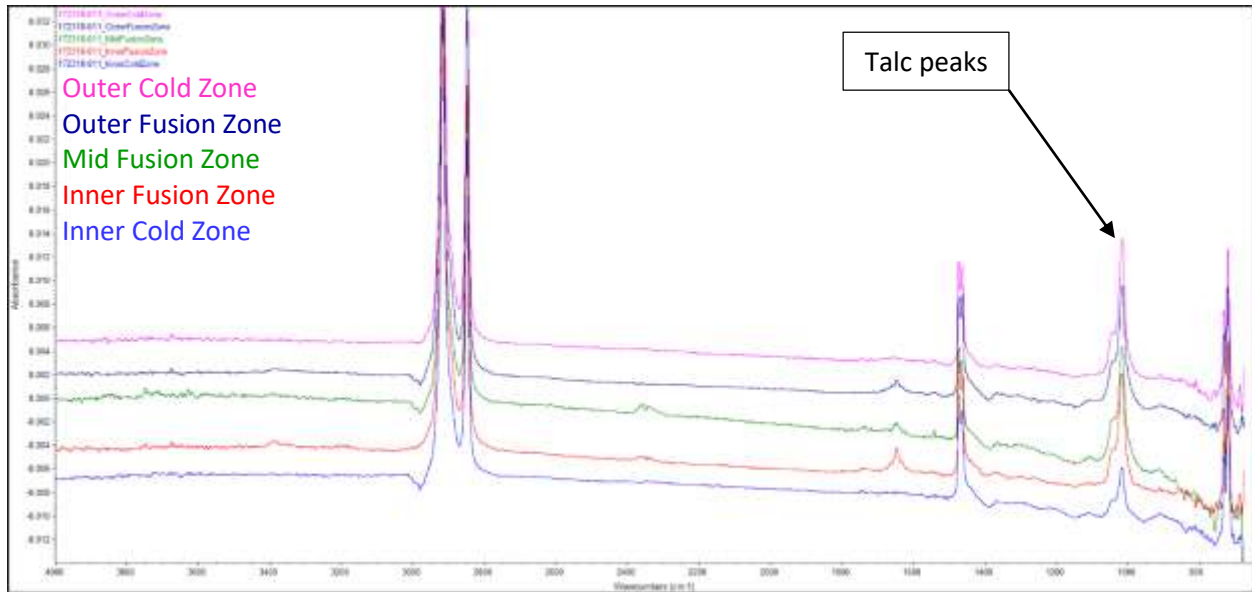

Figure 52. Sample 172318-011, FTIR spectra from decohesion test result

172318-012

172318-012	172395-022	Talc	91% Isopropanol	Cotton Cloth Rag
------------	------------	------	-----------------	------------------

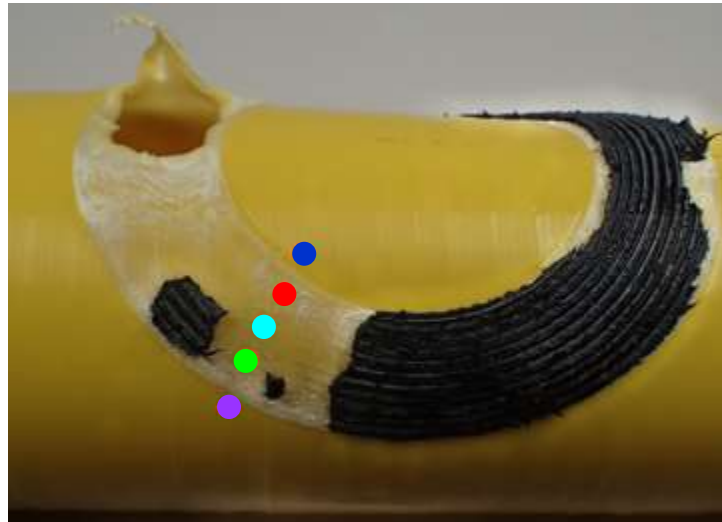

Figure 53. Sample 172318-012, decohesion test result

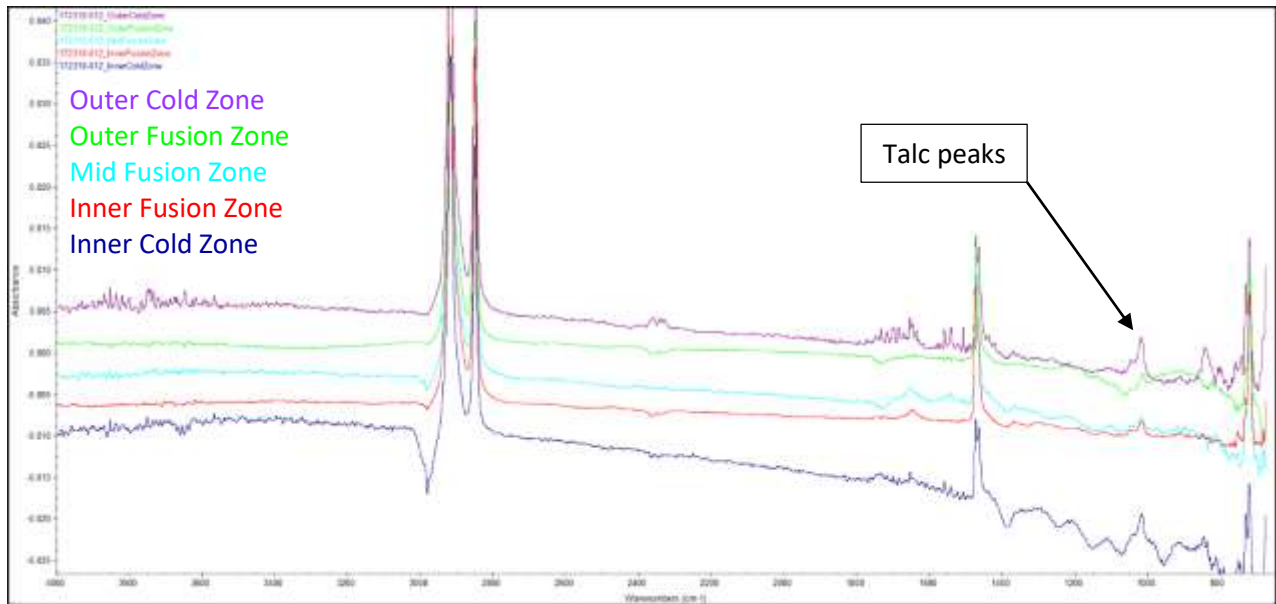

Figure 54. Sample 172318-012, FTIR spectra from decohesion test result

172318-013

172318-013	172395-025	Talc	Acetone	Lint-Free Wipe
------------	------------	------	---------	----------------

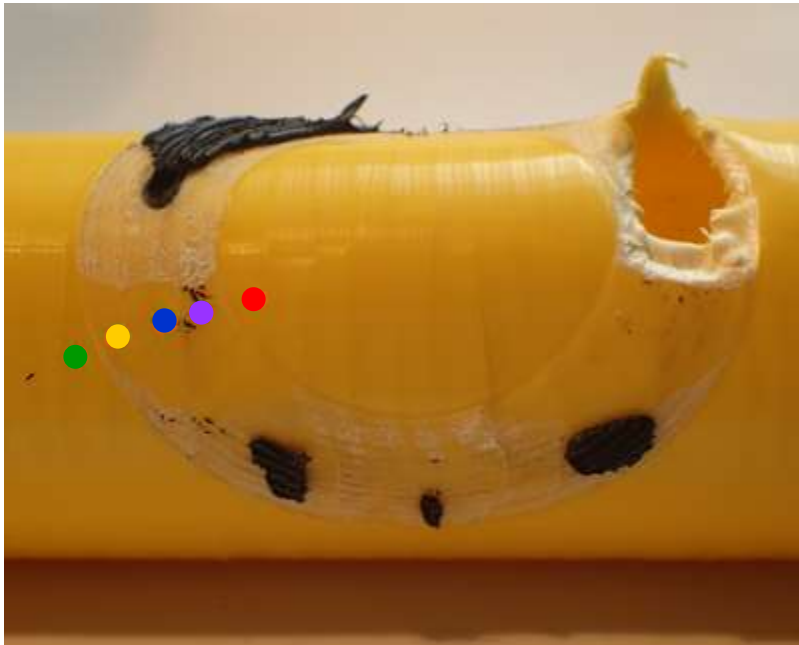

Figure 55. Sample 172318-013, decohesion test result

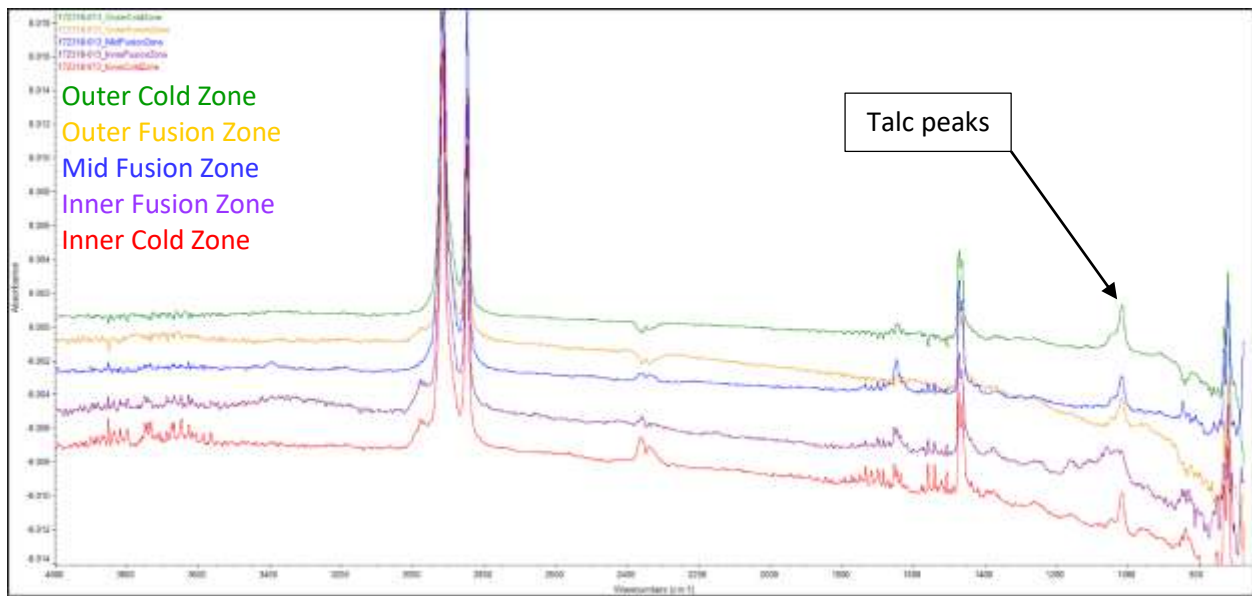

Figure 56. Sample 172318-013, FTIR spectra from decohesion test result

172318-014

172318-014	172395-026	Talc	Acetone	Lint-Free Wipe
------------	------------	------	---------	----------------

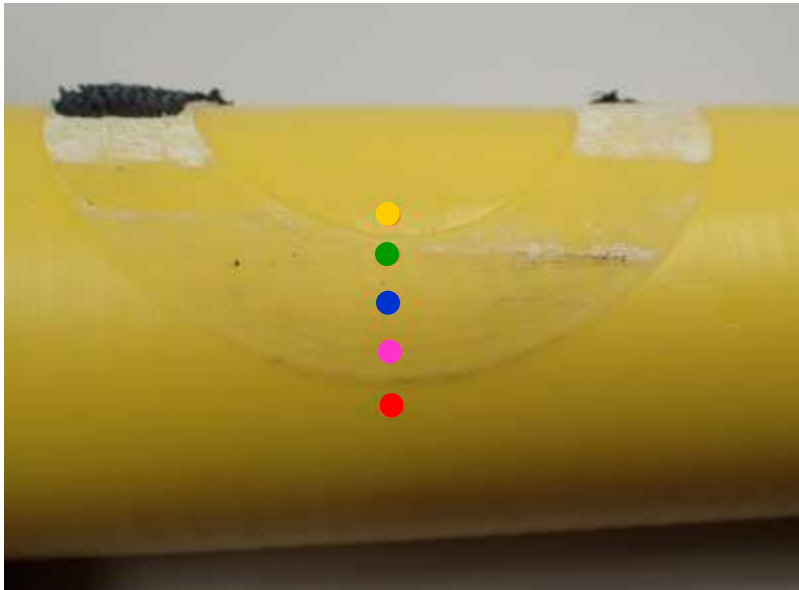

Figure 57. Sample 172318-014, decohesion test result

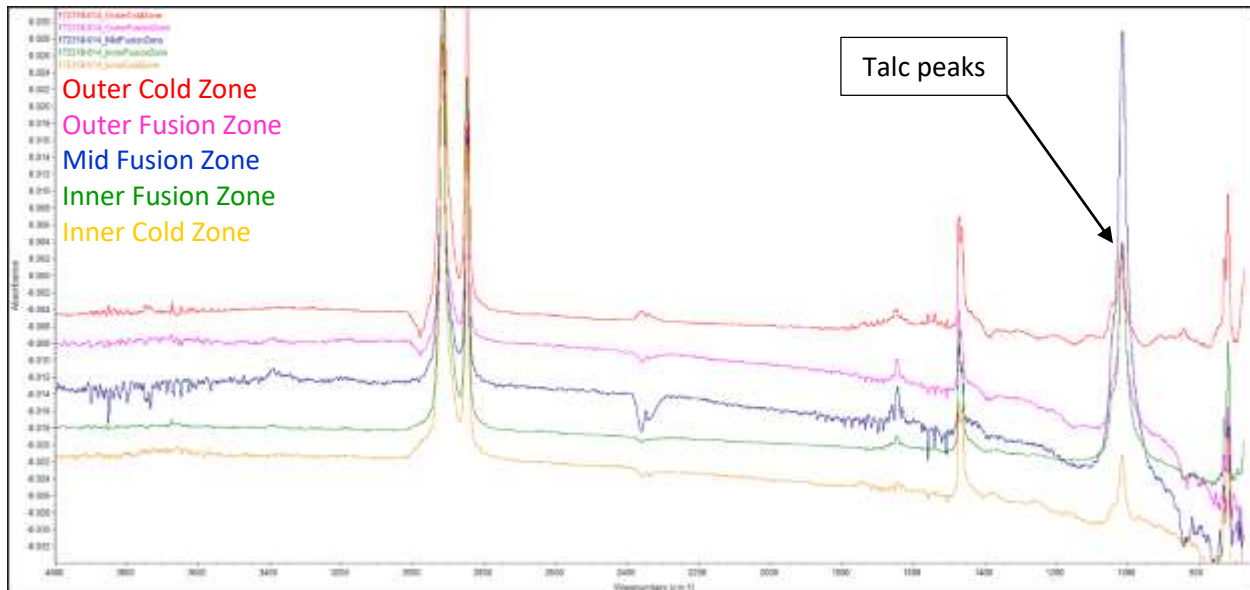

Figure 58. Sample 172318-014, FTIR spectra from decohesion test result

172318-015

172318-015	172395-029	Talc	Acetone	Cotton Cloth Rag
------------	------------	------	---------	------------------

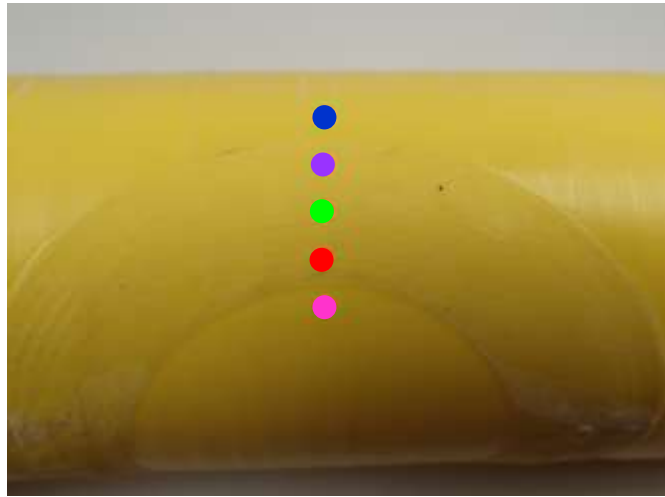

Figure 59. Sample 172318-015, decohesion test result

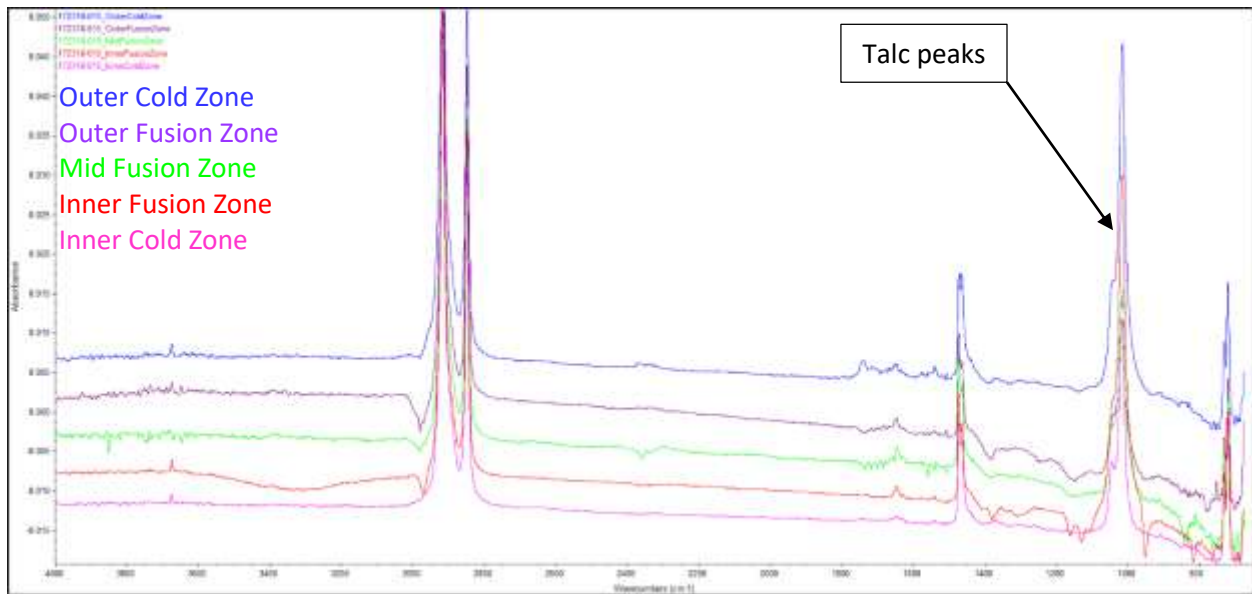

Figure 60. Sample 172318-015, FTIR spectra from decohesion test result

172318-016

172318-016	172395-030	Talc	Acetone	Cotton Cloth Rag
------------	------------	------	---------	------------------

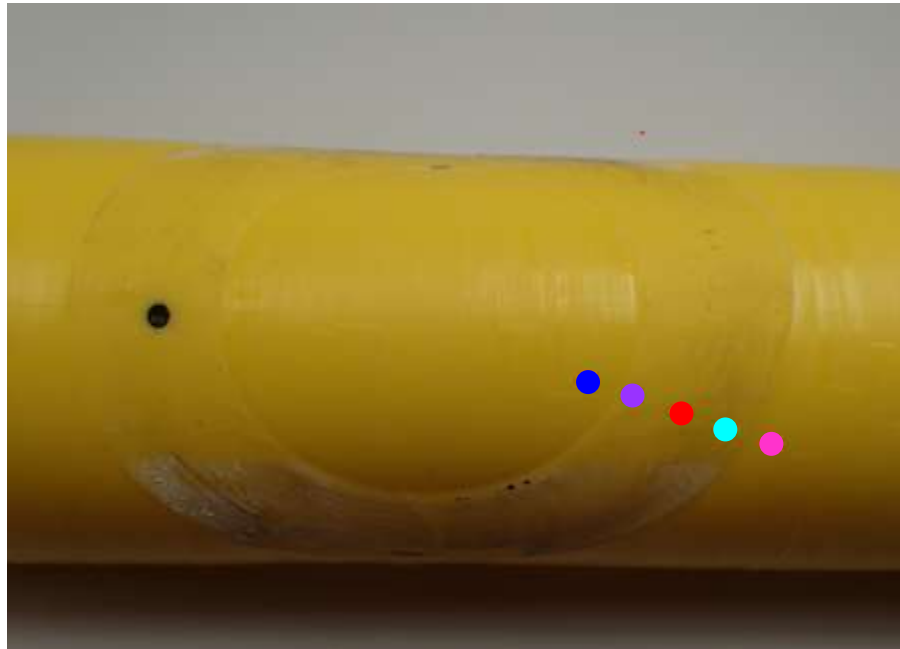

Figure 61. Sample 172318-016, decohesion test result

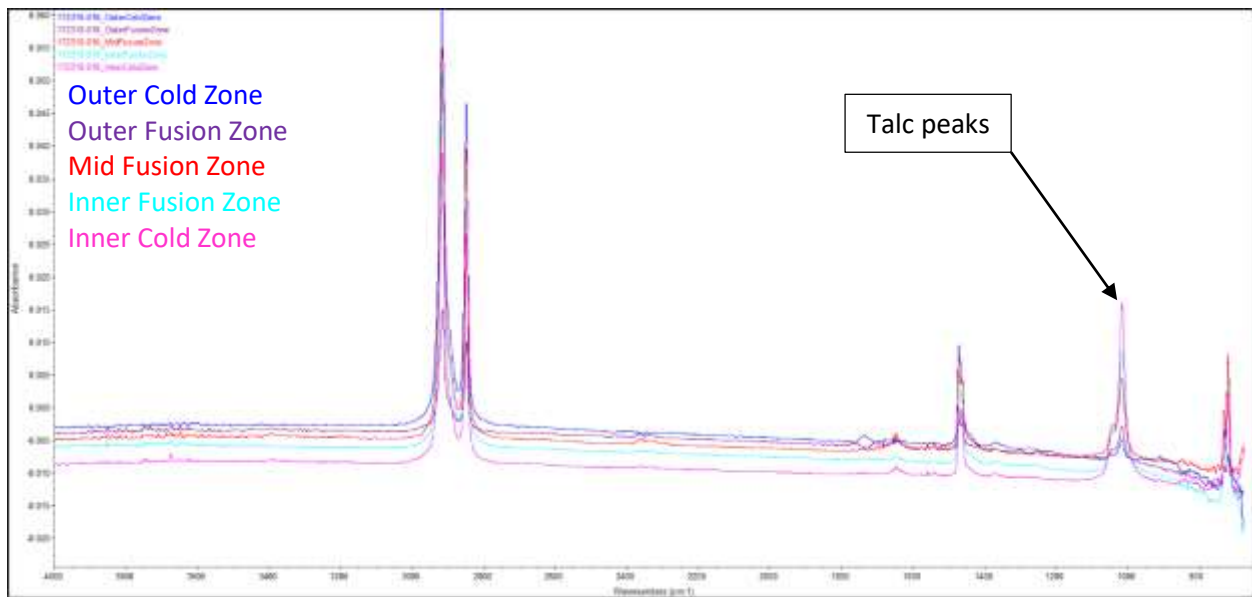

Figure 62. Sample 172318-016, FTIR spectra from decohesion test result

172318-017

172318-017	172395-033	Talc	Acetone	Paper Towel
------------	------------	------	---------	-------------

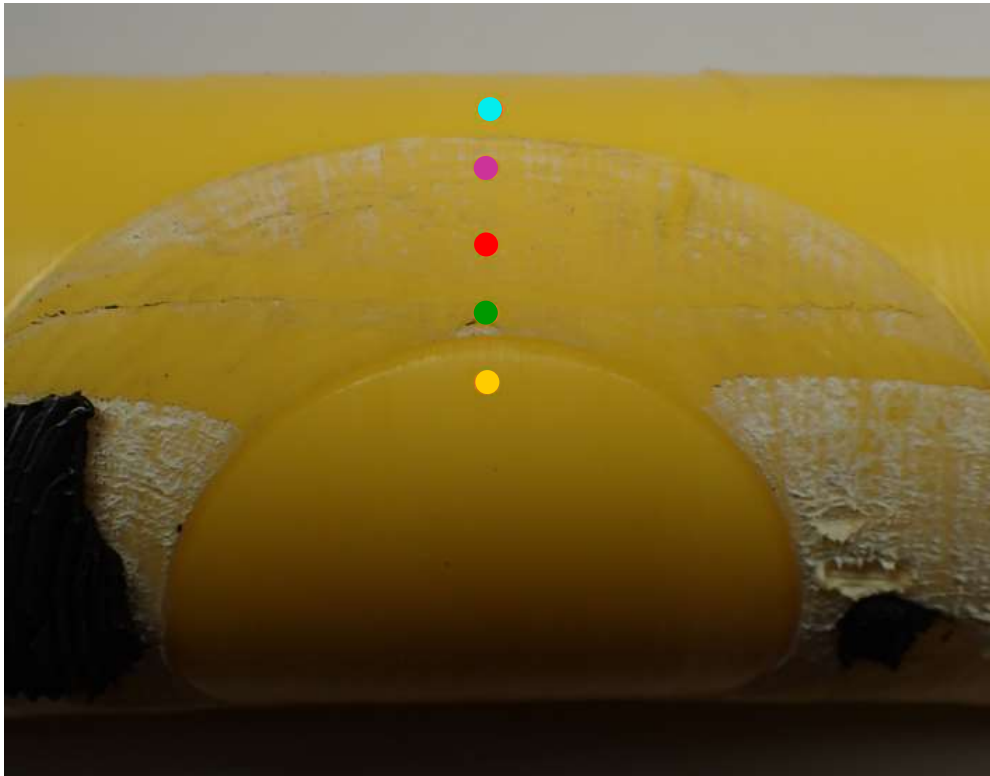

Figure 63. Sample 172318-017, decohesion test result

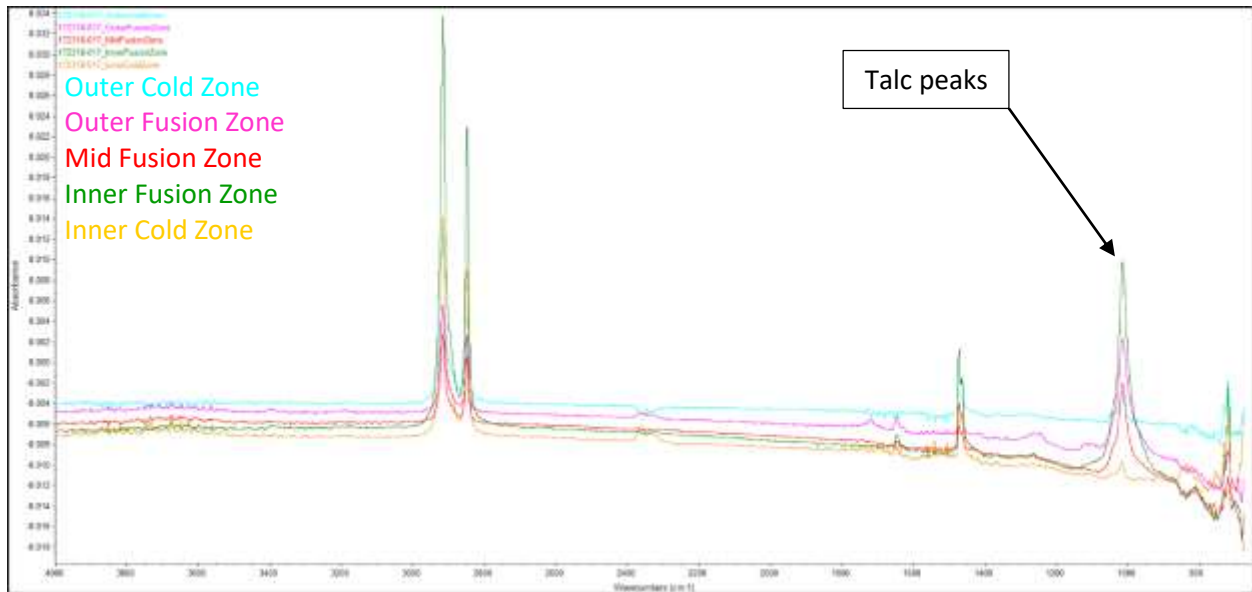

Figure 64. Sample 172318-017, FTIR spectra from decohesion test result

172318-018

172318-018	172395-034	Talc	Acetone	Paper Towel
------------	------------	------	---------	-------------

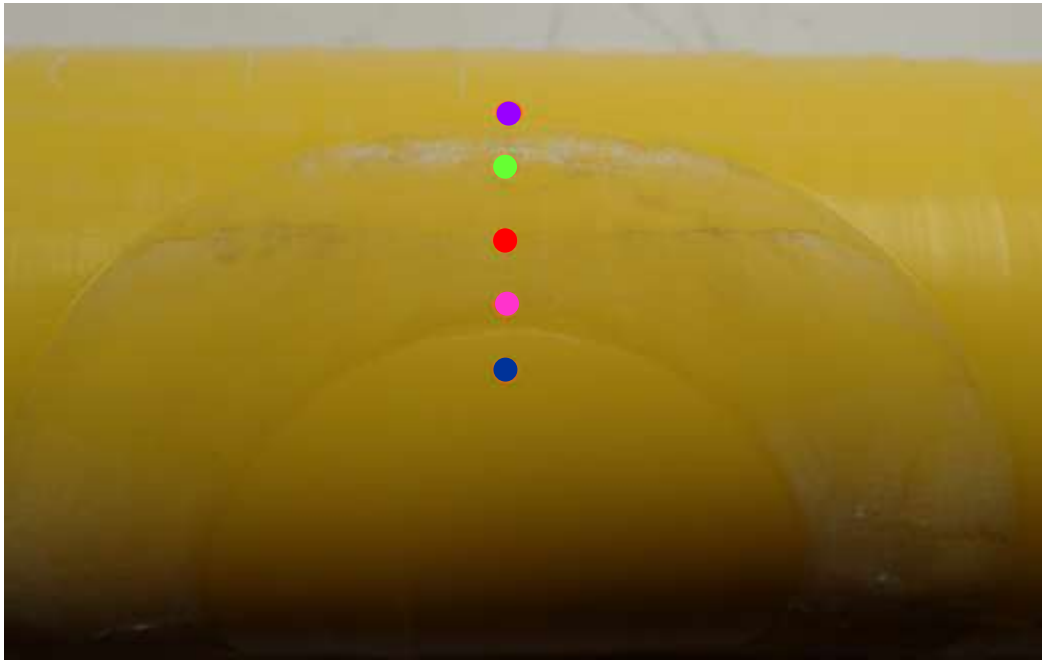

Figure 65. Sample 172318-018, decohesion test result

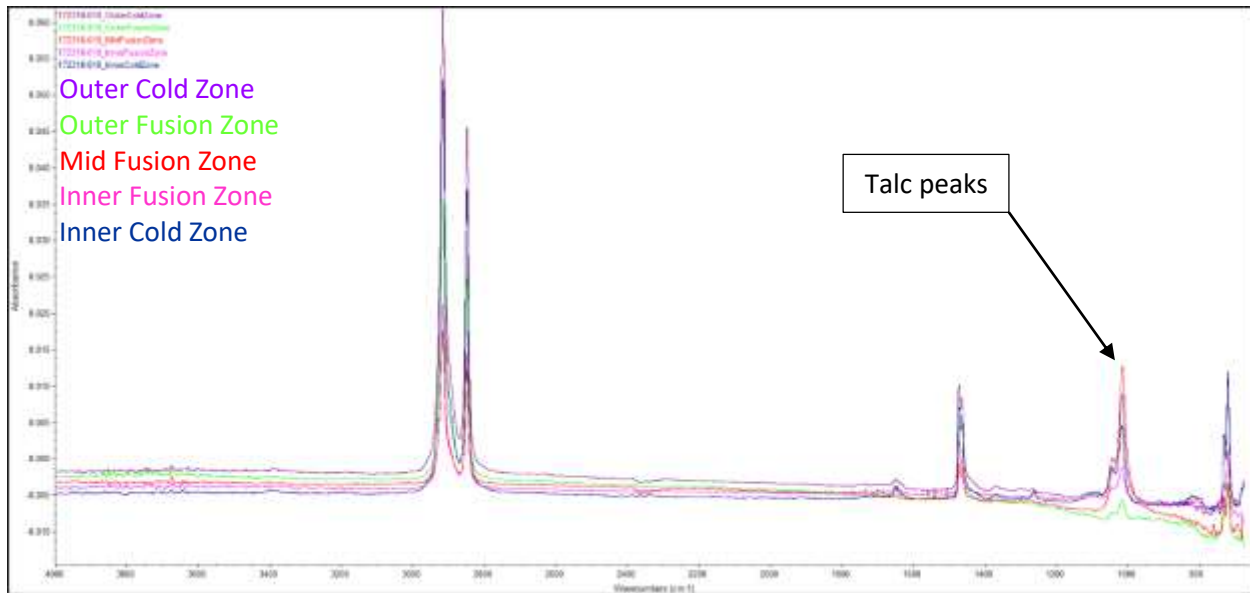

Figure 66. Sample 172318-018, FTIR spectra from decohesion test result

172318-019

172318-019	172395-037	Talc	None	None
------------	------------	------	------	------

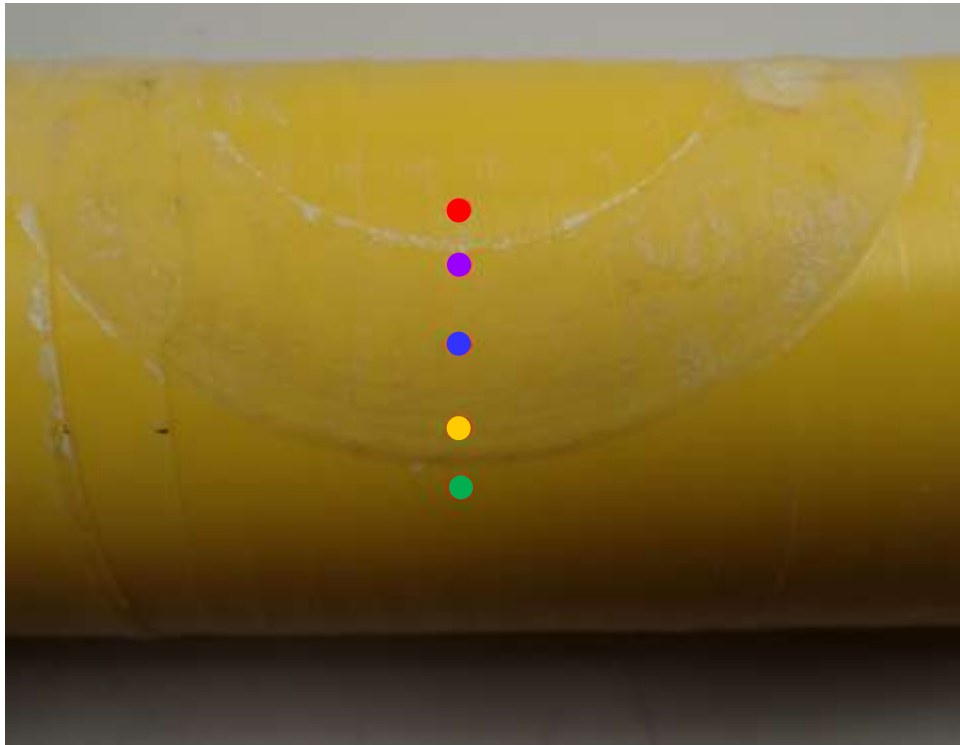

Figure 67. Sample 172318-019, decohesion test result

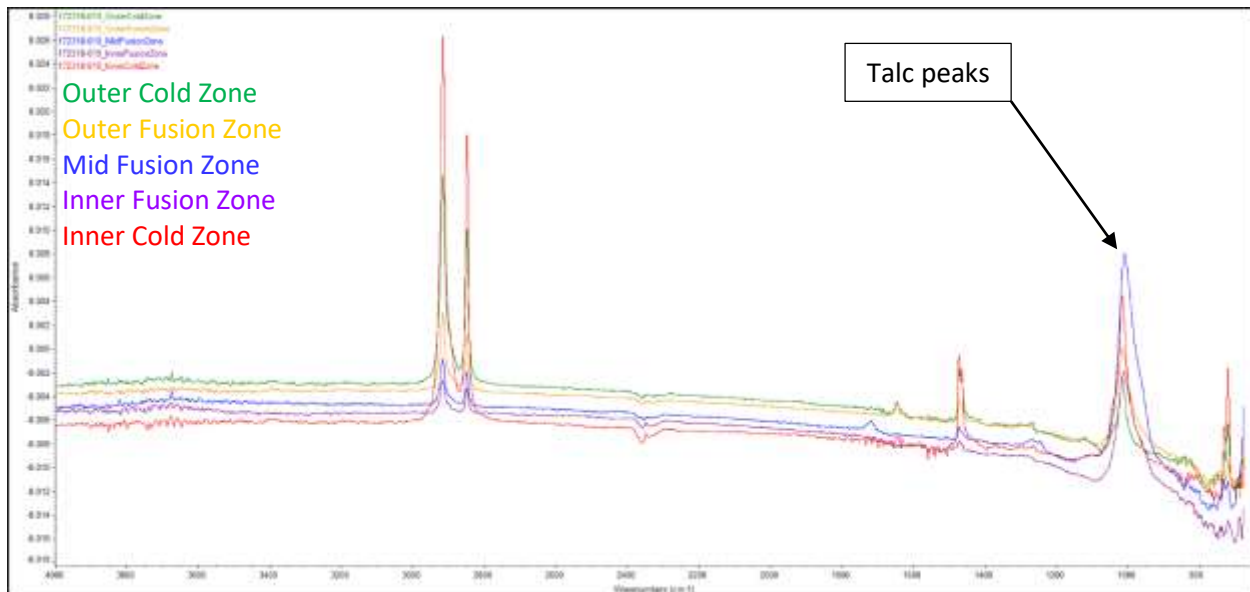

Figure 68. Sample 172318-019, FTIR spectra from decohesion test result

172318-020

172318-020	172395-038	Talc	None	None
------------	------------	------	------	------

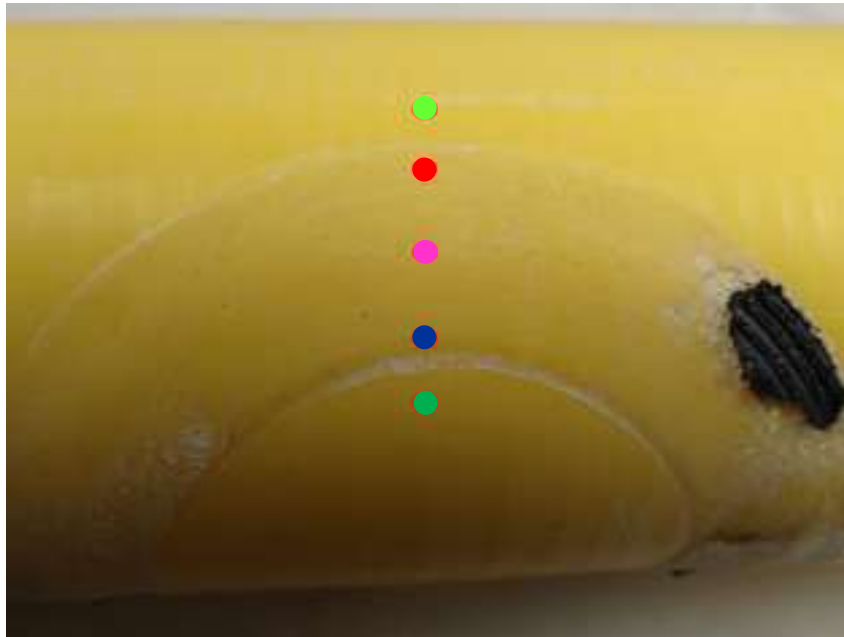

Figure 69. Sample 172318-020, decohesion test result

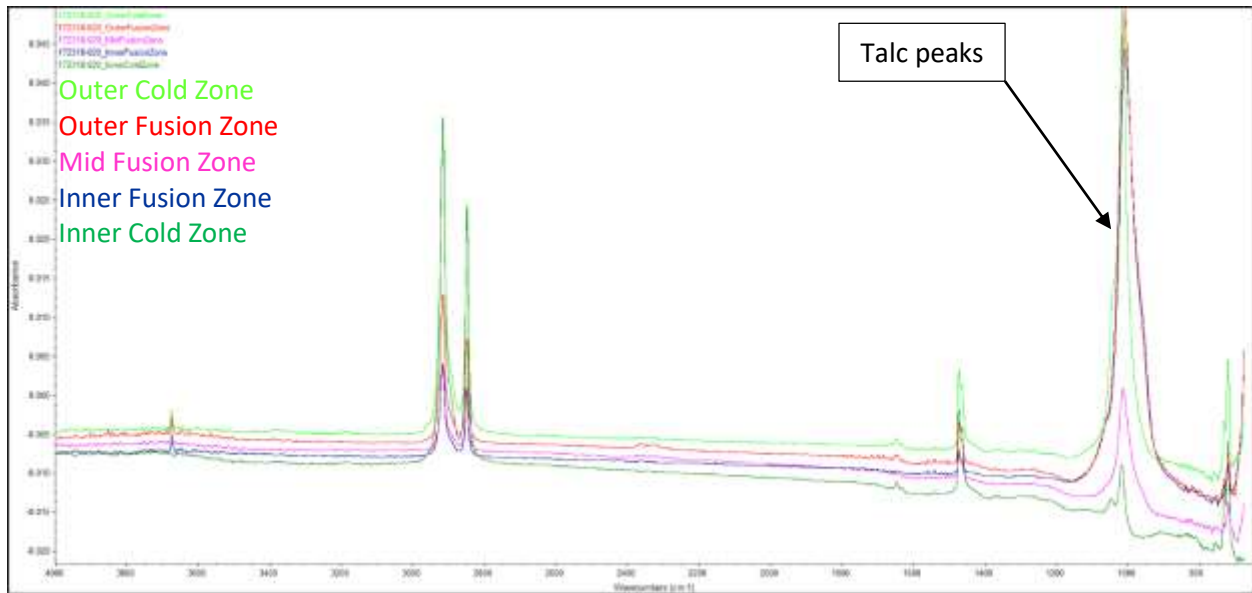

Figure 70. Sample 172318-020, FTIR spectra from decohesion test result

172318-021

172318-021	172395-041	Bentonite	99% Isopropanol	Lint-Free Wipe
------------	------------	-----------	-----------------	----------------

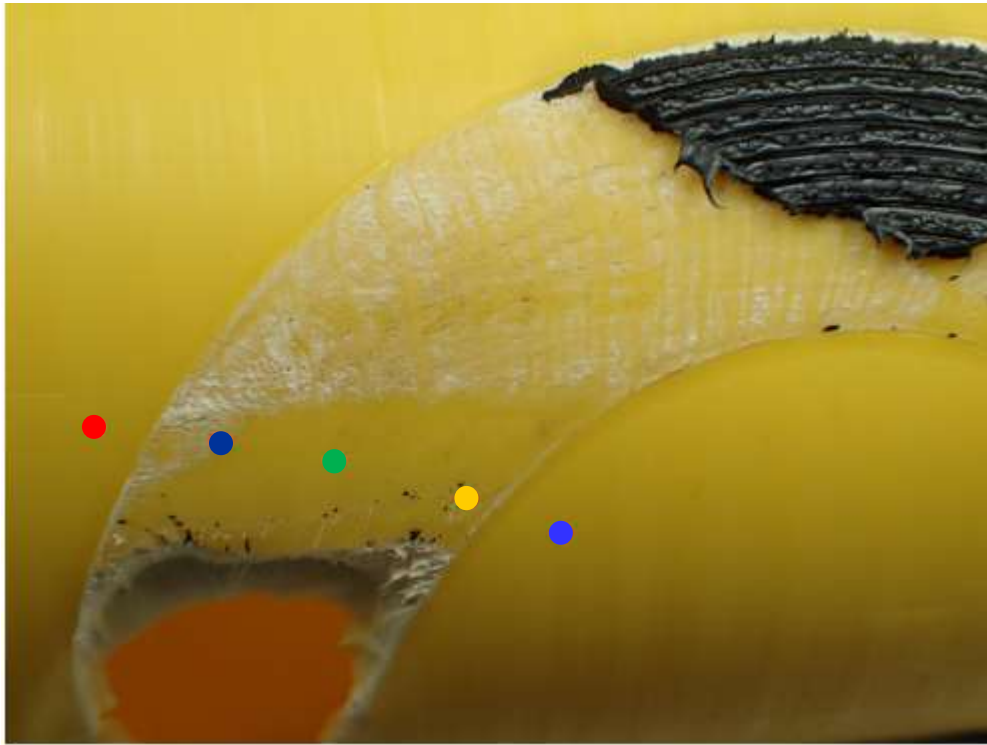

Figure 71. Sample 172318-021, decohesion test result

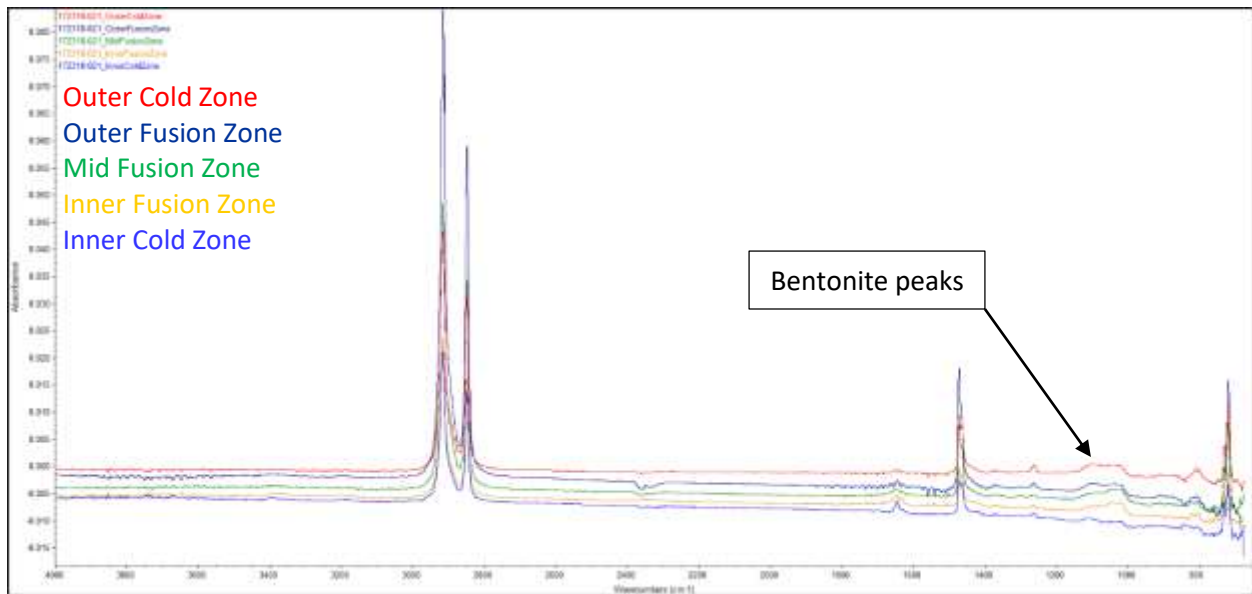

Figure 72. Sample 172318-021, FTIR spectra from decohesion test result

172318-022

172318-022	172395-042	Bentonite	99% Isopropanol	Lint-Free Wipe
------------	------------	-----------	-----------------	----------------

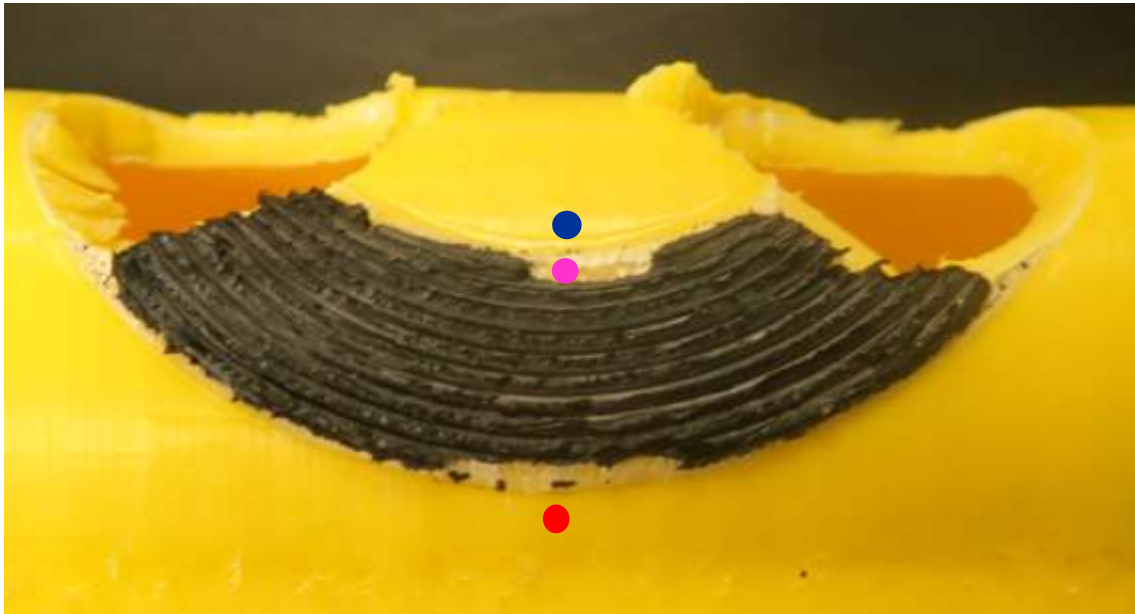

Figure 73. Sample 172318-022, decohesion test result

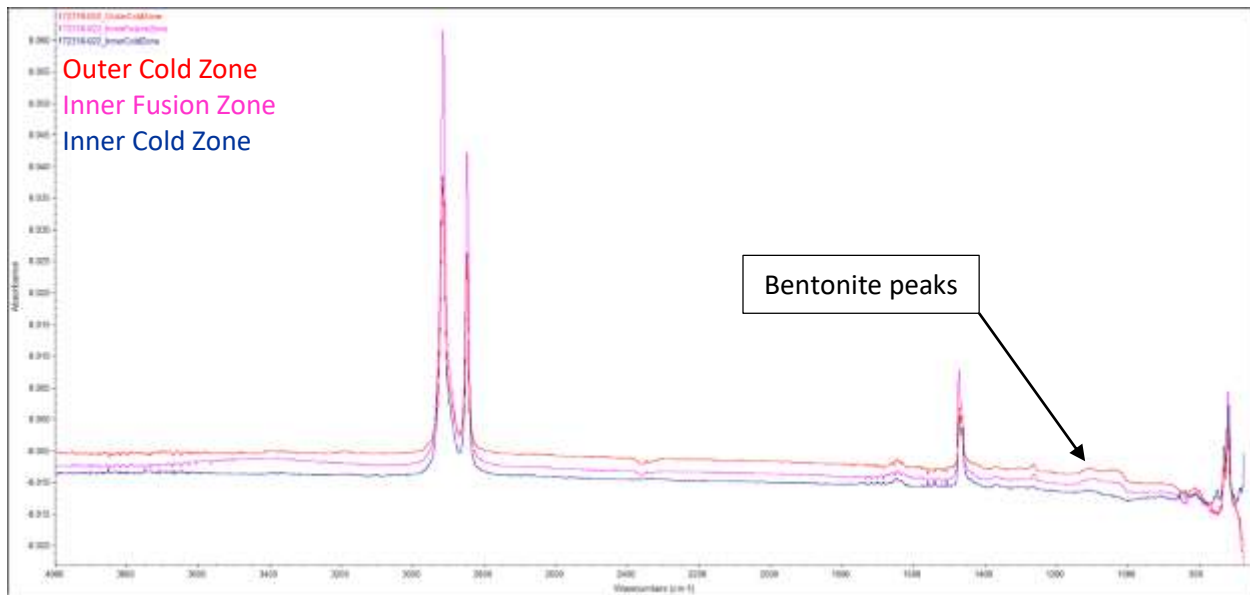

Figure 74. Sample 172318-022, FTIR spectra from decohesion test result

172318-023

172318-023	172395-045	Bentonite	99% Isopropanol	Cotton Cloth Rag
------------	------------	-----------	-----------------	------------------

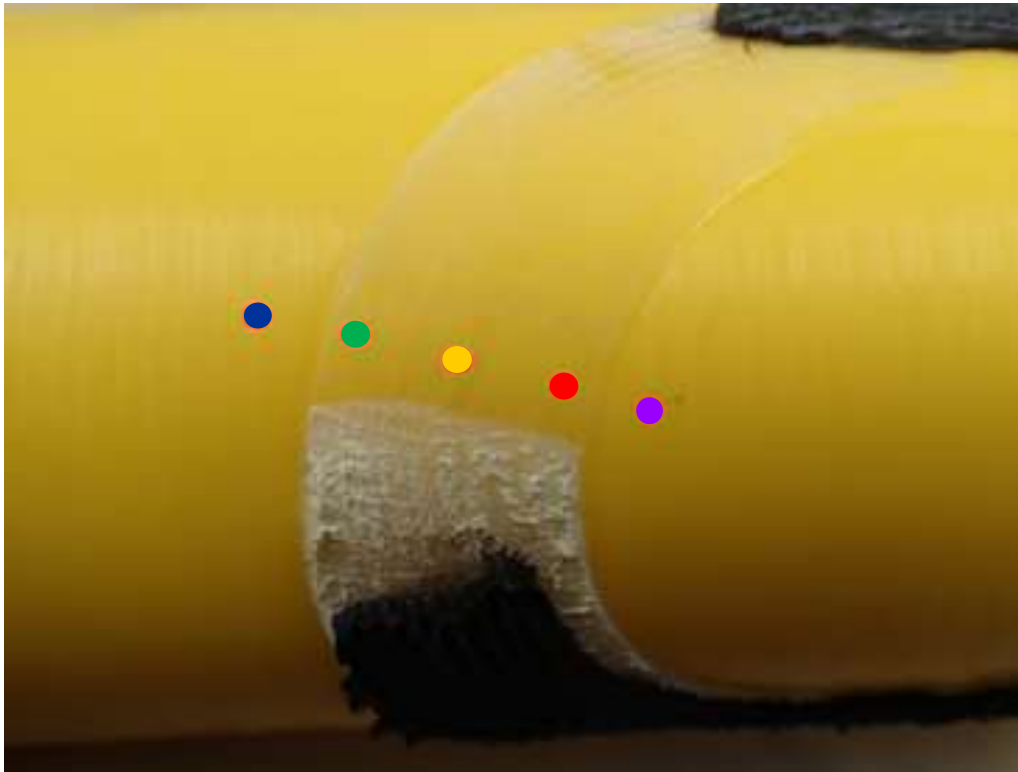

Figure 75. Sample 172318-023, decohesion test result

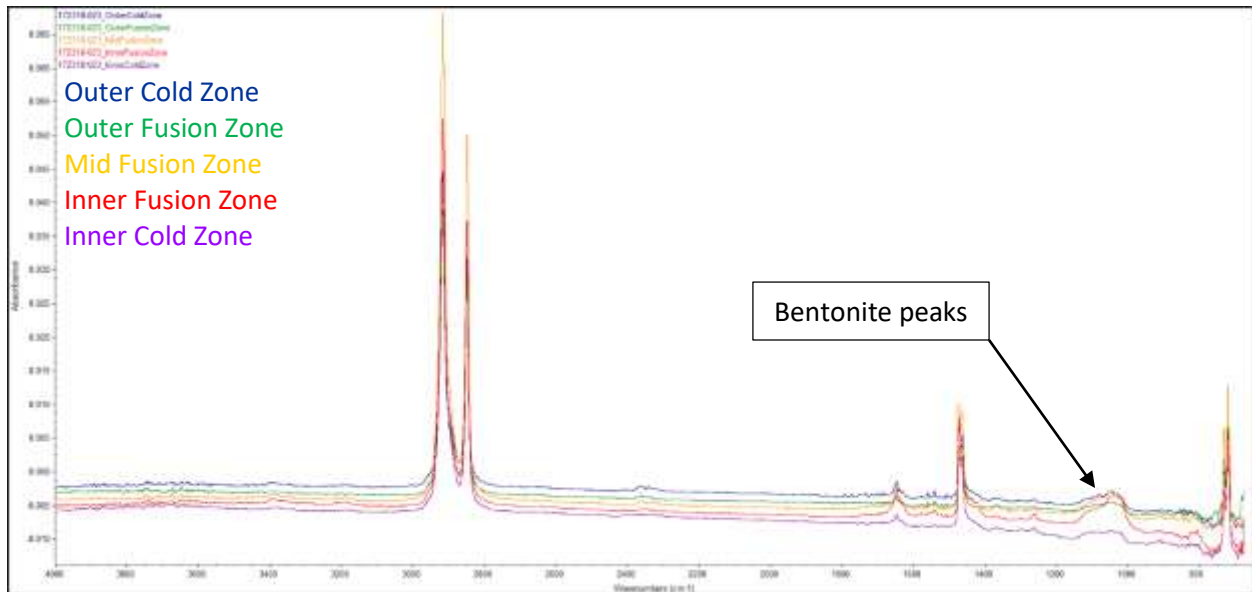

Figure 76. Sample 172318-023, FTIR spectra from decohesion test result

172318-024

172318-024	172395-046	Bentonite	99% Isopropanol	Cotton Cloth Rag
------------	------------	-----------	-----------------	------------------

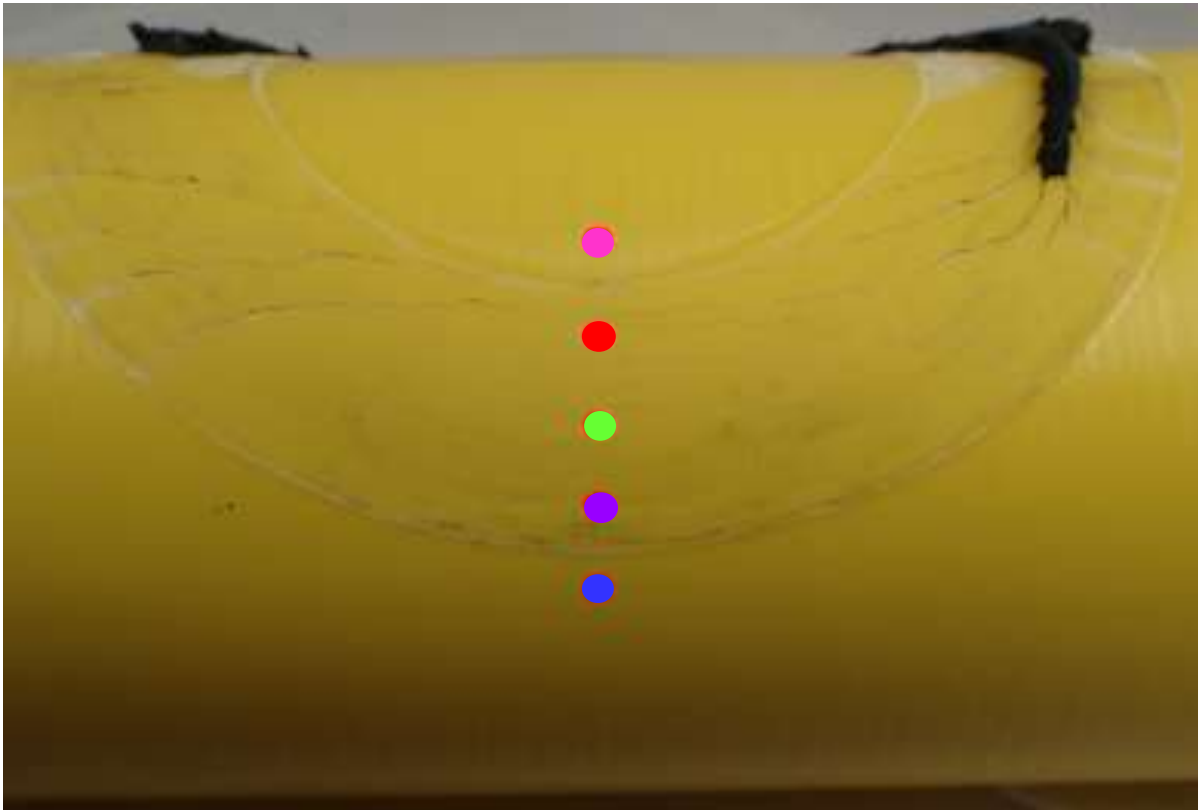

Figure 77. Sample 172318-024, decohesion test result

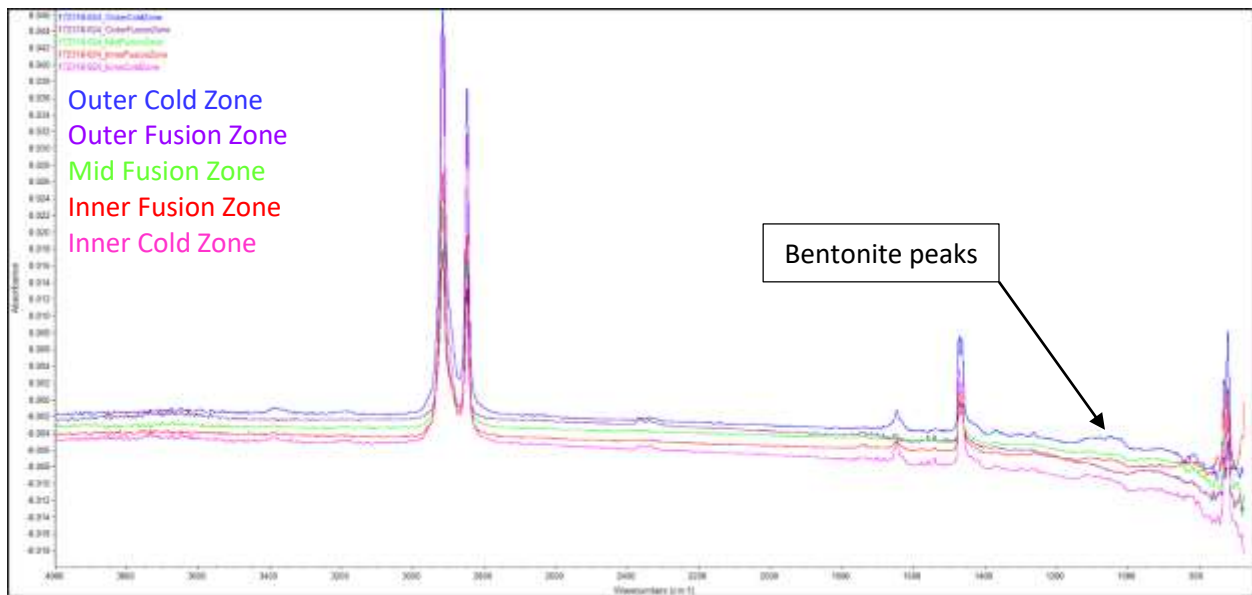

Figure 78. Sample 172318-024, FTIR spectra from decohesion test result

172318-025

172318-025	172395-049	Bentonite	99% Isopropanol	Paper Towel
------------	------------	-----------	-----------------	-------------

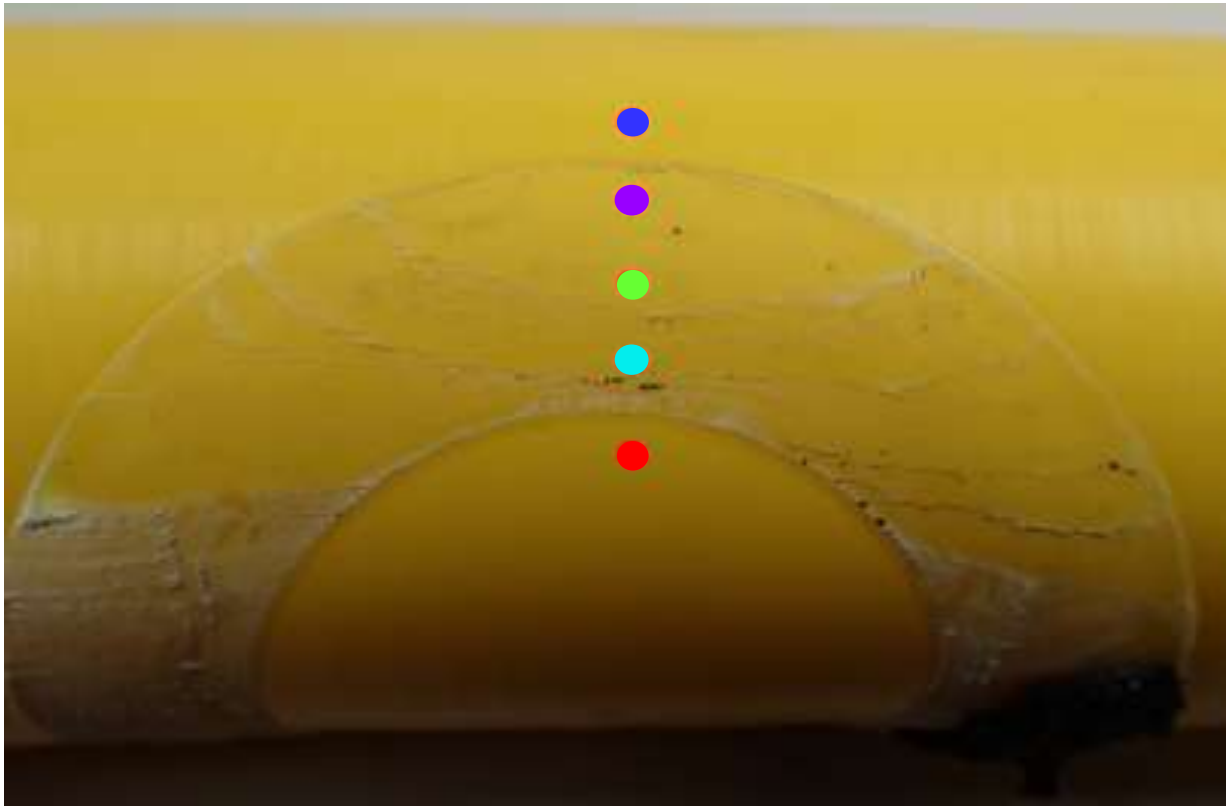

Figure 79. Sample 172318-025, decohesion test result

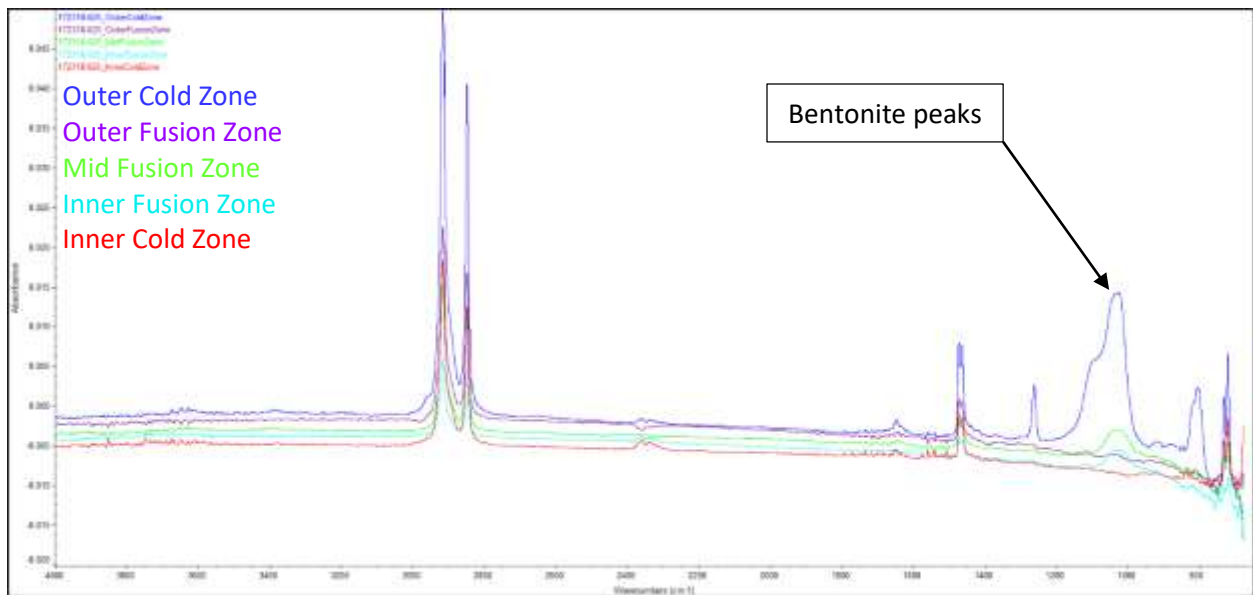

Figure 80. Sample 172318-025, FTIR spectra from decohesion test result

172318-026

172318-026	172395-050	Bentonite	99% Isopropanol	Paper Towel
------------	------------	-----------	-----------------	-------------

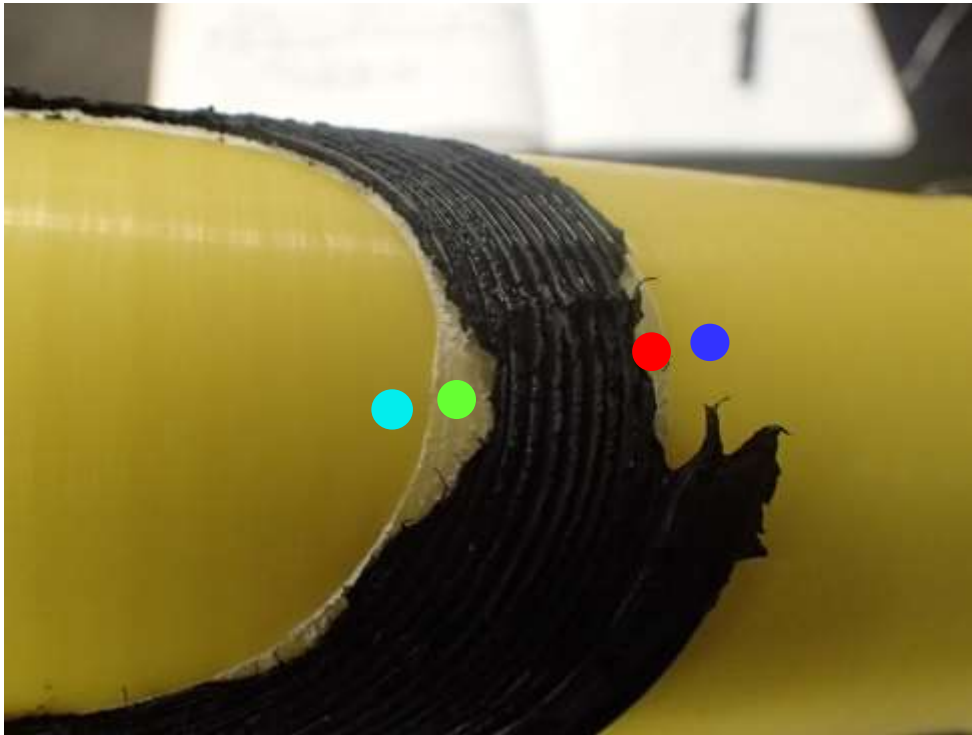

Figure 81. Sample 172318-026, decohesion test result

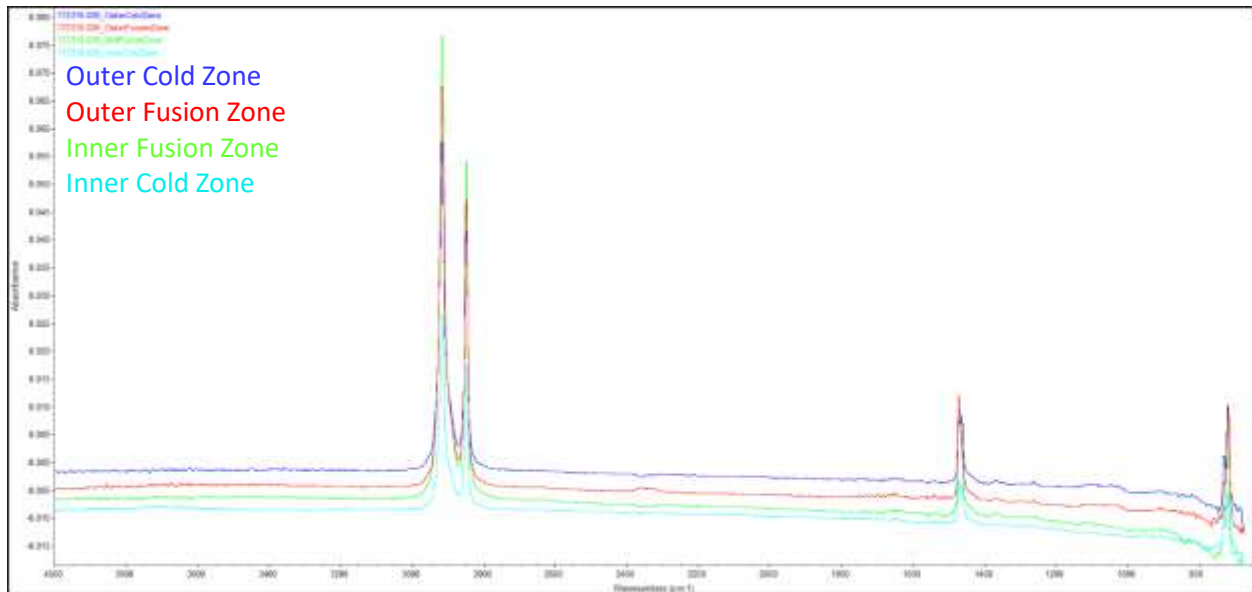

Figure 82. Sample 172318-026, FTIR spectra from decohesion test result

172318-027

172318-027	172395-053	Bentonite	91% Isopropanol	Lint-Free Wipe
------------	------------	-----------	-----------------	----------------

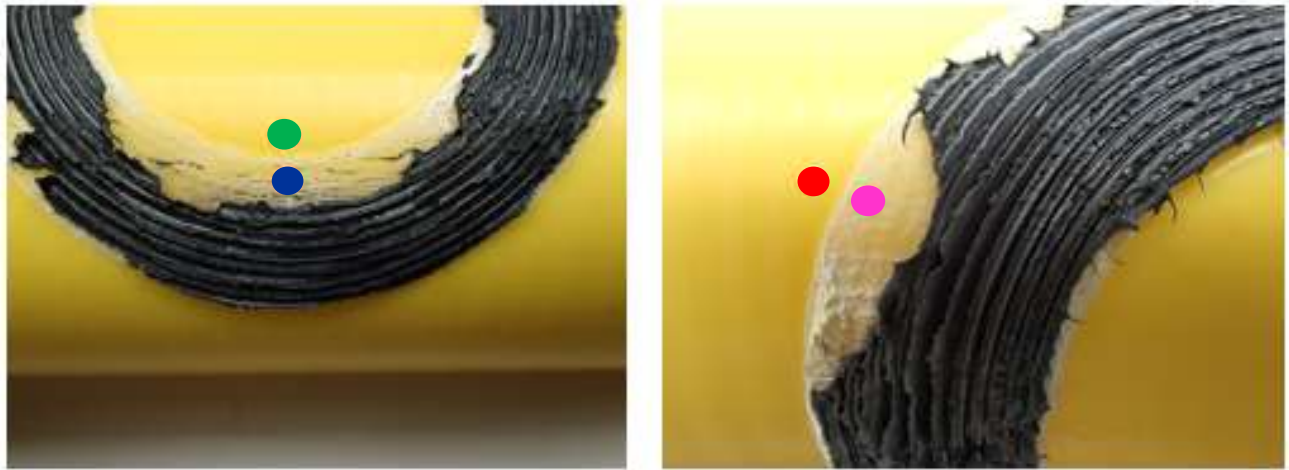

Figure 83. Sample 172318-027, decohesion test result

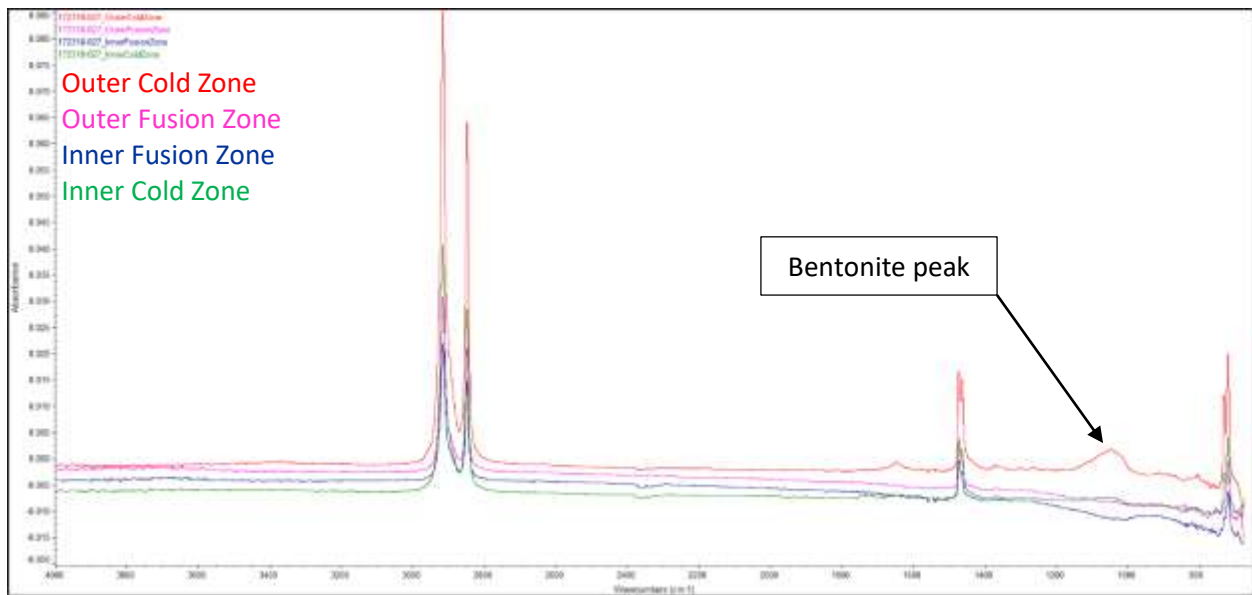

Figure 84. Sample 172318-027, FTIR spectra from decohesion test result

172318-028

172318-028	172395-054	Bentonite	91% Isopropanol	Lint-Free Wipe
------------	------------	-----------	-----------------	----------------

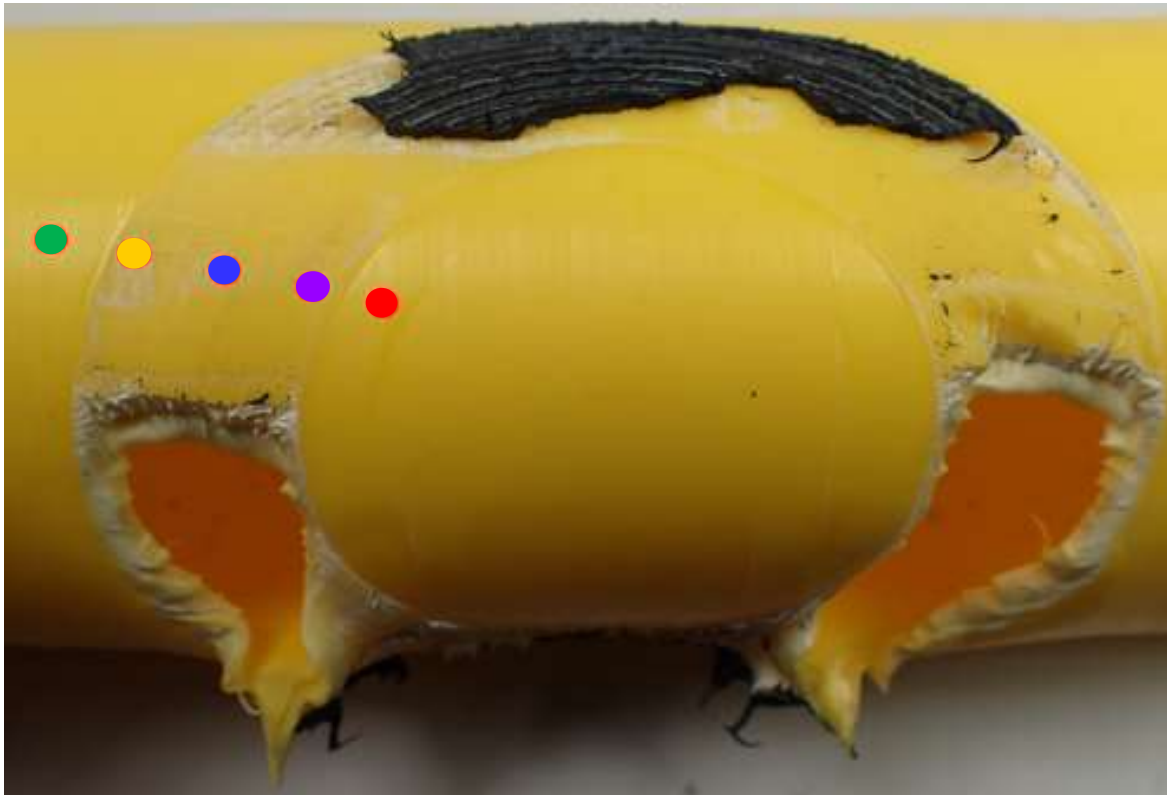

Figure 85. Sample 172318-028, decohesion test result

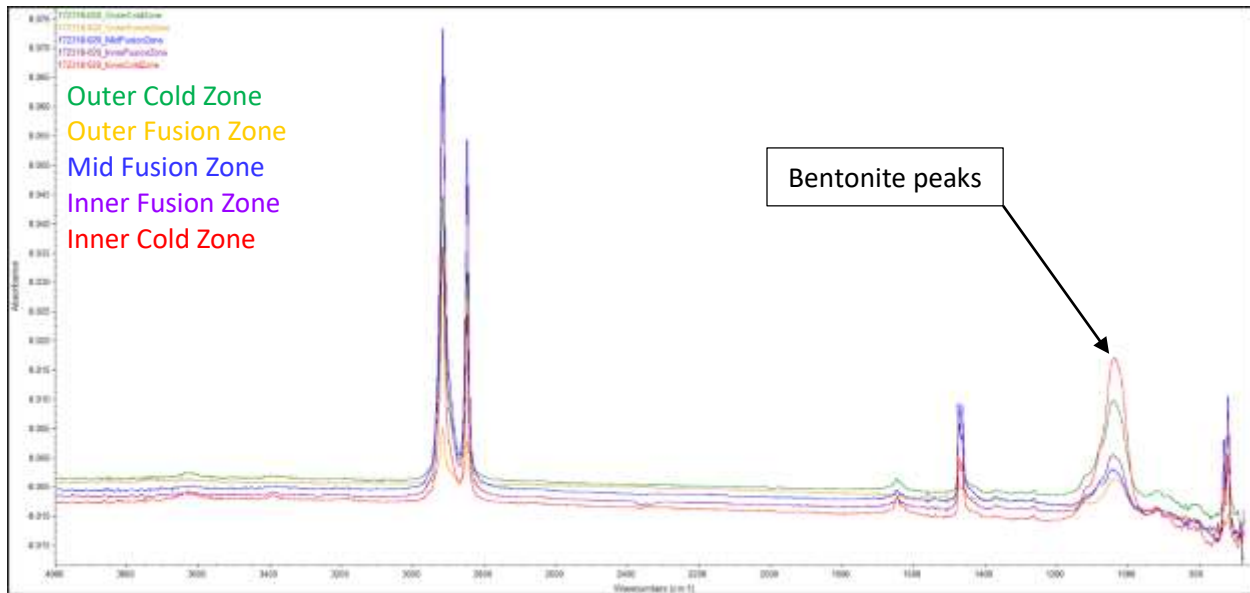

Figure 86. Sample 172318-028, FTIR spectra from decohesion test result

172318-029

172318-029	172395-057	Bentonite	91% Isopropanol	Cotton Cloth Rag
------------	------------	-----------	-----------------	------------------

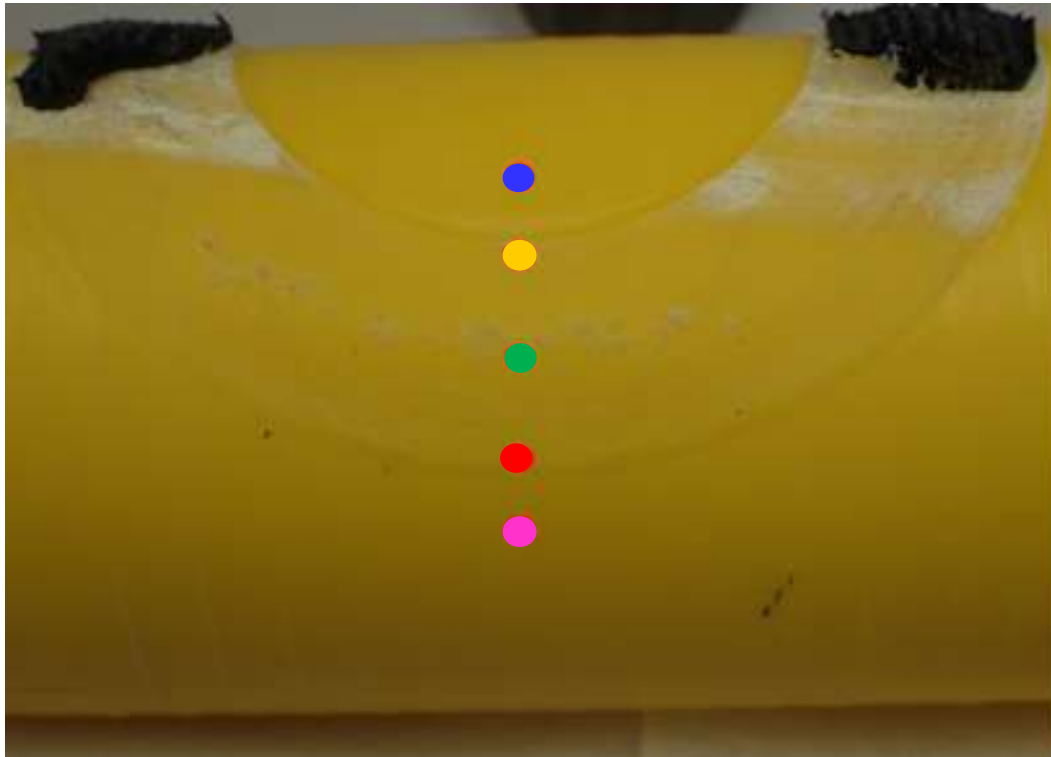

Figure 87. Sample 172318-029, decohesion test result

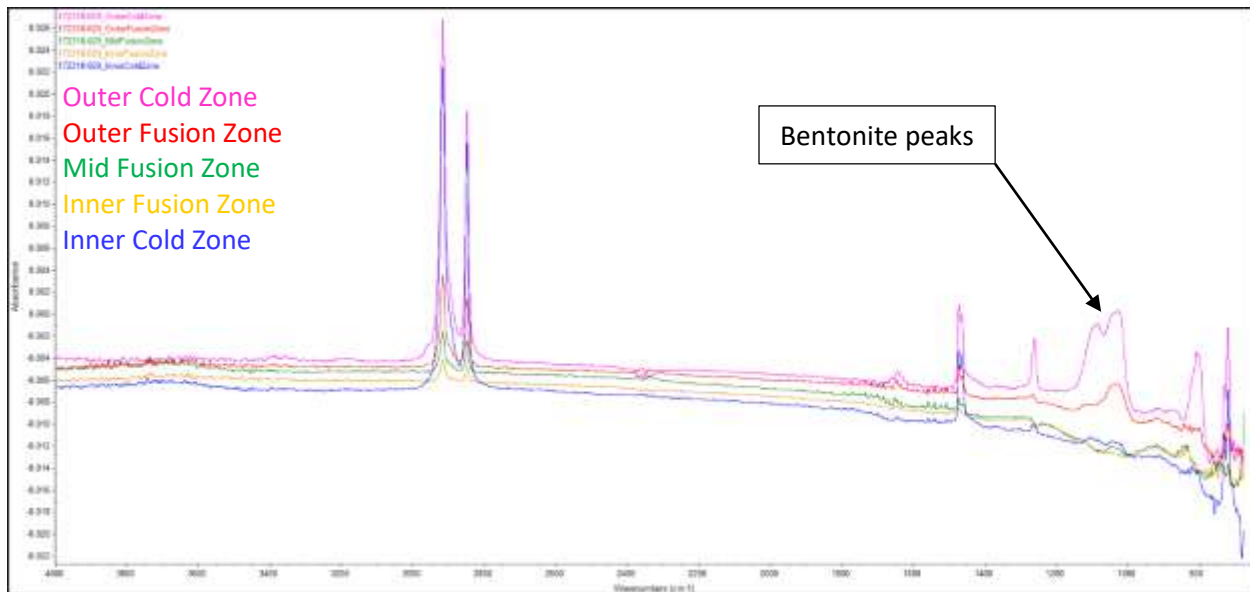

Figure 88. Sample 172318-029, FTIR spectra from decohesion test result

172318-031

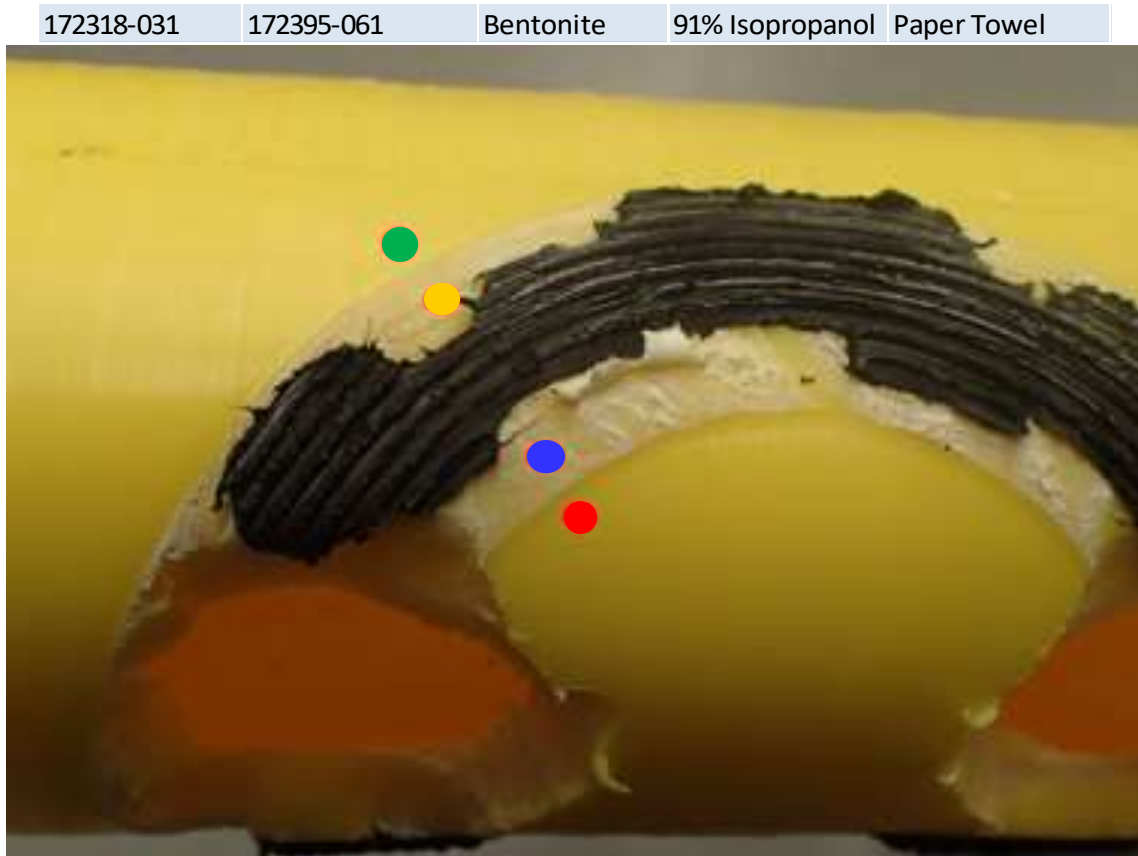

Figure 89. Sample 172318-031, decohesion test result

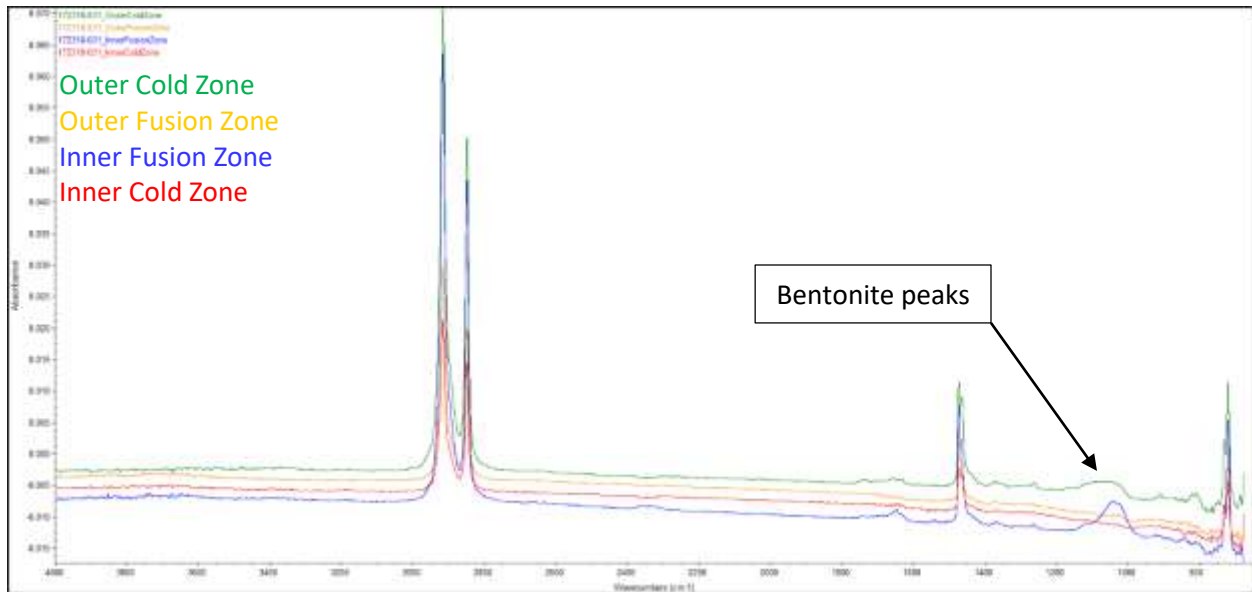

Figure 90. Sample 172318-031, FTIR spectra from decohesion test result

172318-033

172318-033	172395-065	Bentonite	Acetone	Lint-Free Wipe
------------	------------	-----------	---------	----------------

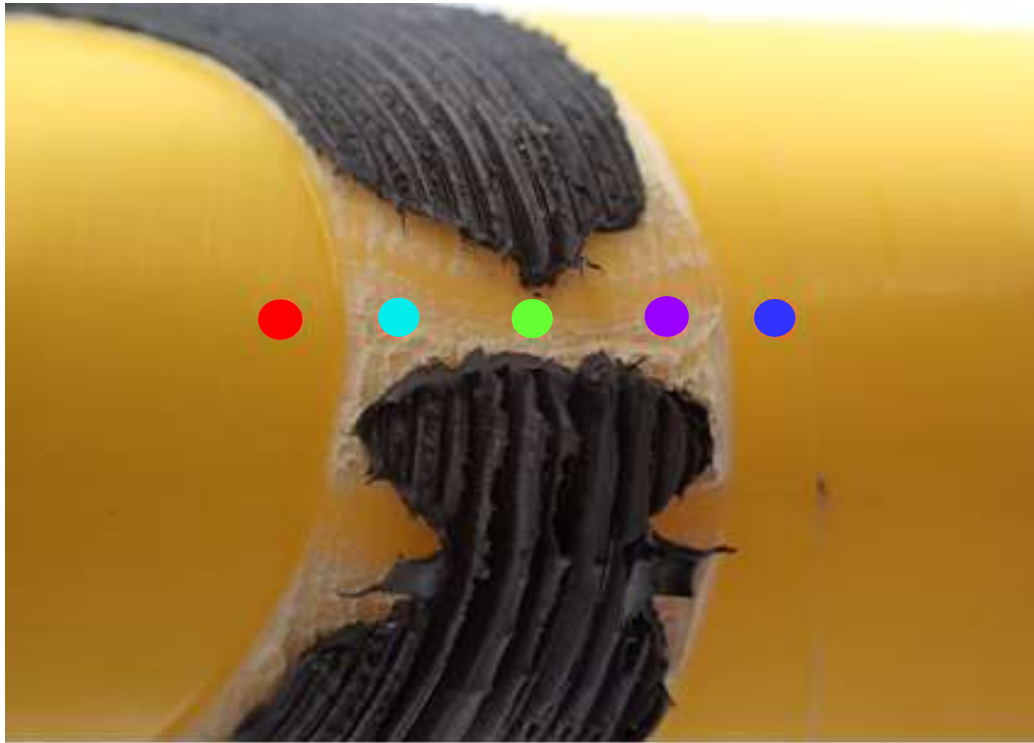

Figure 91. Sample 172318-033, decohesion test result

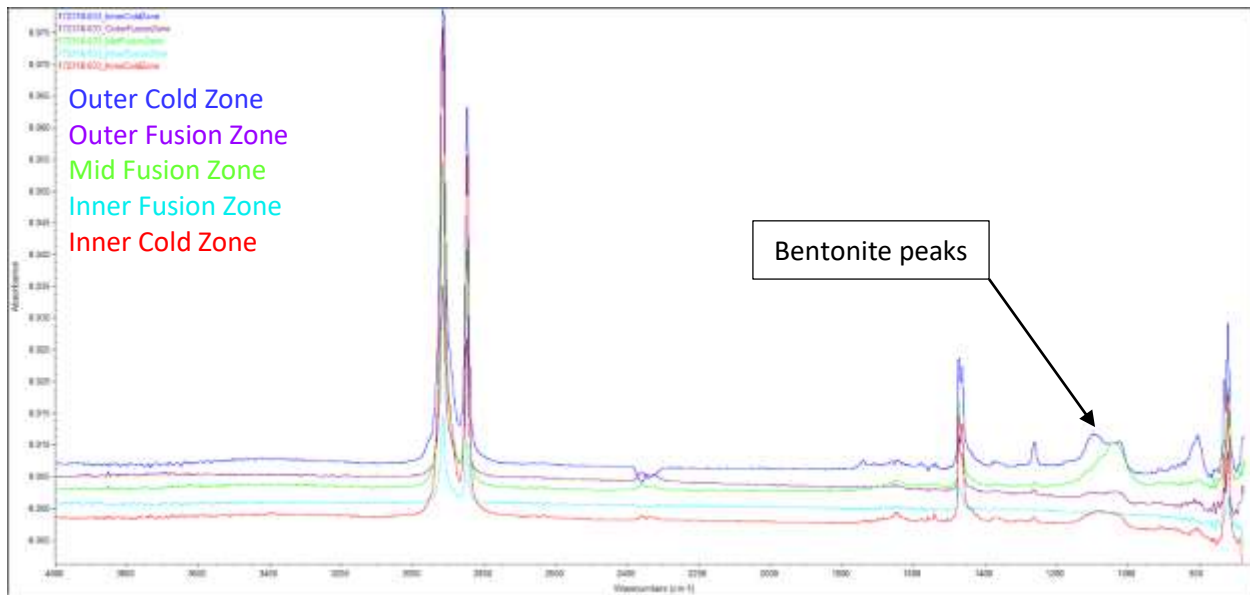

Figure 92: Sample 172318-033, FTIR spectra from decohesion test result

172318-034

172318-034	172395-066	Bentonite	Acetone	Lint-Free Wipe
------------	------------	-----------	---------	----------------

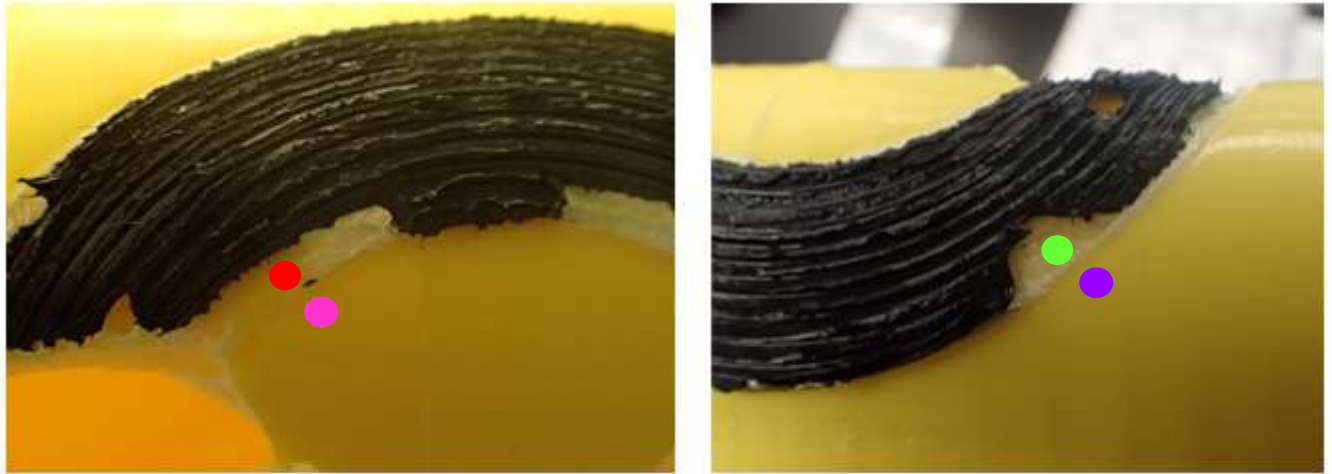

Figure 93. Sample 172318-034, decohesion test result

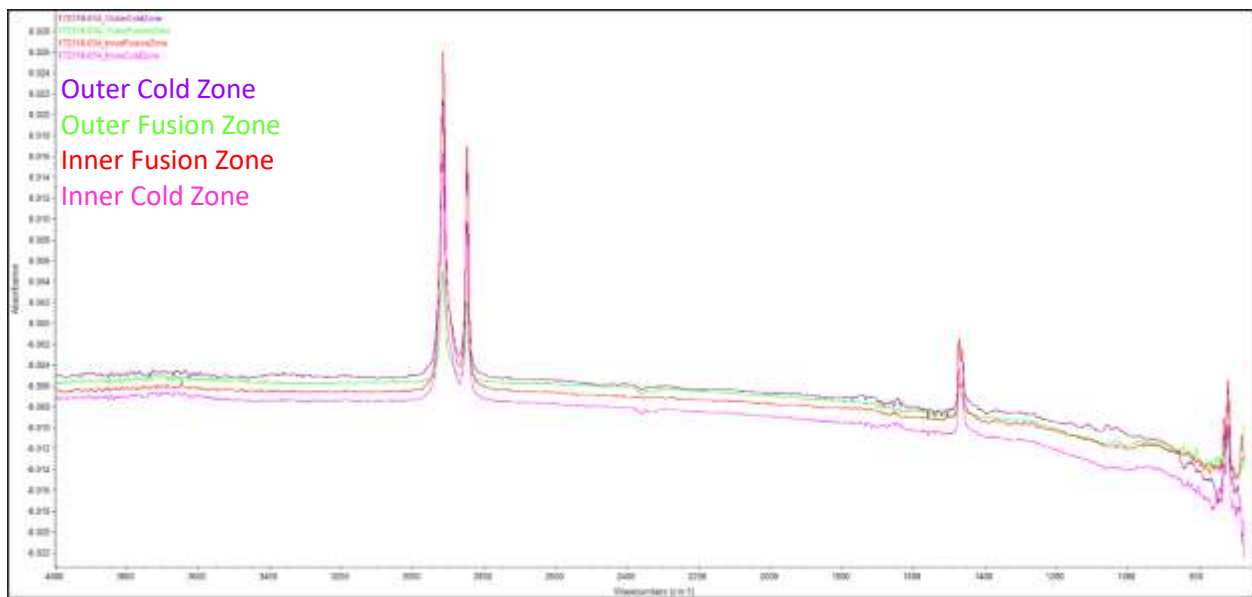

Figure 94. Sample 172318-034, FTIR spectra from decohesion test result

172318-035

172318-035	172395-069	Bentonite	Acetone	Cotton Cloth Rag
------------	------------	-----------	---------	------------------

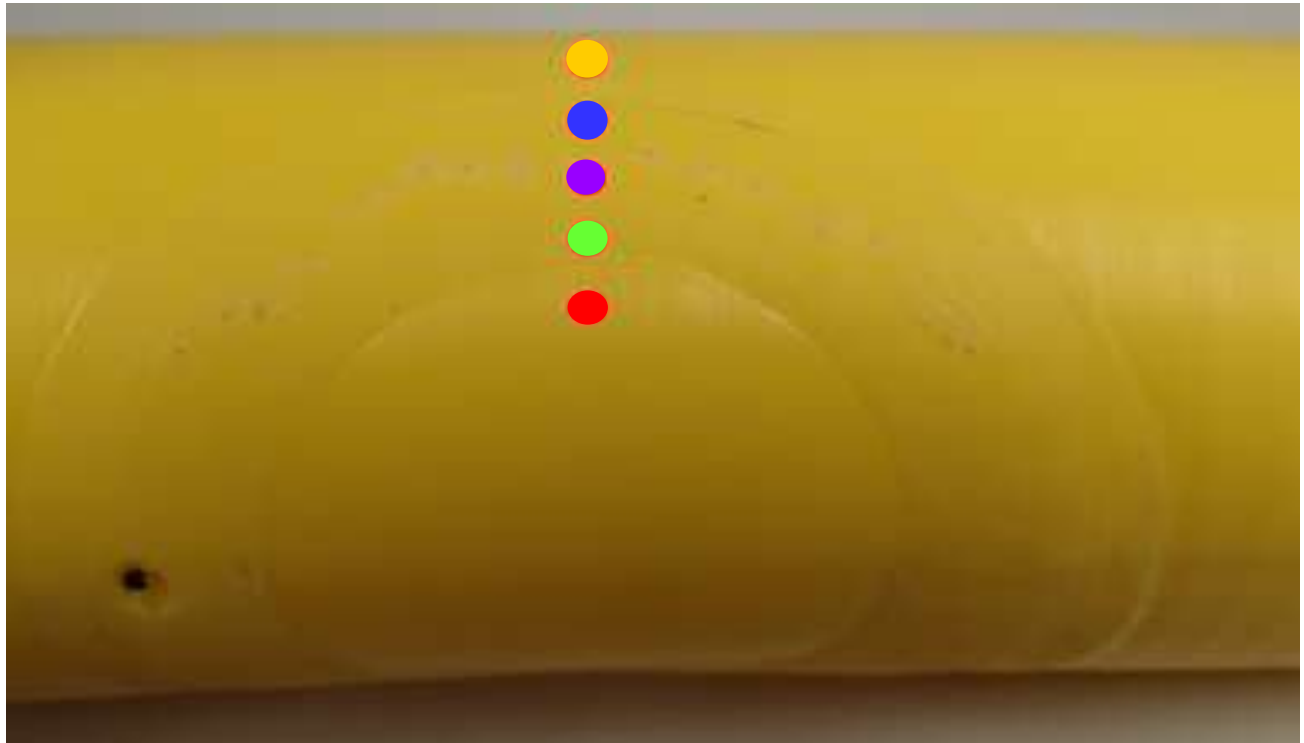

Figure 95. Sample 172318-035, decohesion test result

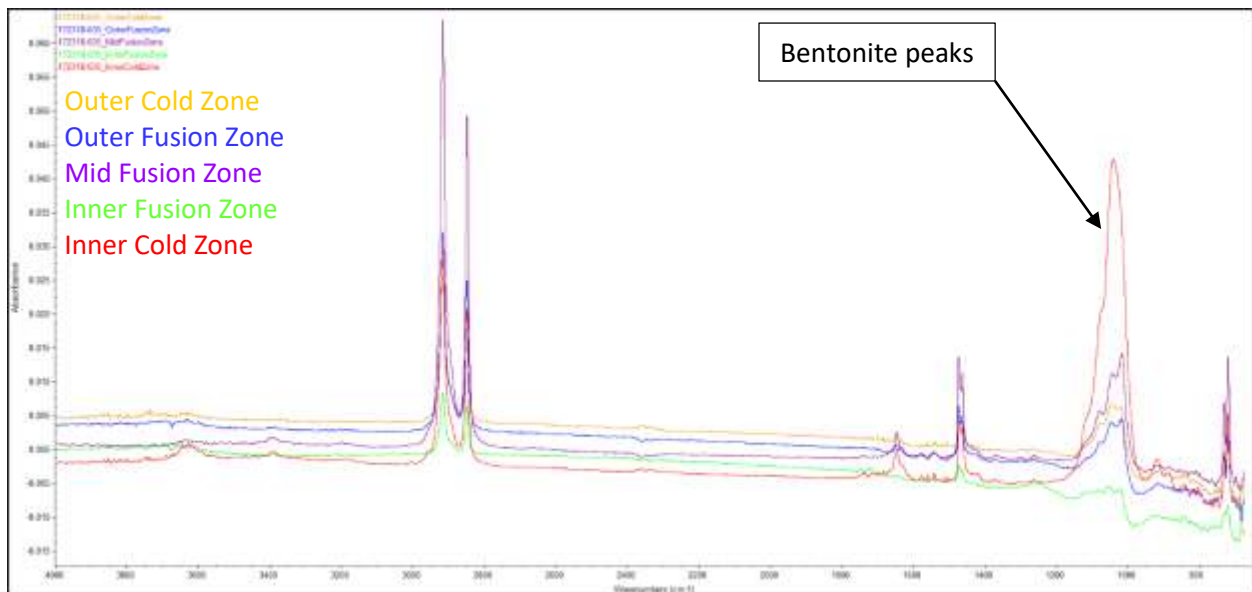

Figure 96. Sample 172318-035, FTIR spectra from decohesion test result

172318-036

172318-036	172395-070	Bentonite	Acetone	Cotton Cloth Rag
------------	------------	-----------	---------	------------------

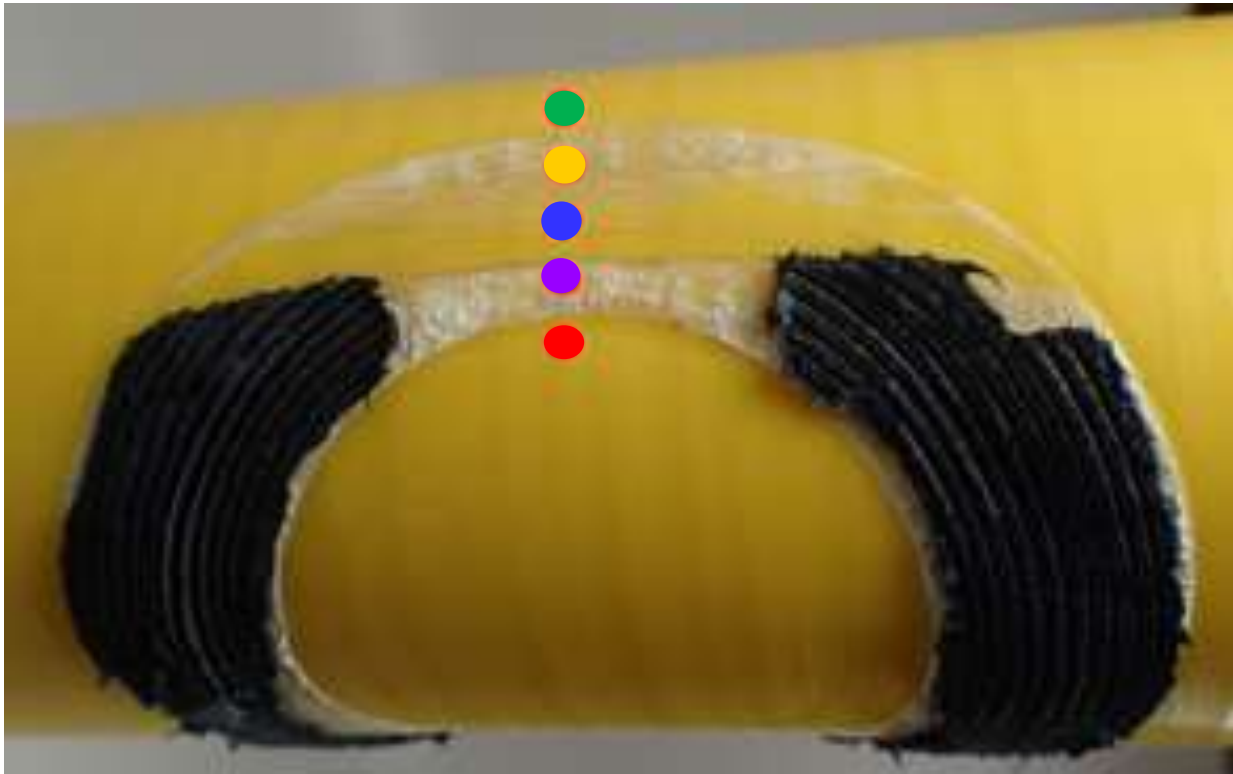

Figure 97. Sample 172318-036, decohesion test result

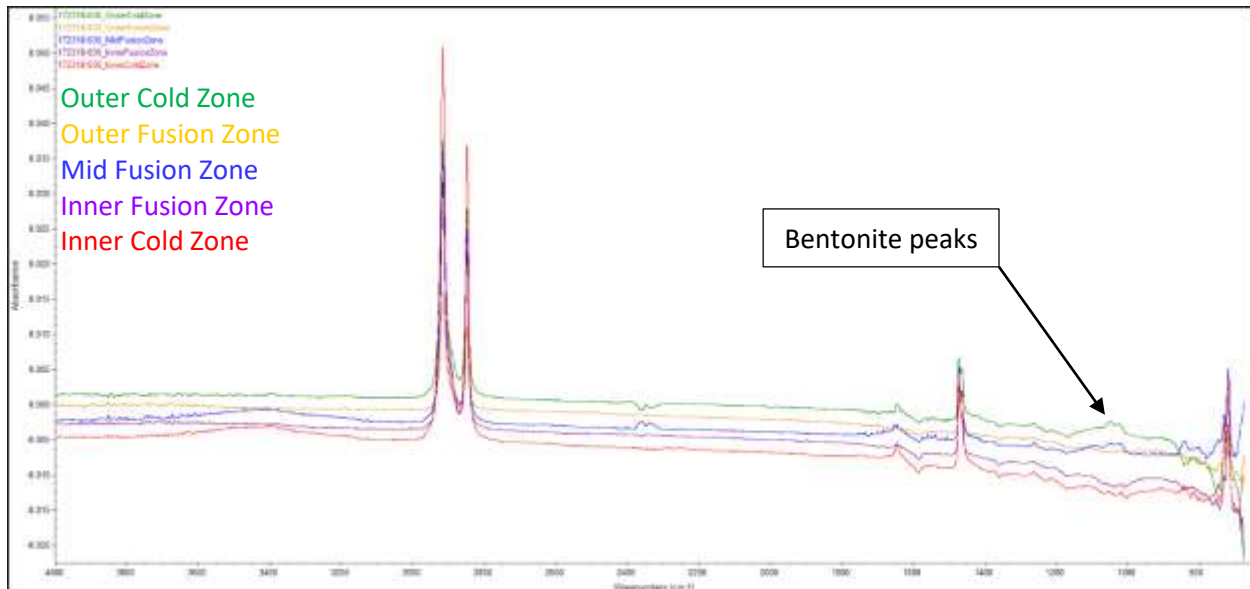

Figure 98. Sample 172318-036, FTIR spectra from decohesion test result

172318-037

172318-037	172395-073	Bentonite	Acetone	Paper Towel
------------	------------	-----------	---------	-------------

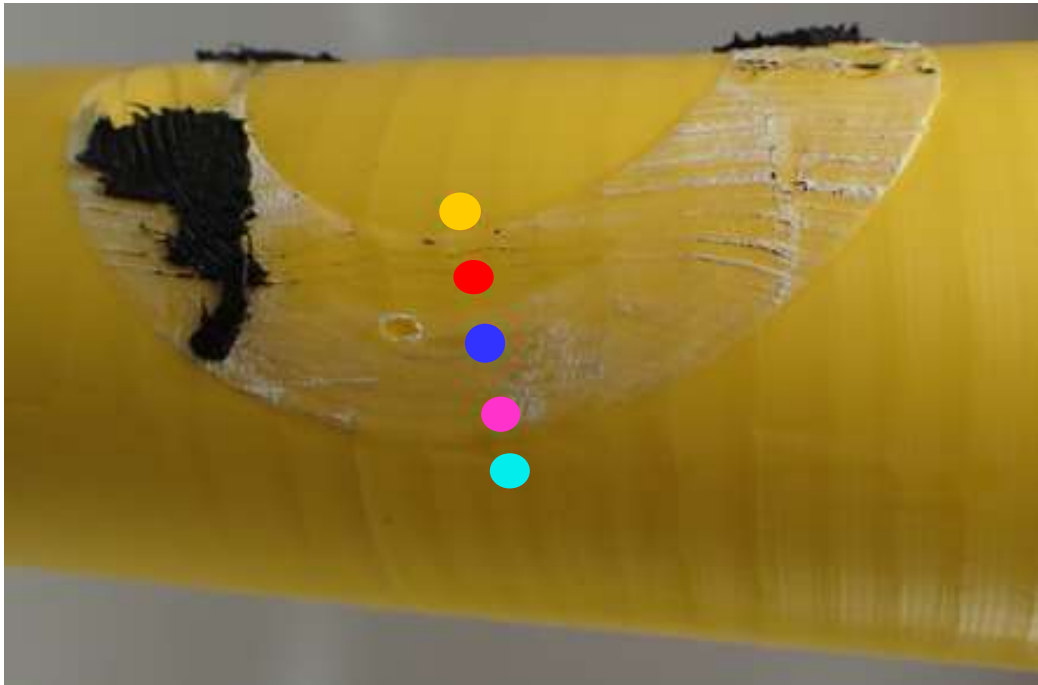

Figure 99. Sample 172318-037, decohesion test result

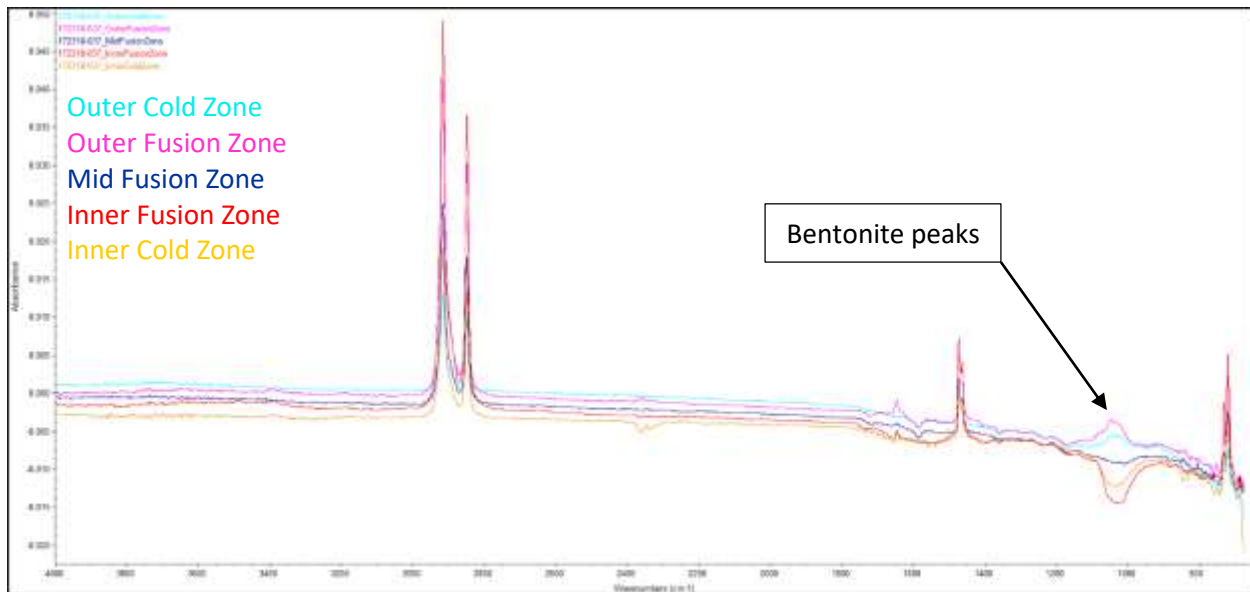

Figure 100. Sample 172318-037, FTIR spectra from decohesion test result

172318-038

172318-038	172395-074	Bentonite	Acetone	Paper Towel
------------	------------	-----------	---------	-------------

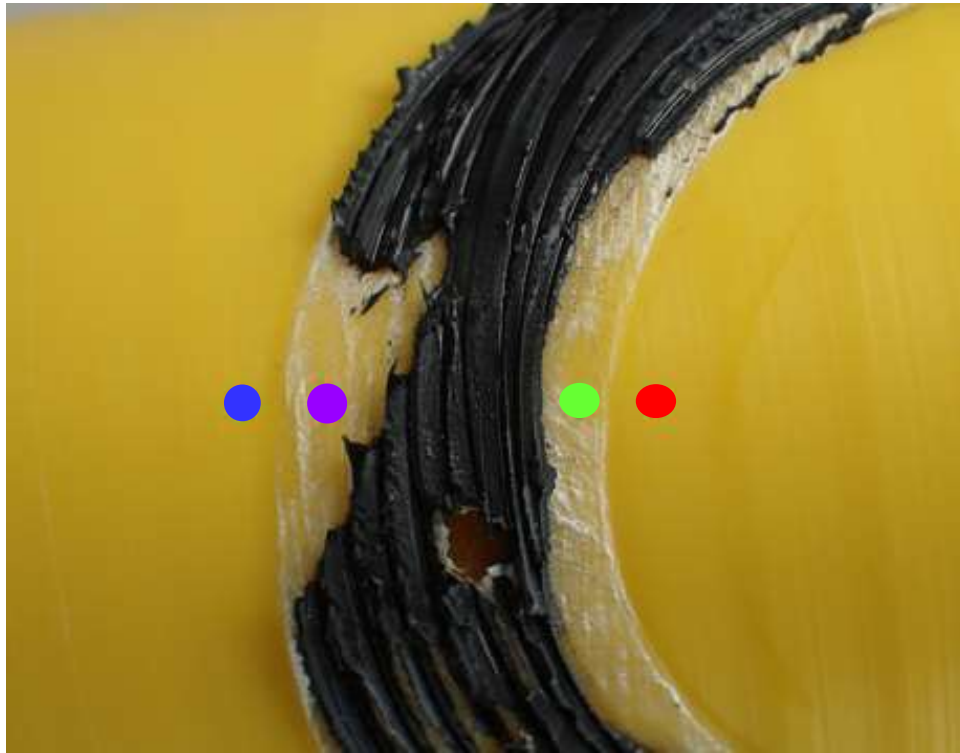

Figure 101. Sample 172318-038, decohesion test result

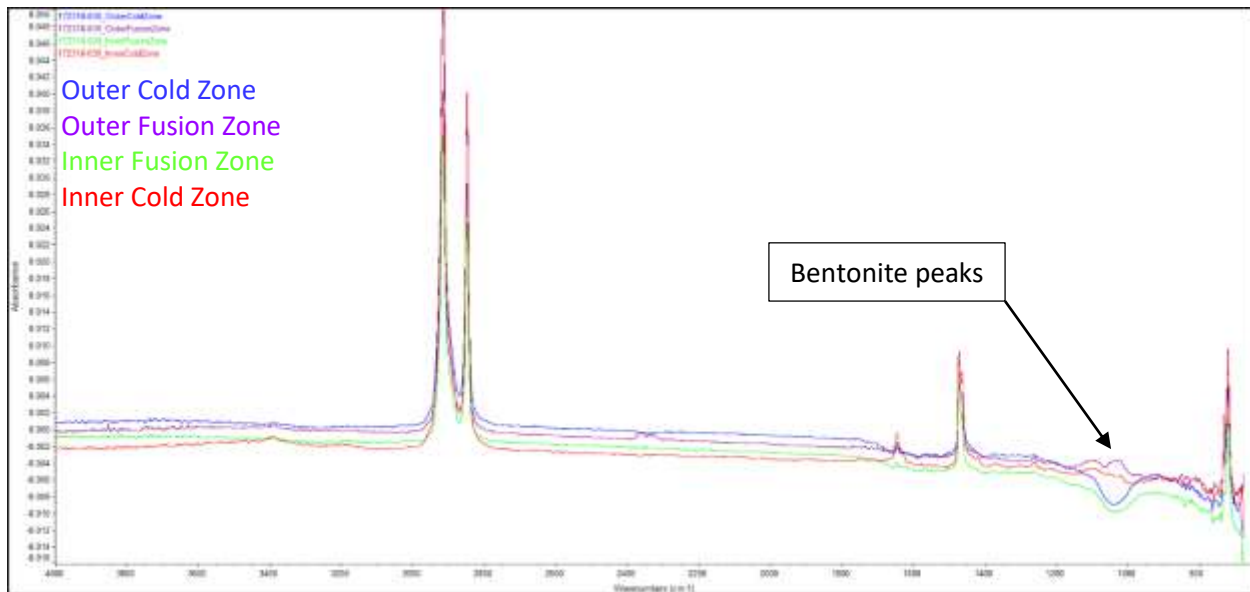

Figure 102. Sample 172318-038, FTIR spectra from decohesion test result

172318-039

172318-039	172395-077	Bentonite	None	None
------------	------------	-----------	------	------

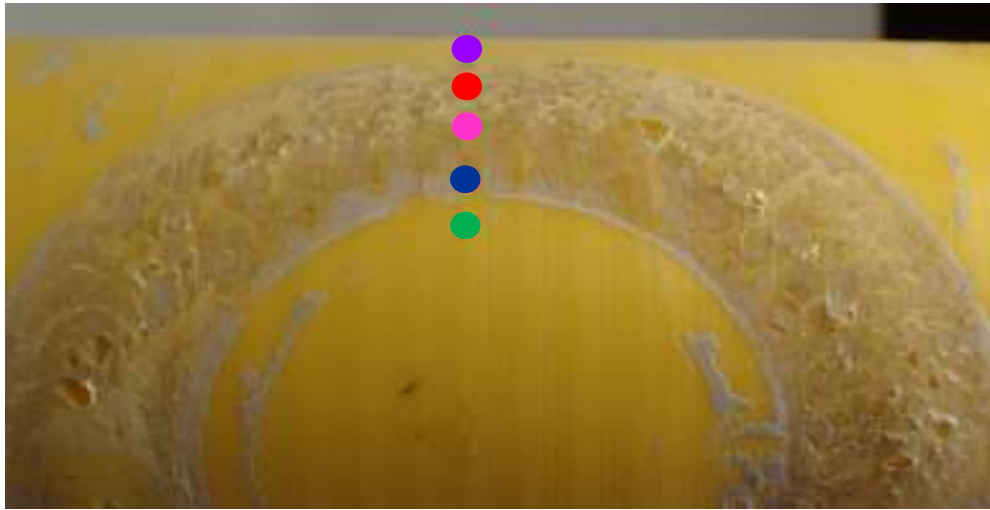

Figure 103. Sample 172318-039, decohesion test result

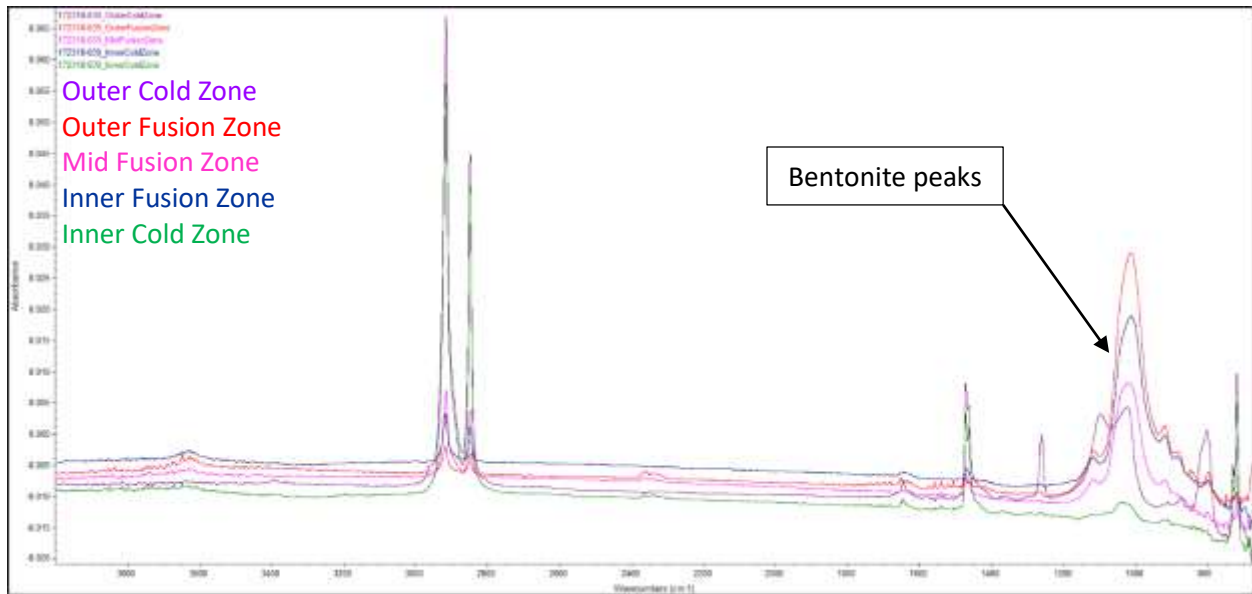

Figure 104. Sample 172318-039, FTIR spectra from decohesion test result

172318-040

172318-040	172395-078	Bentonite	None	None
------------	------------	-----------	------	------

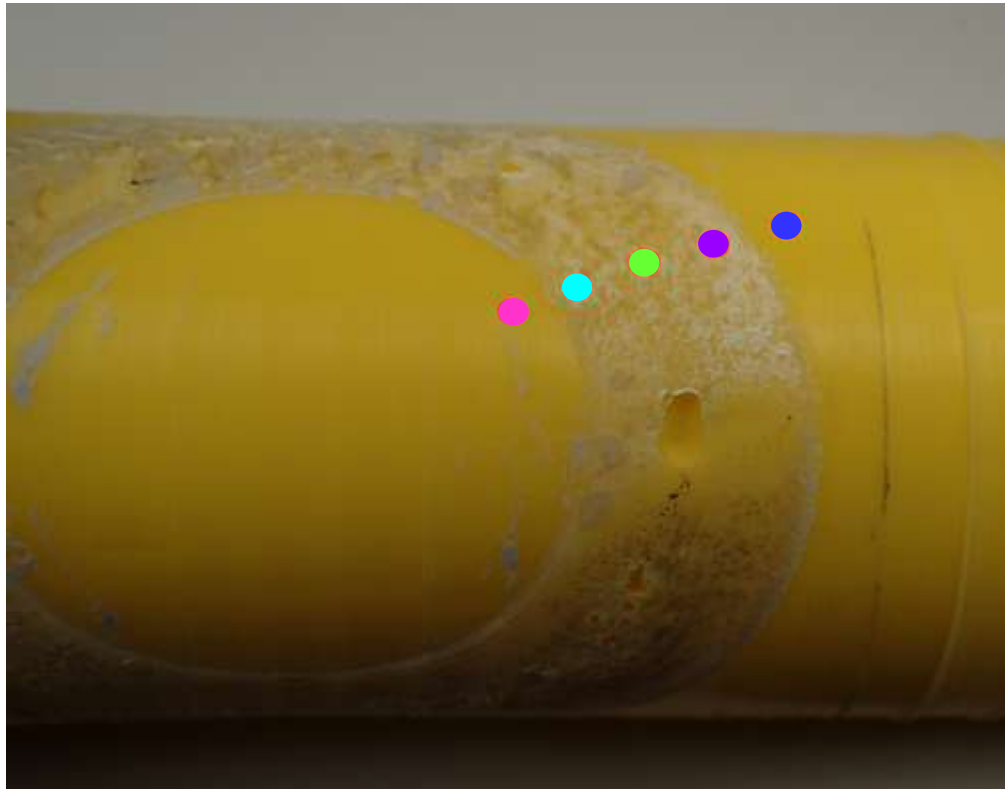

Figure 105. Sample 172318-040, decohesion test result

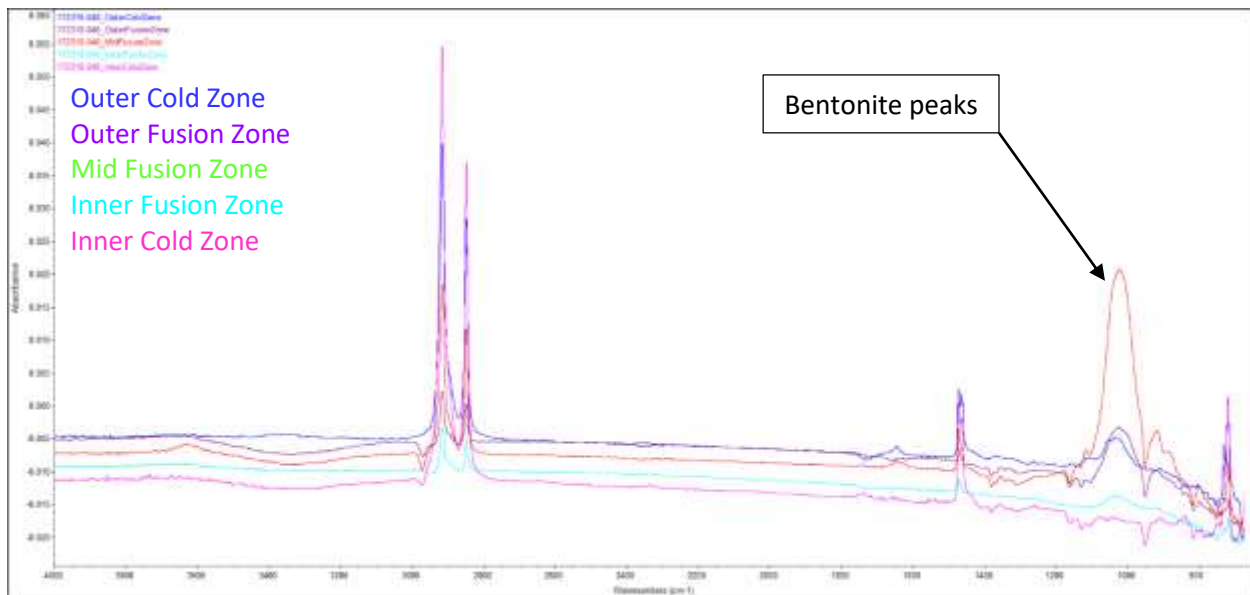

Figure 106. Sample 172318-040, FTIR spectra from decohesion test result

172318-041

172318-041 172395-081 Silicon Grease 99% Isopropanol Lint-Free Wipe

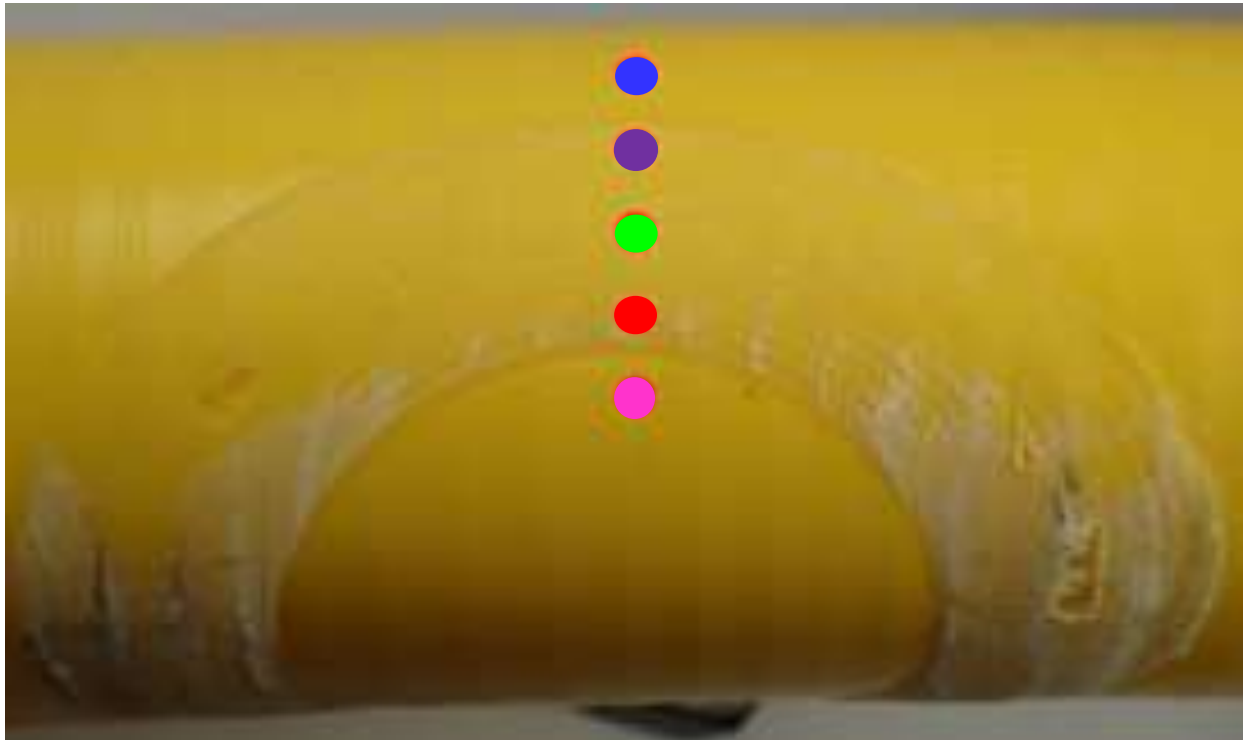

Figure 107. Sample 172318-041, decohesion test result

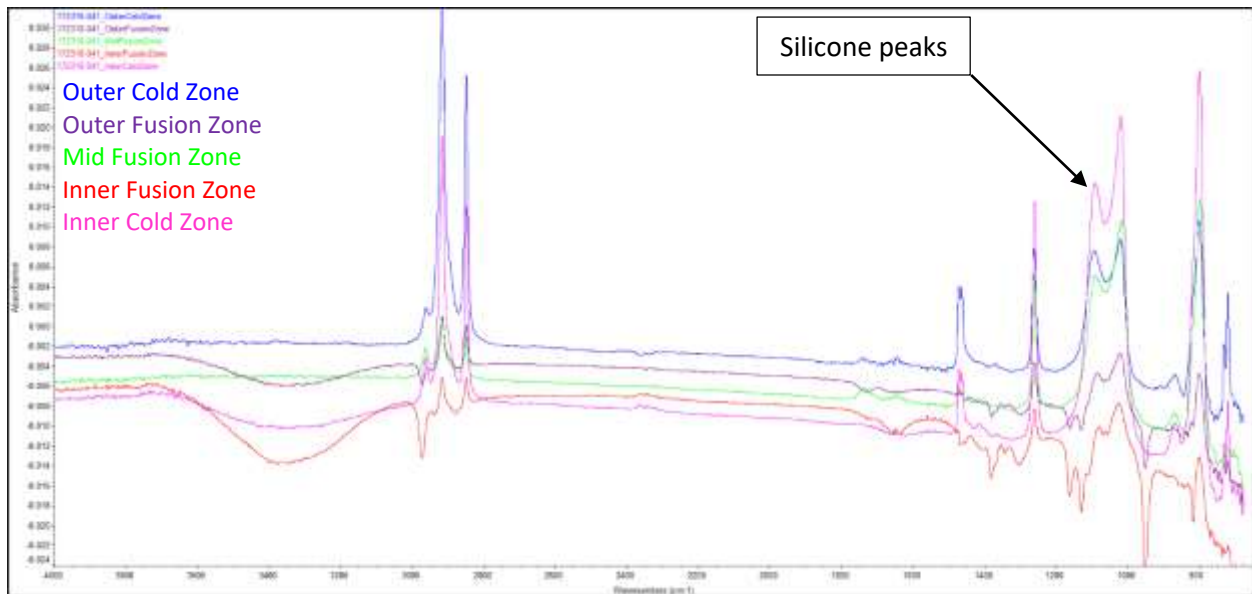

Figure 108. Sample 172318-041, FTIR spectra from decohesion test result

172318-042

172318-042 172395-082 Silicon Grease 99% Isopropanol Lint-Free Wipe



Figure 109. Sample 172318-042, decohesion test result

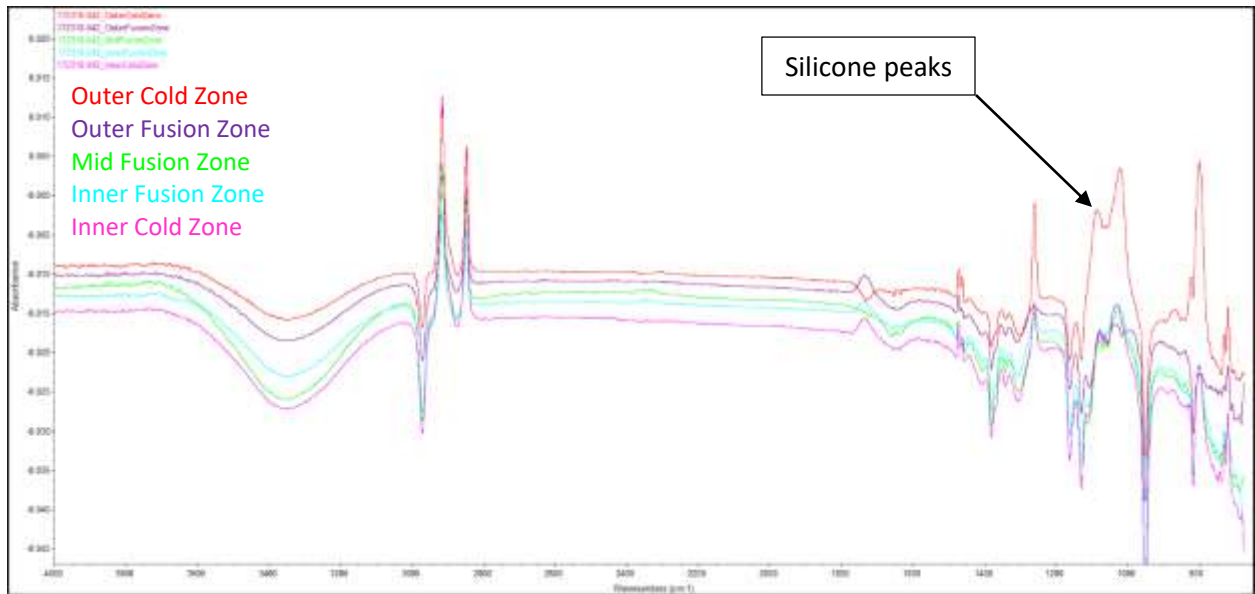

Figure 110. Sample 172318-042, FTIR spectra from decohesion test result

172318-042A

172318-042A 172395-082A Silicon Grease 99% Isopropanol Lint-Free Wipe

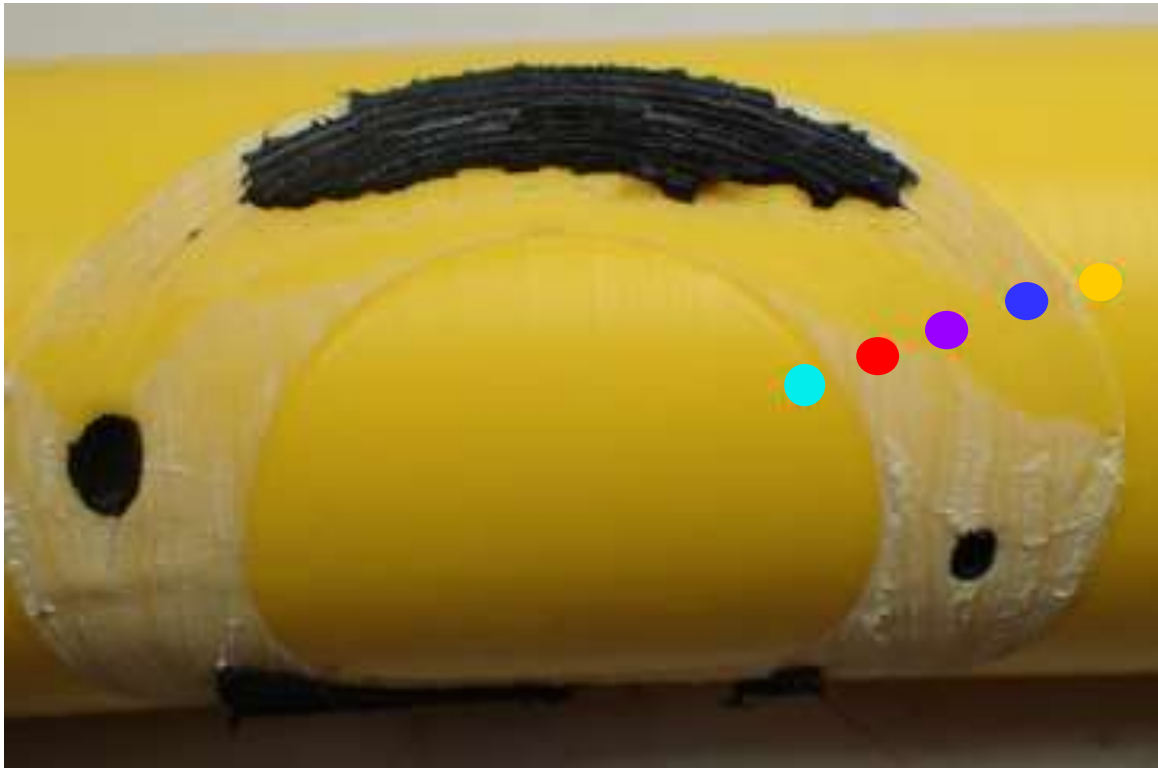

Figure 111. Sample 172318-042A, decohesion test result

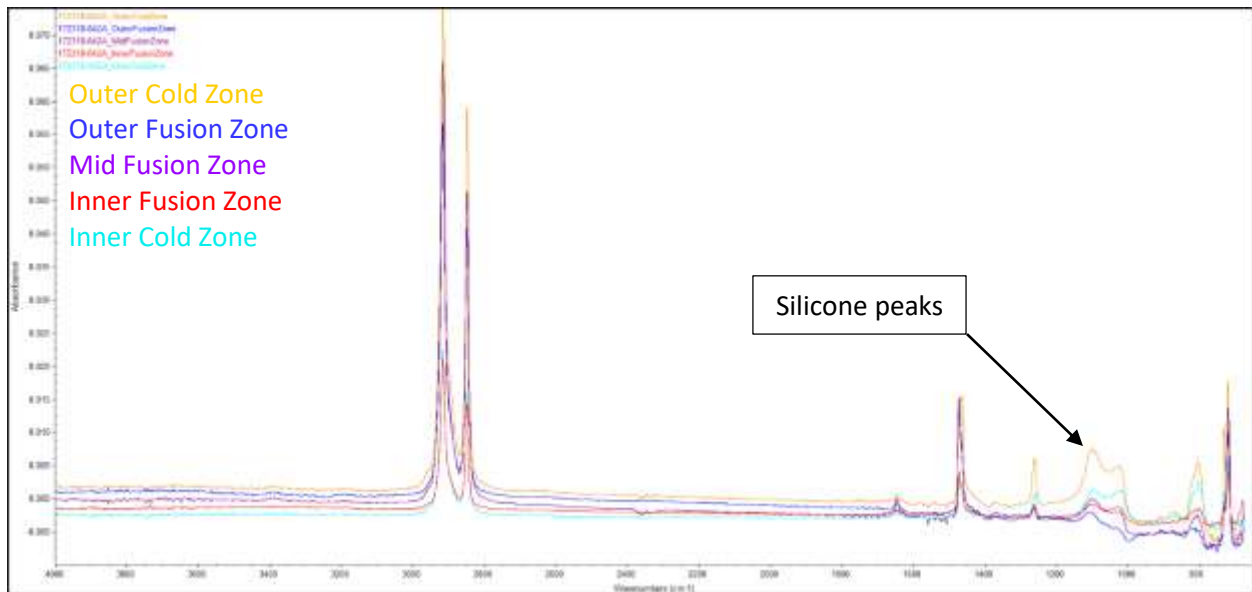

Figure 112. Sample 172318-042A, FTIR spectra from decohesion test result

172318-043

172318-043 172395-085 Silicon Grease 99% Isopropanol Cotton Cloth Rag

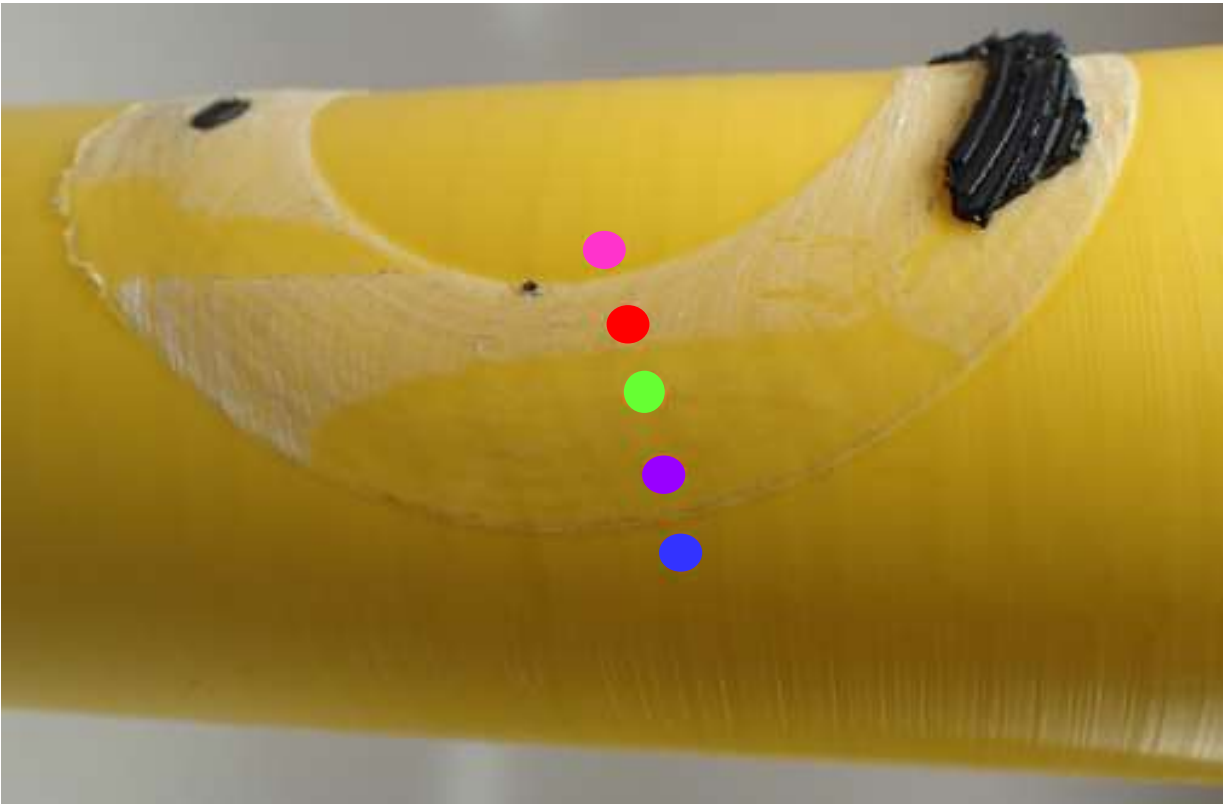

Figure 113. Sample 172318-043, decohesion test result

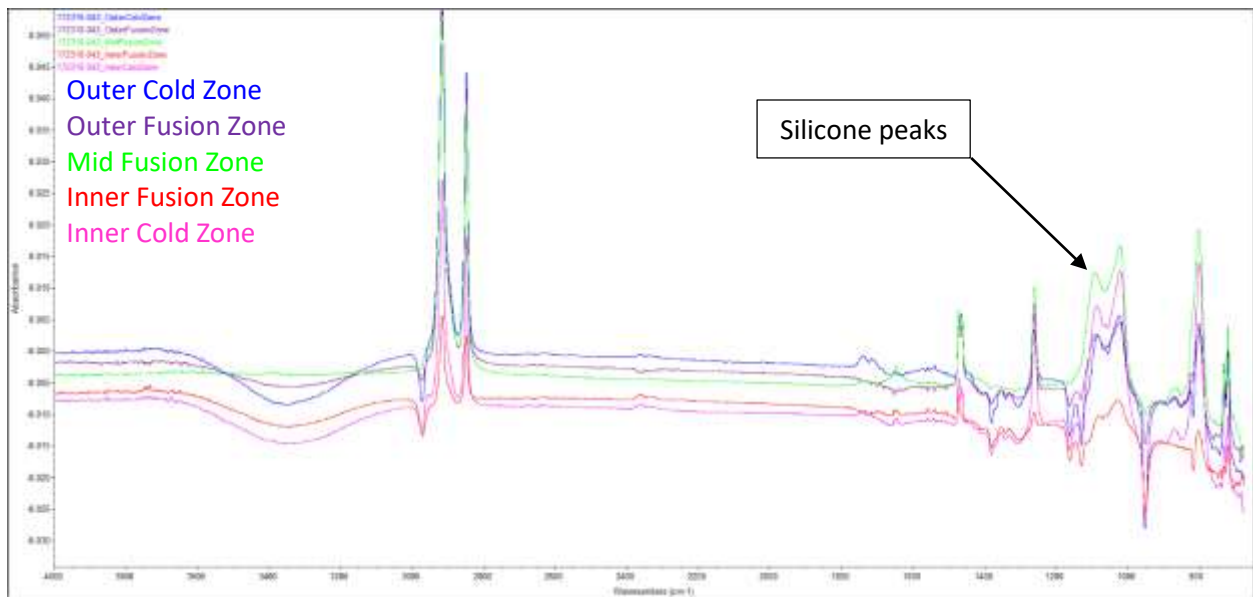

Figure 114. Sample 172318-043, FTIR spectra from decohesion test result

172318-044

172318-044	172395-086	Silicon Grease	Acetone	Lint-Free Wipe
------------	------------	----------------	---------	----------------

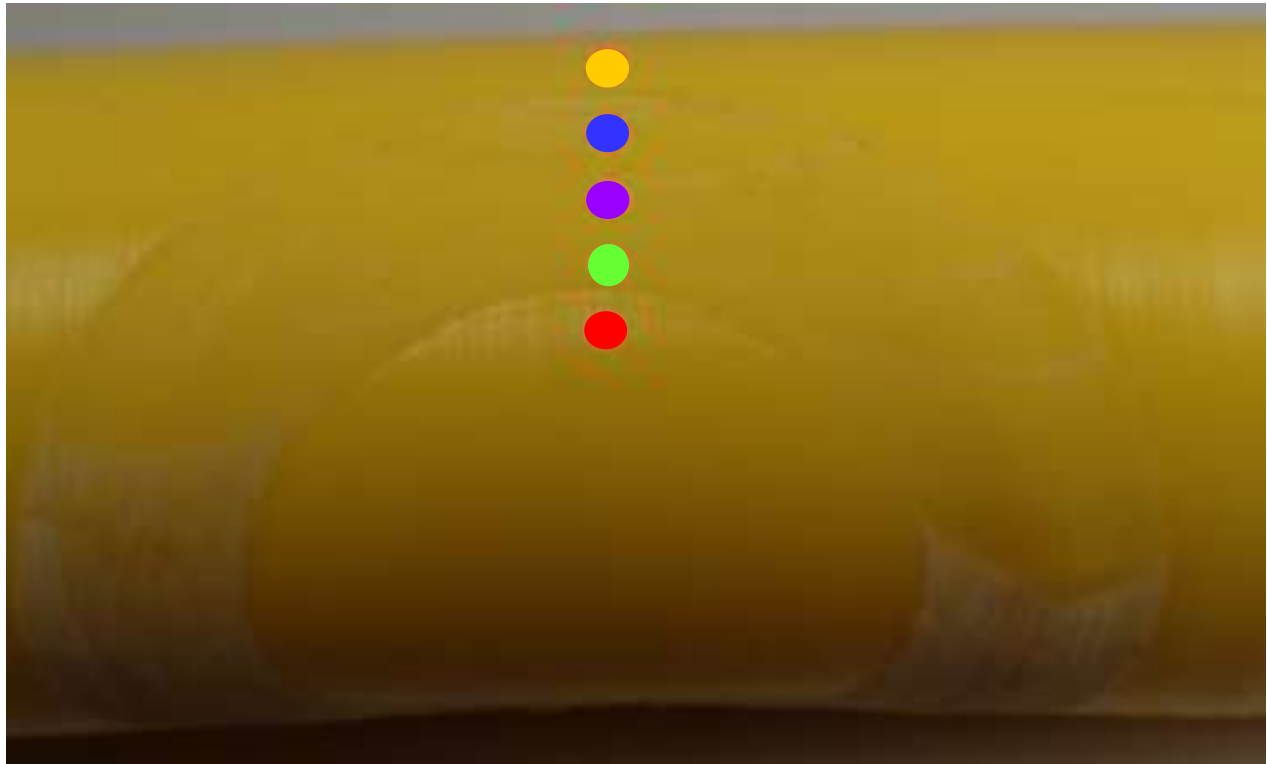

Figure 115. Sample 172318-044, decohesion test result

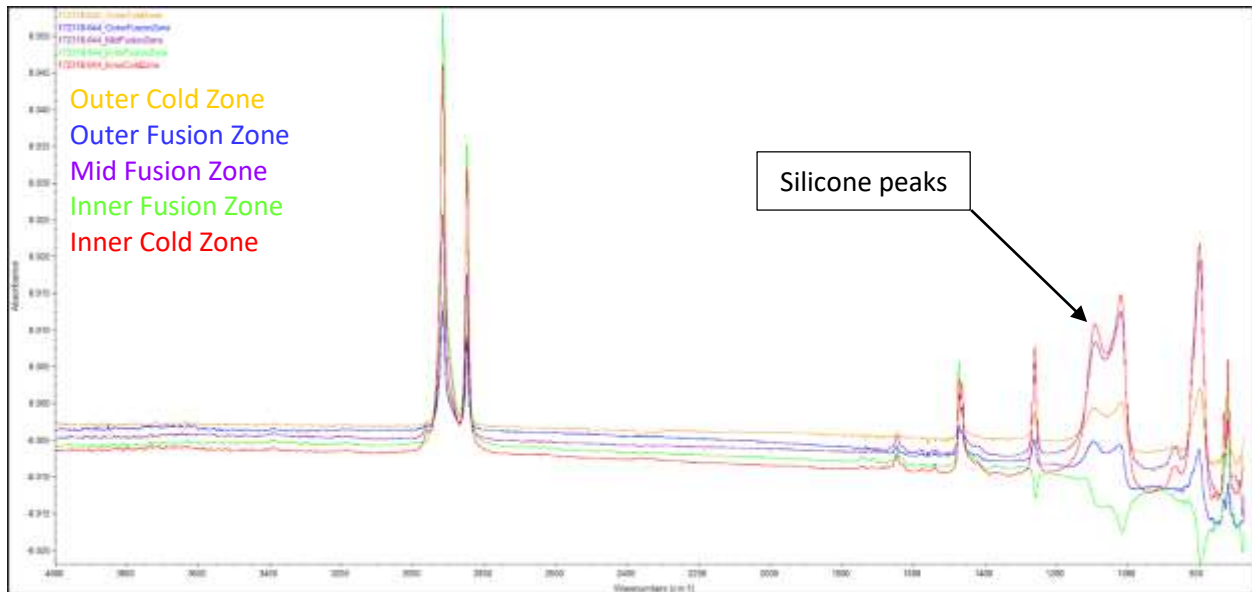

Figure 116. Sample 172318-044, FTIR spectra from decohesion test result

172318-045

172318-045 172395-087 Silicon Grease Acetone Lint-Free Wipe

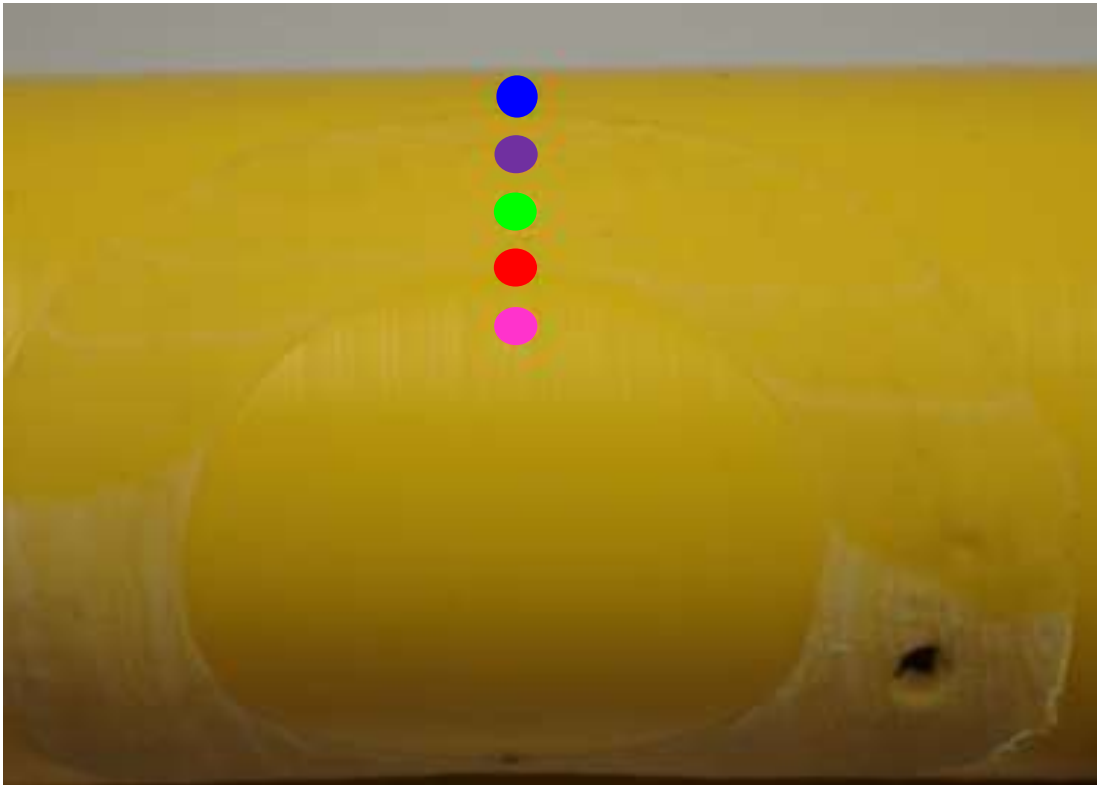

Figure 117. Sample 172318-045, decohesion test result

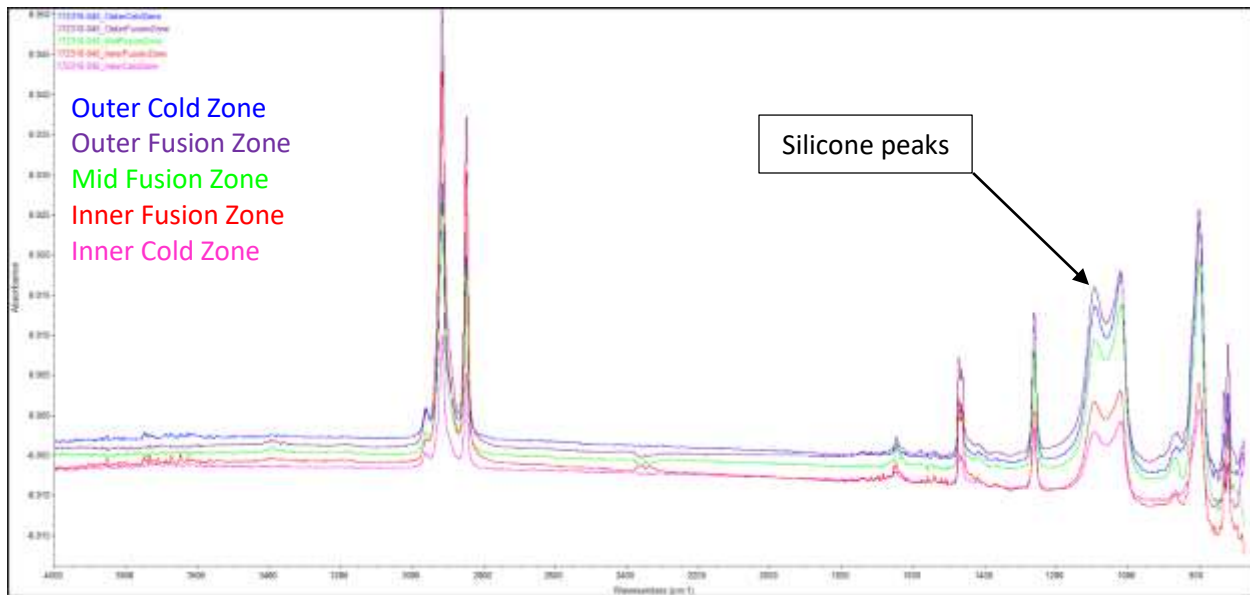

Figure 118. Sample 172318-045, FTIR spectra from decohesion test result

172318-046

172318-046	172395-090	Silicon Grease	Acetone	Cotton Cloth Rag
------------	------------	----------------	---------	------------------

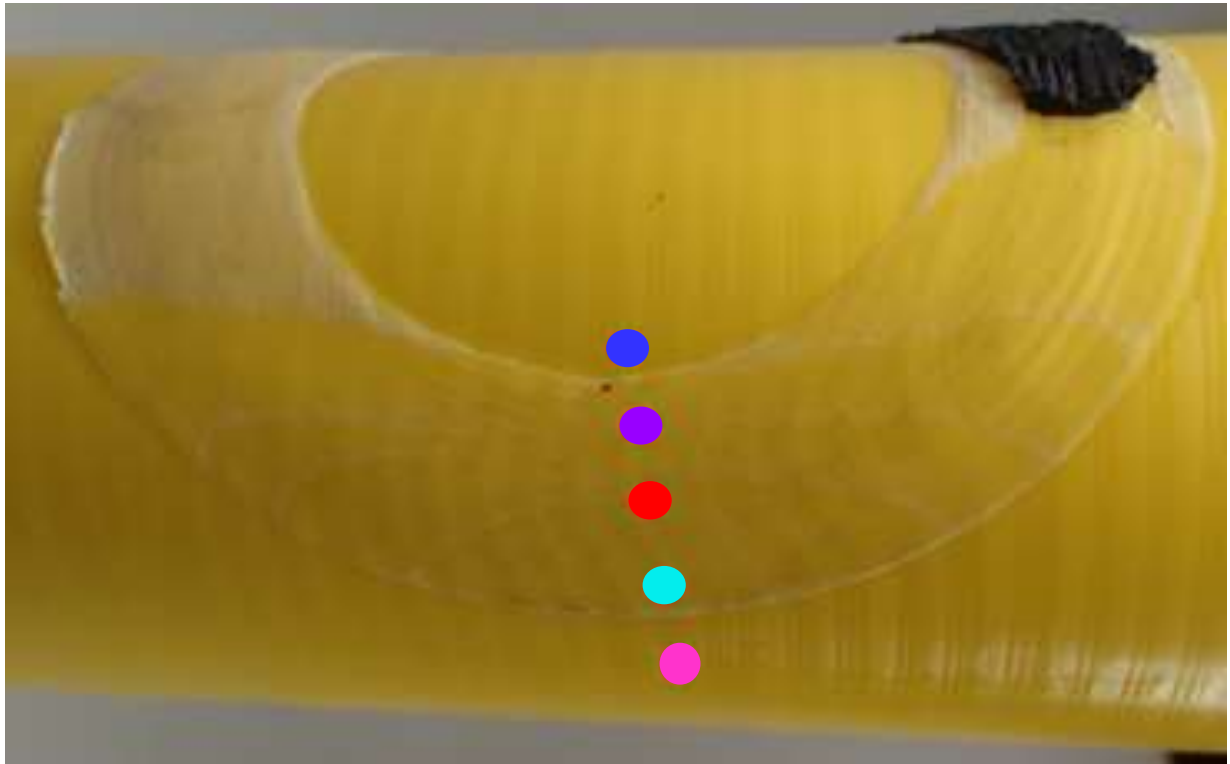

Figure 119. Sample 172318-046, decohesion test result

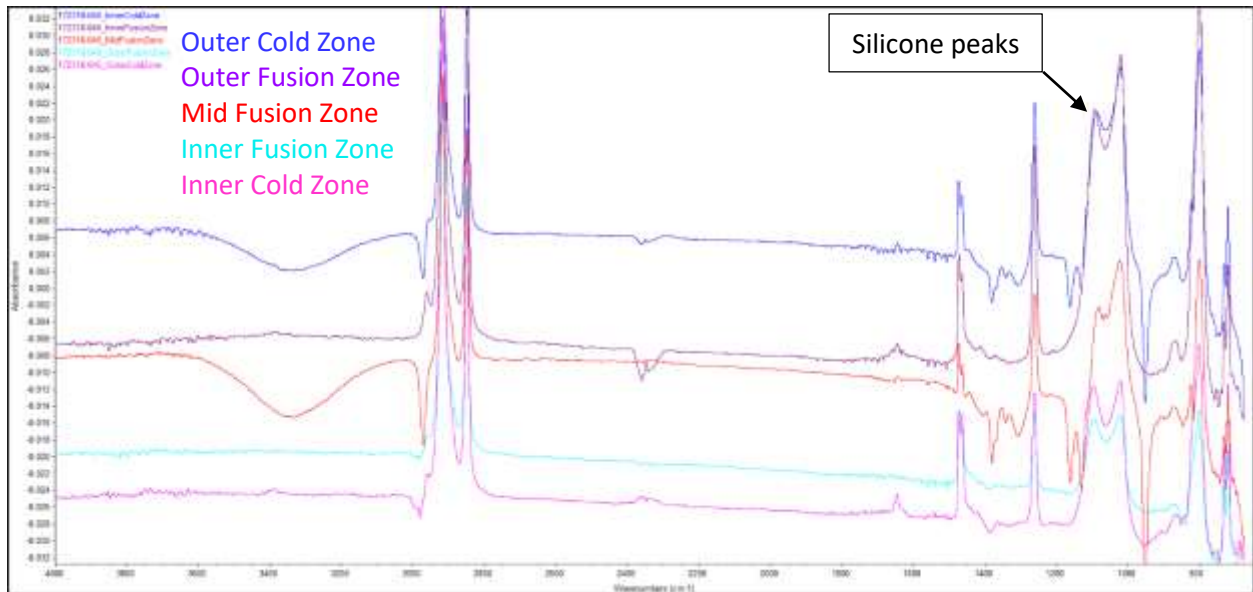

Figure 120. Sample 172318-046, FTIR spectra from decohesion test result

172318-047

172318-047	172395-091	Silicon Grease	Acetone	Cotton Cloth Rag
------------	------------	----------------	---------	------------------

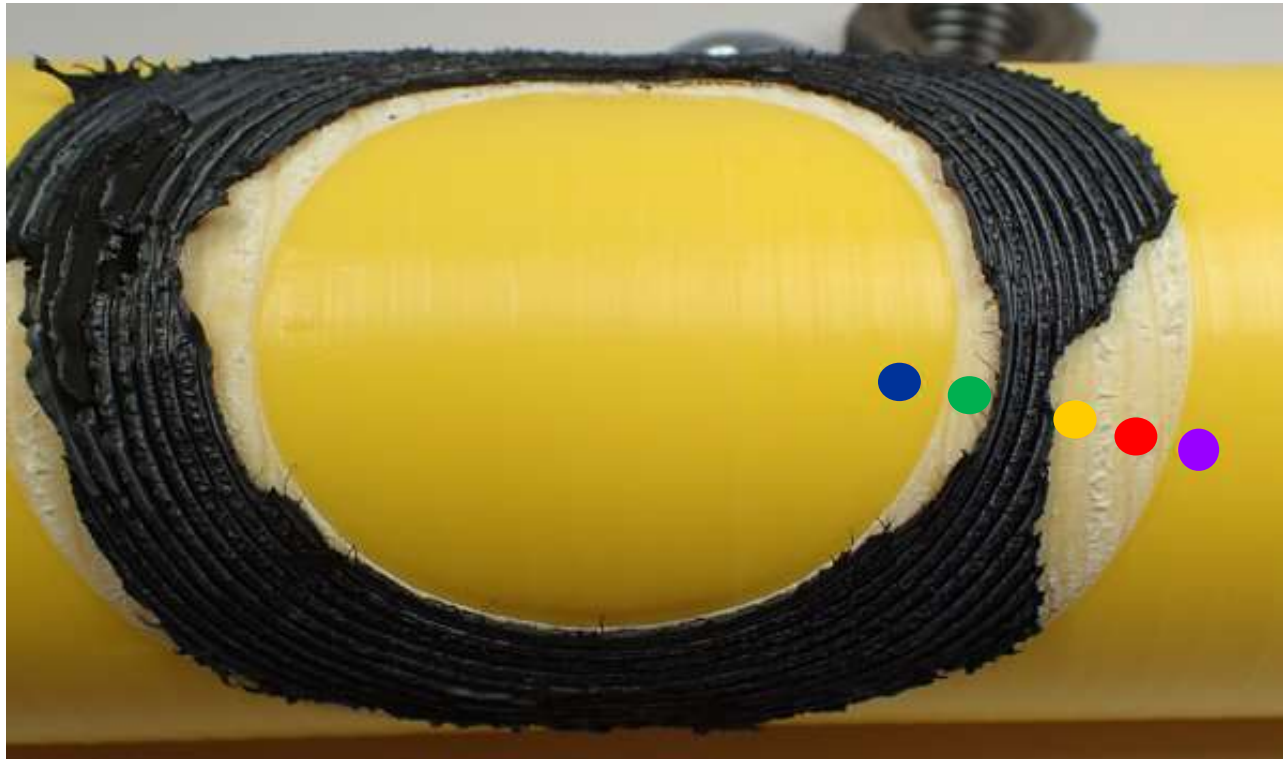

Figure 121. Sample 172318-047, decohesion test result

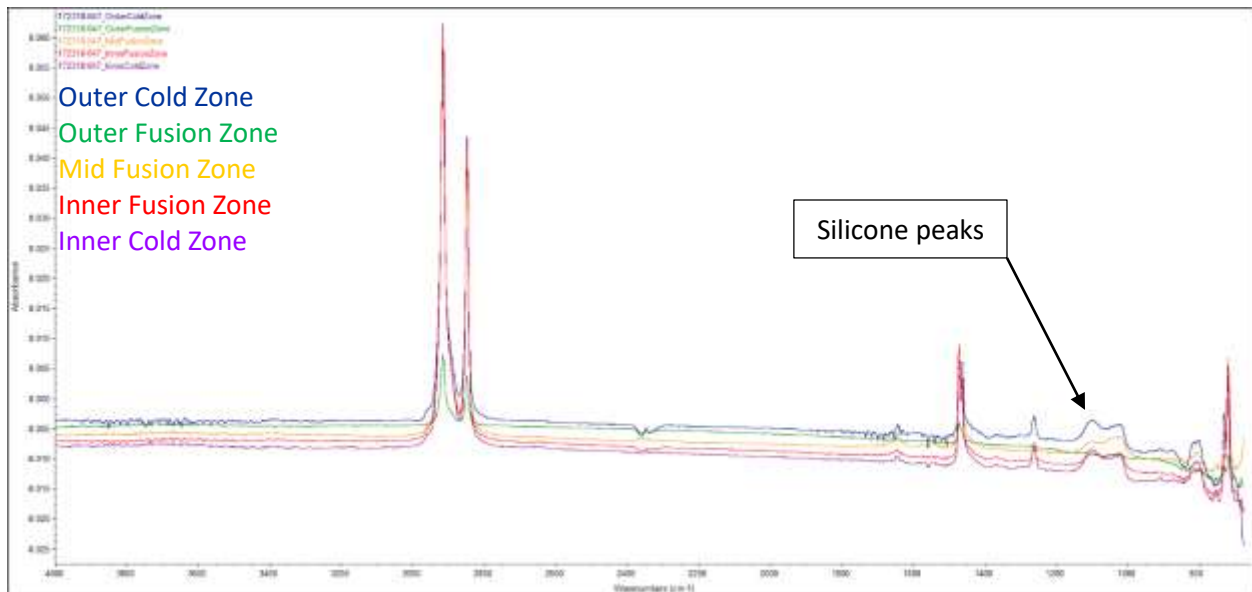

Figure 122. Sample 172318-047, FTIR spectra from decohesion test result

172318-048

172318-048	172395-094	Silicon Grease	Acetone	Paper Towel
------------	------------	----------------	---------	-------------

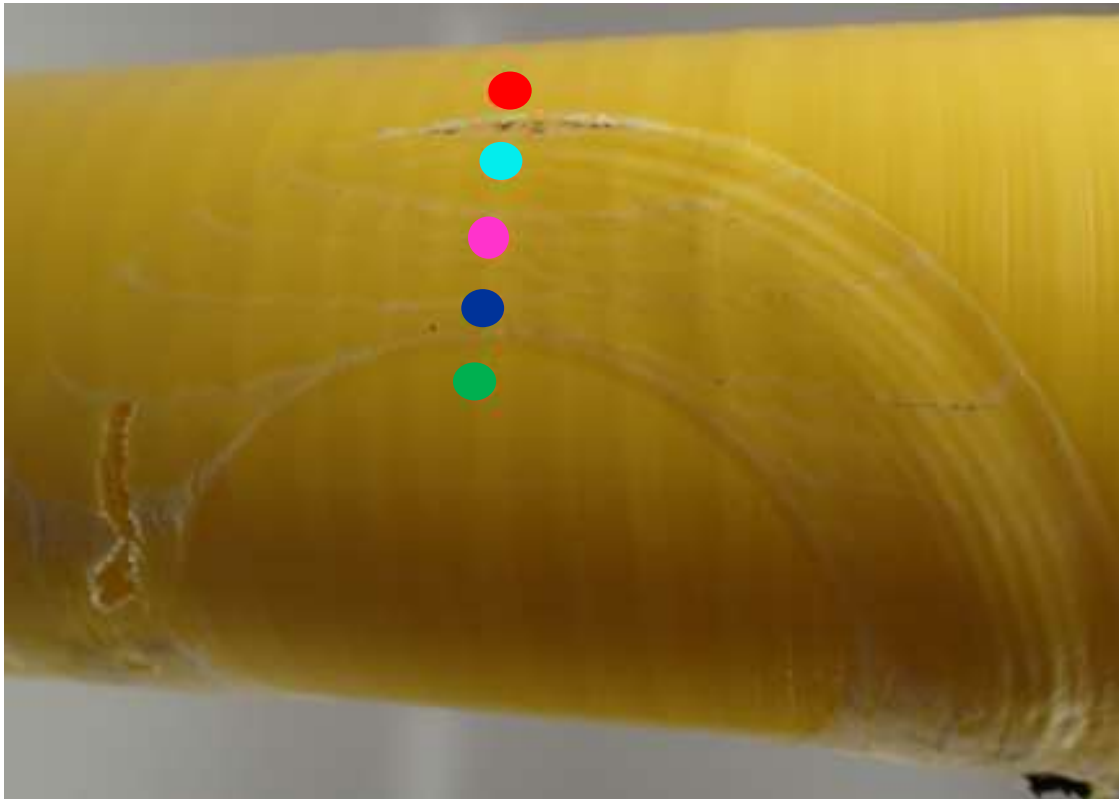

Figure 123. Sample 172318-048, decohesion test result

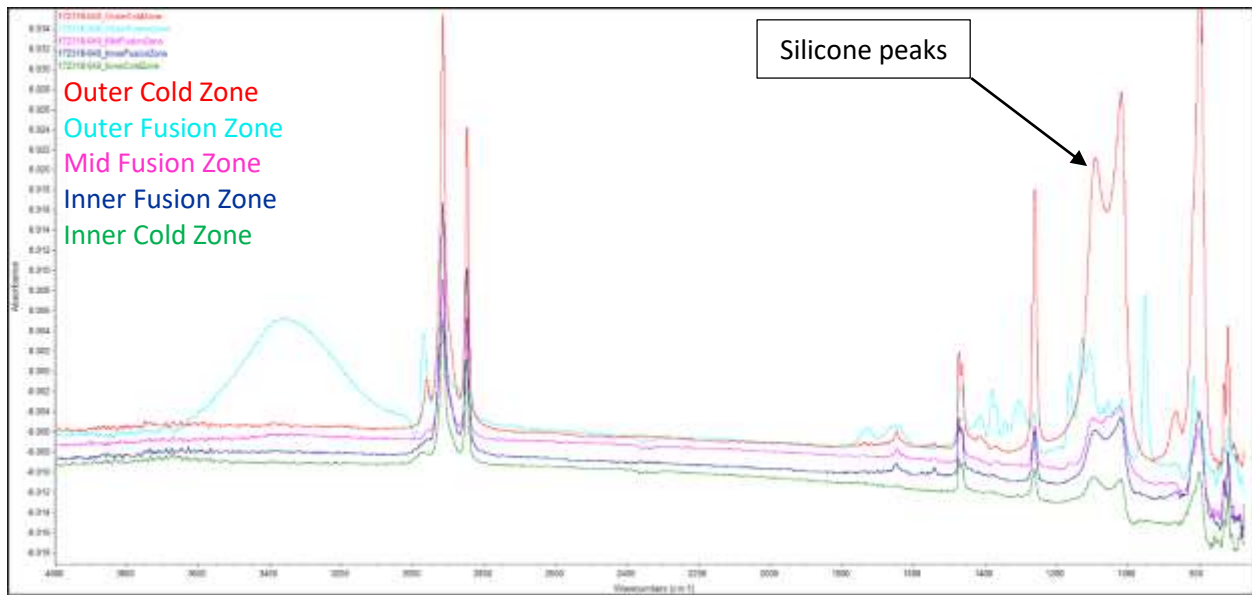

Figure 124. Sample 172318-048, FTIR spectra from decohesion test result

172318-049

172318-049	172395-095	Silicon Grease	Acetone	Paper Towel
------------	------------	----------------	---------	-------------

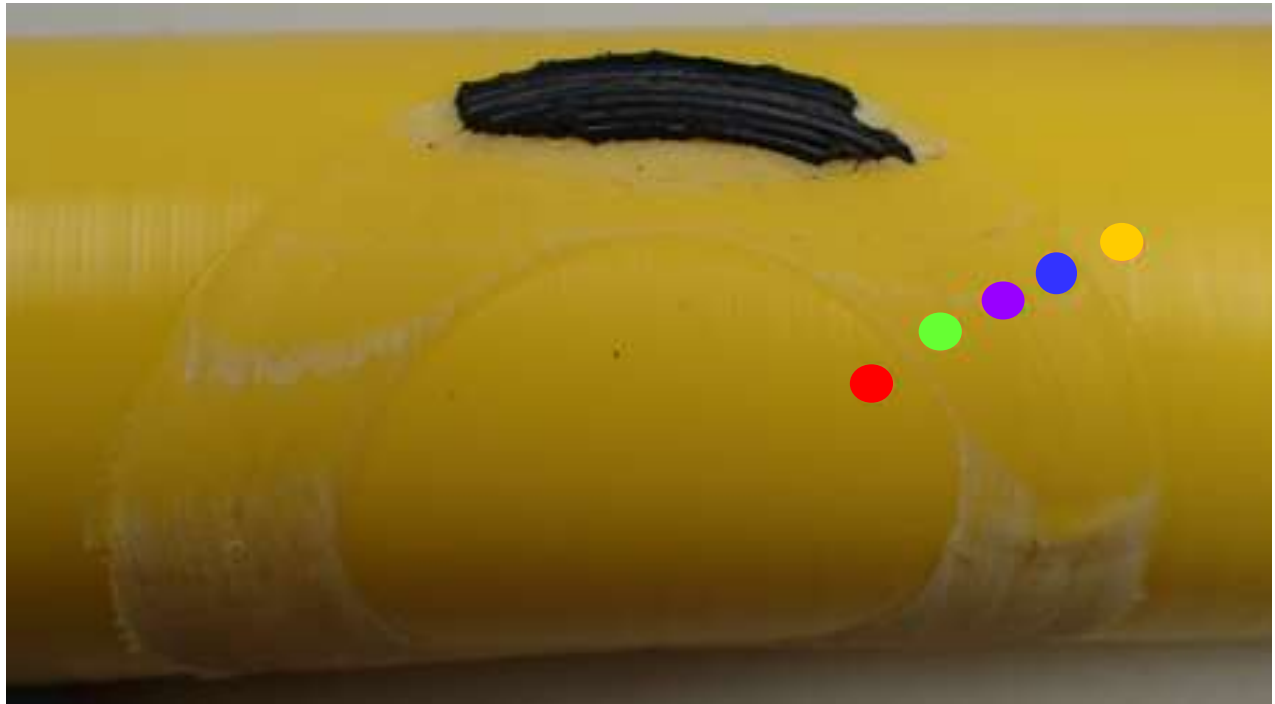

Figure 125. Sample 172318-049, decohesion test result

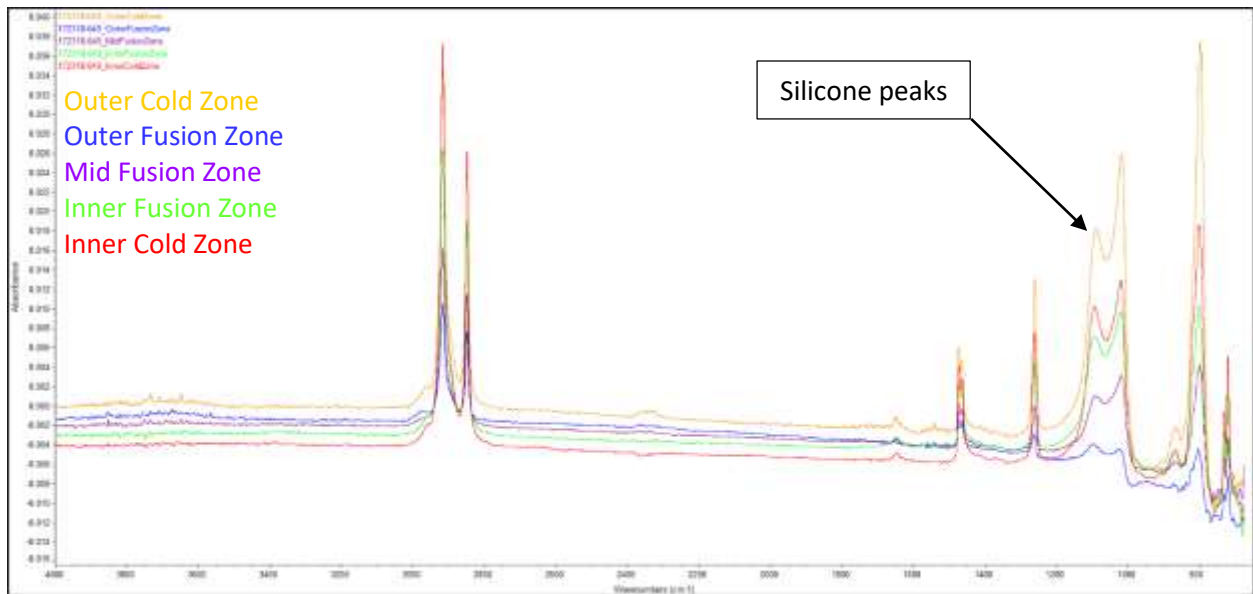

Figure 126. Sample 172318-049, FTIR spectra from decohesion test result

172318-050

172318-050 172395-098 Silicon Grease 99% Isopropanol Cotton Cloth Rag

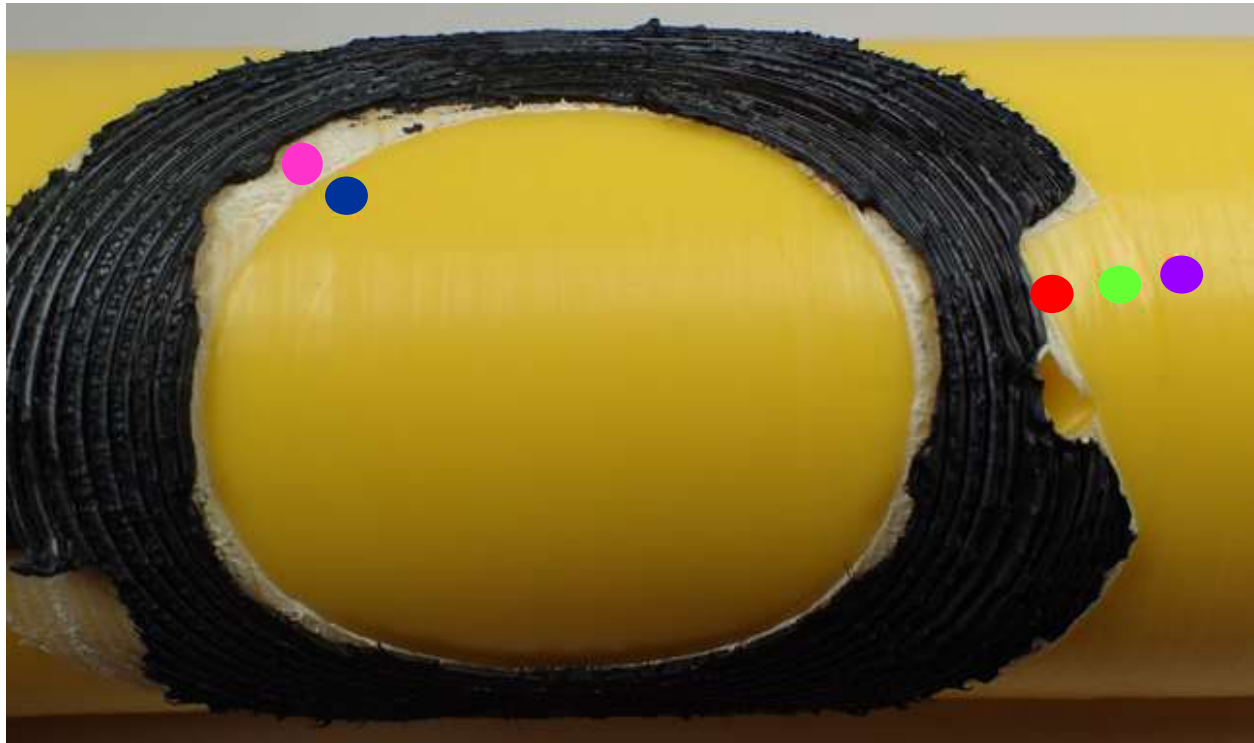

Figure 127. Sample 172318-050, decohesion test result

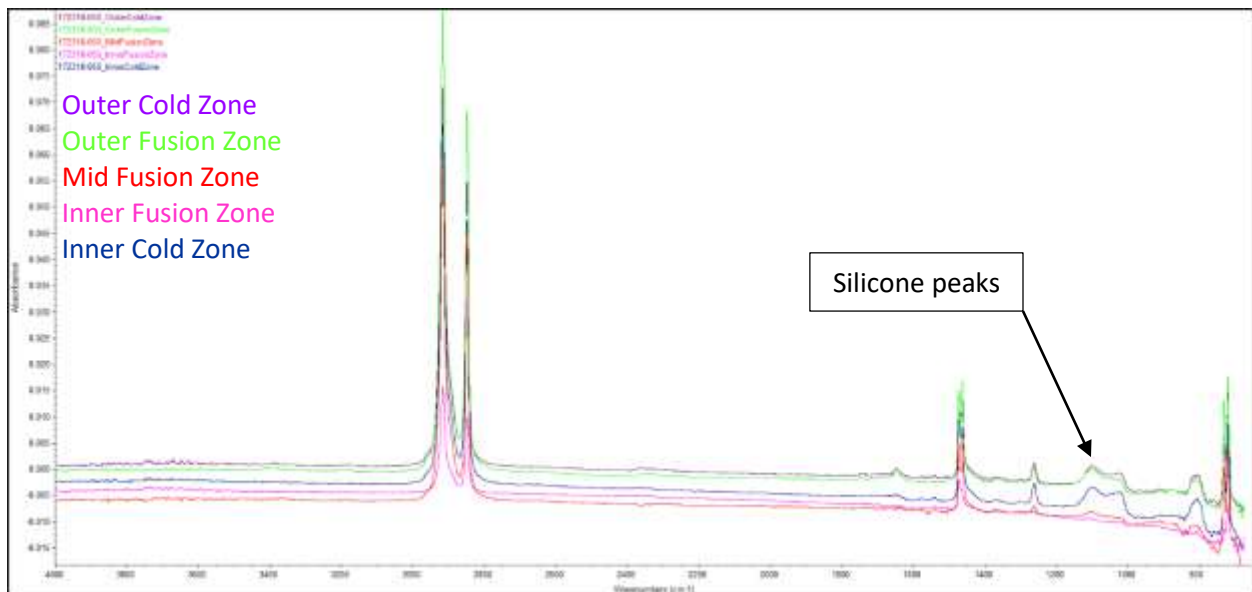

Figure 128. Sample 172318-050, FTIR spectra from decohesion test result

172318-051

172318-051 172395-101 Silicon Grease 99% Isopropanol Paper Towel

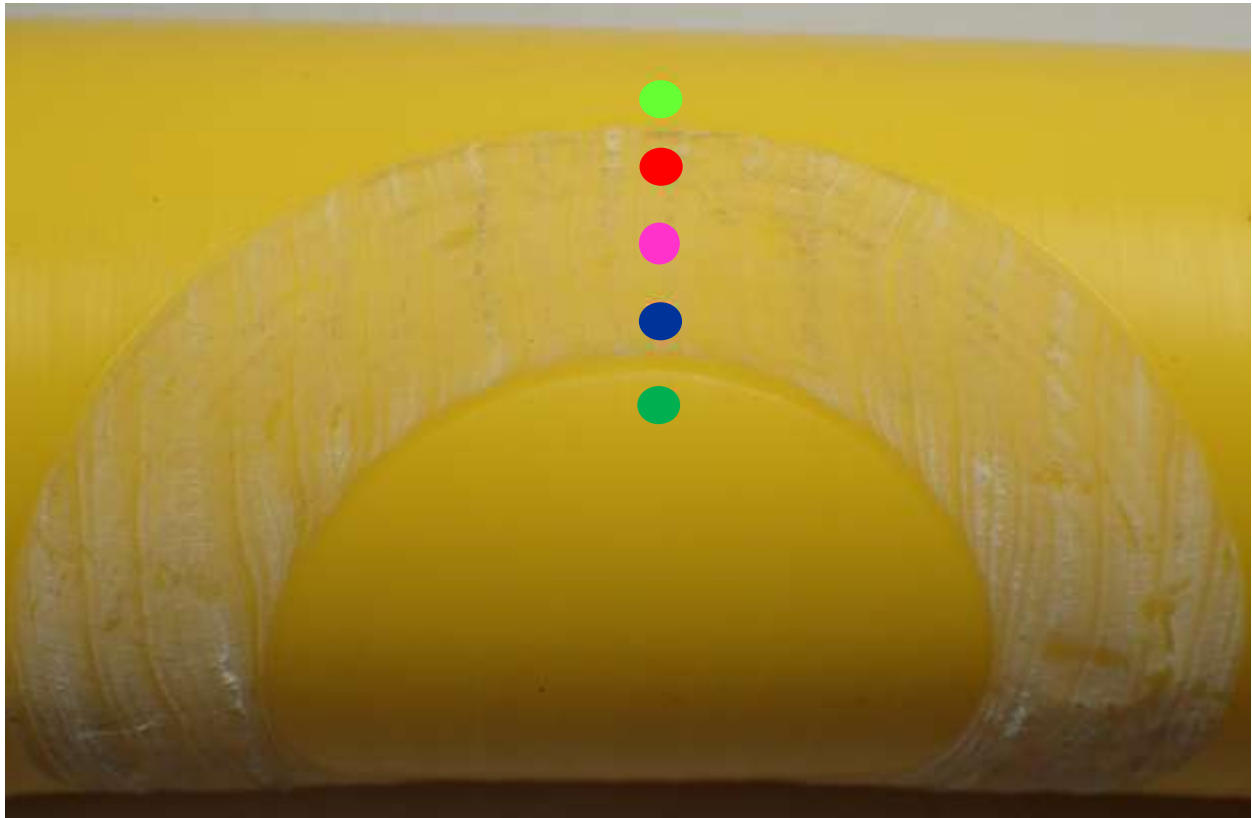

Figure 129. Sample 172318-051, decohesion test result

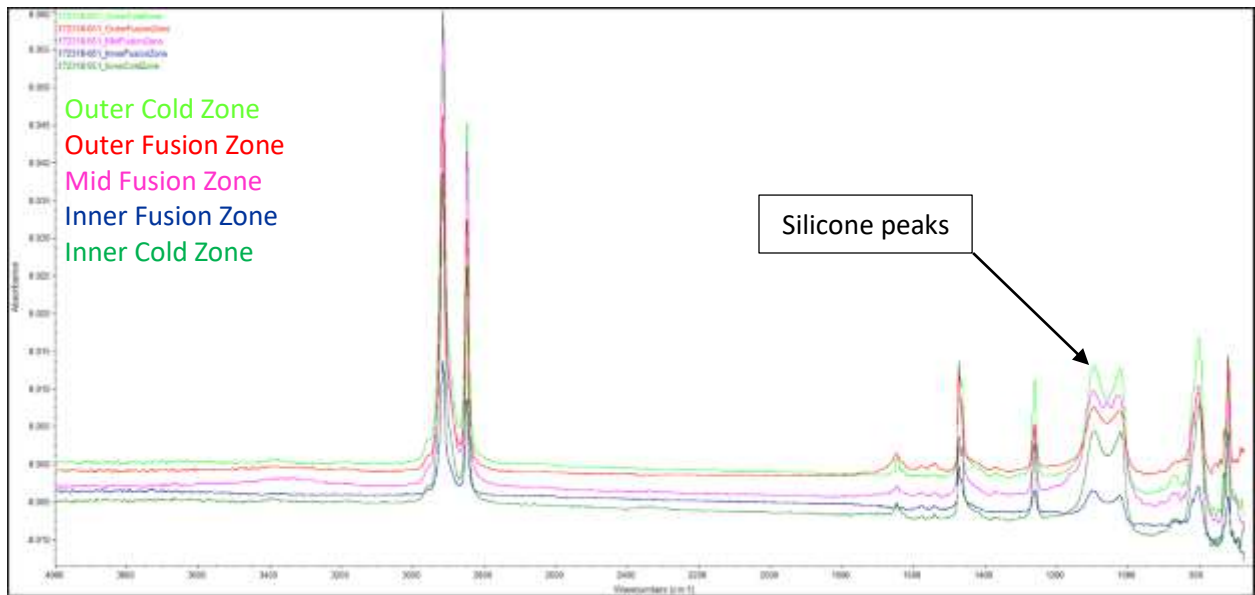

Figure 130. Sample 172318-051, FTIR spectra from decohesion test result

172318-052

172318-052 172395-102 Silicon Grease 99% Isopropanol Paper Towel

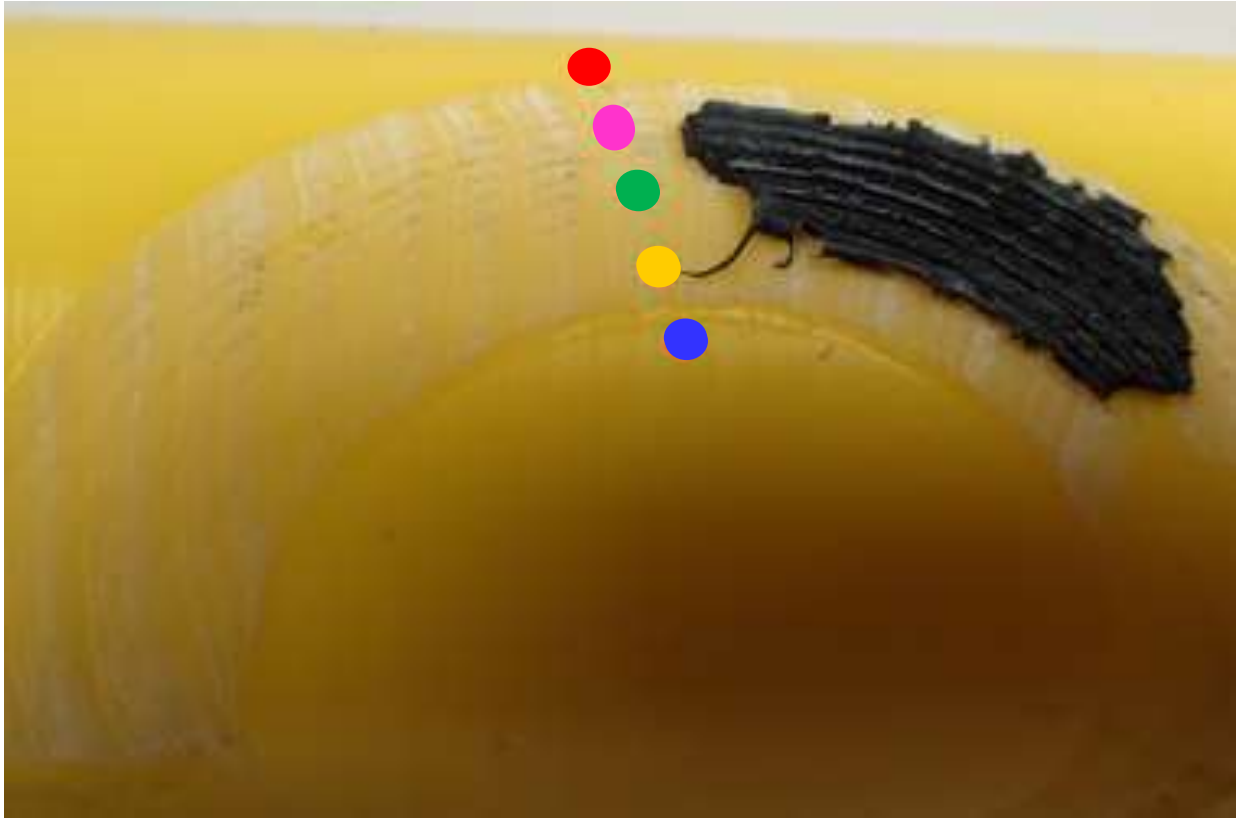

Figure 131. Sample 172318-052, decohesion test result

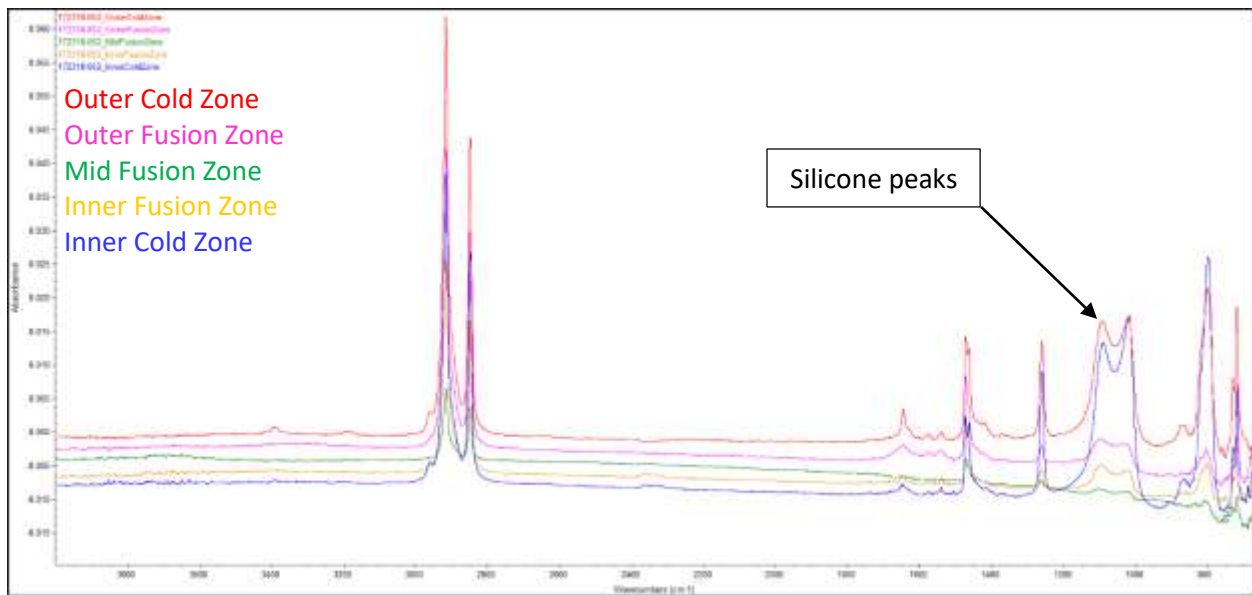

Figure 132. Sample 172318-052, FTIR spectra from decohesion test result

172318-053

172318-053	172395-105	Silicon Grease	91% Isopropanol	Lint-Free Wipe
------------	------------	----------------	-----------------	----------------

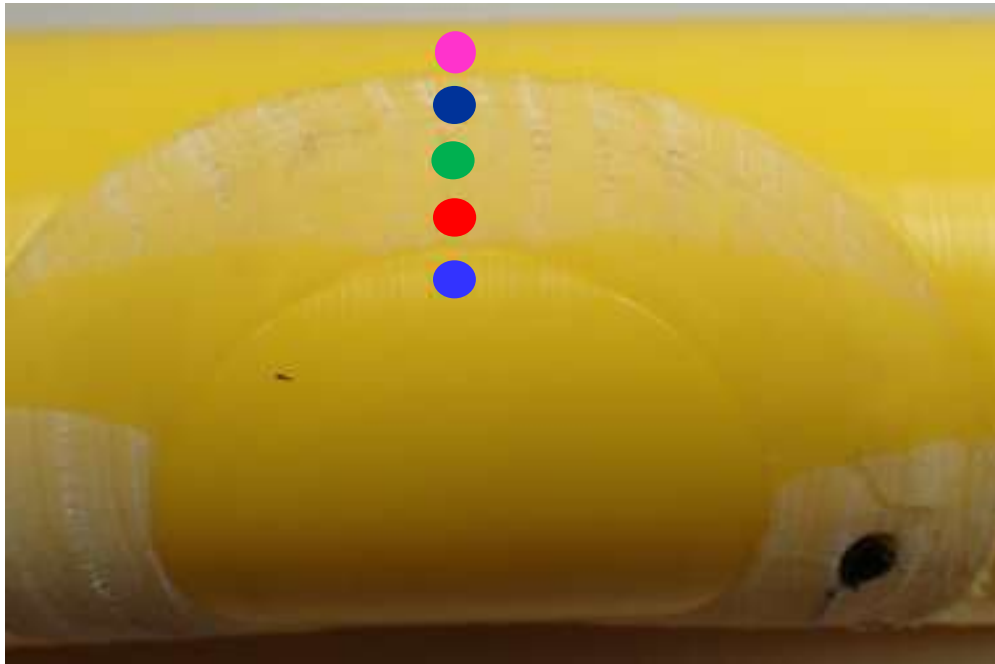

Figure 133. Sample 172318-053, decohesion test result

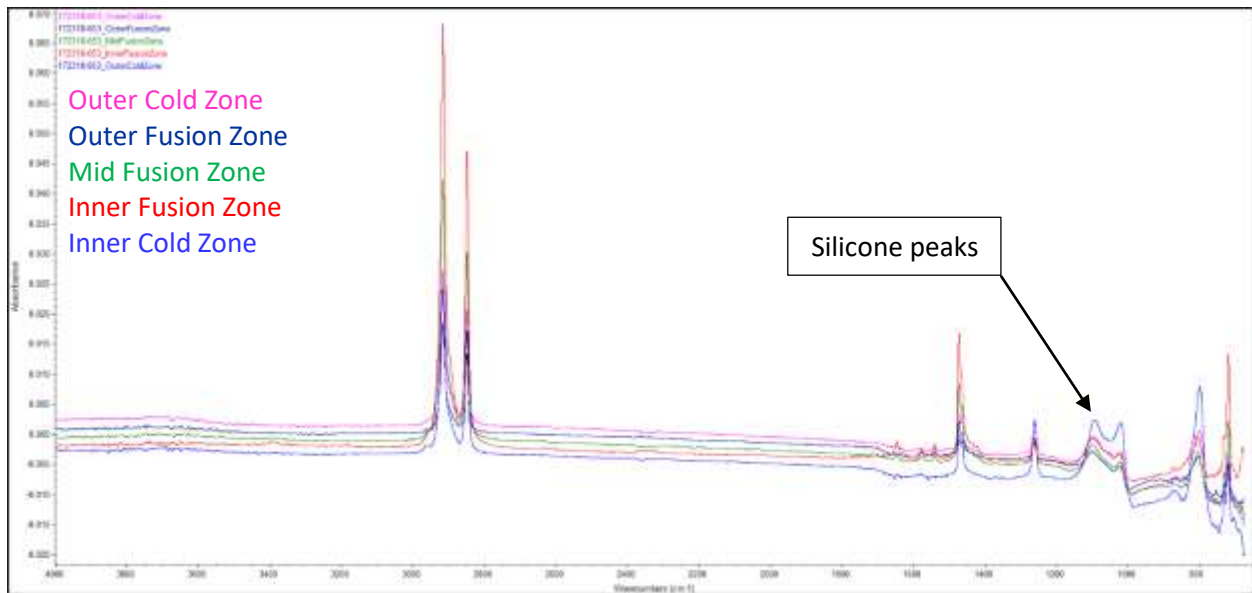

Figure 134. Sample 172318-053, FTIR spectra from decohesion test result

172318-054

172318-054 172395-106 Silicon Grease 91% Isopropanol Lint-Free Wipe

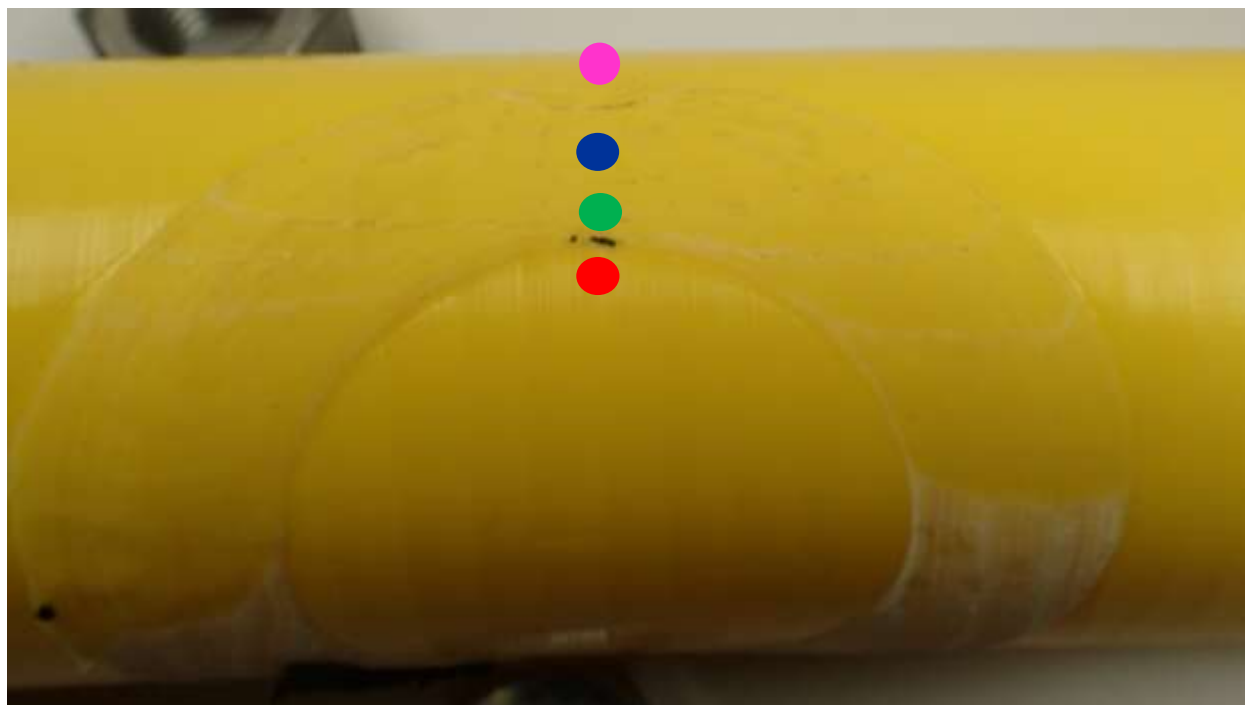

Figure 135. Sample 172318-054, decohesion test result

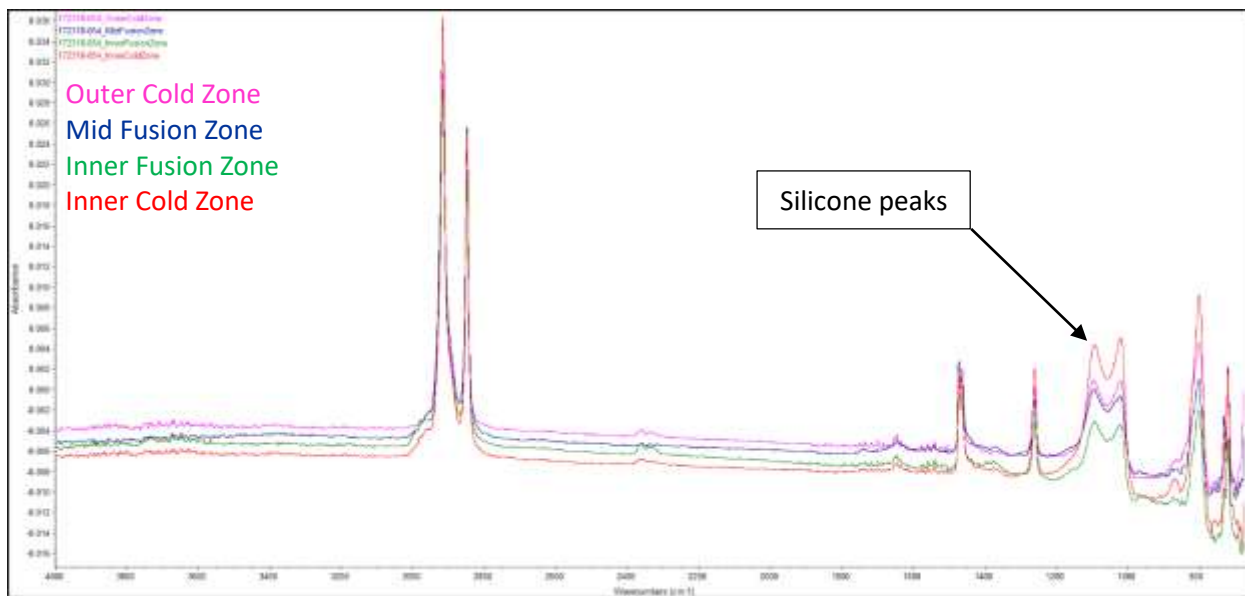

Figure 136. Sample 172318-054, FTIR spectra from decohesion test result

172318-055

172318-055 172395-109 Silicon Grease 91% Isopropanol Cotton Cloth Rag



Figure 137. Sample 172318-055, decohesion test result

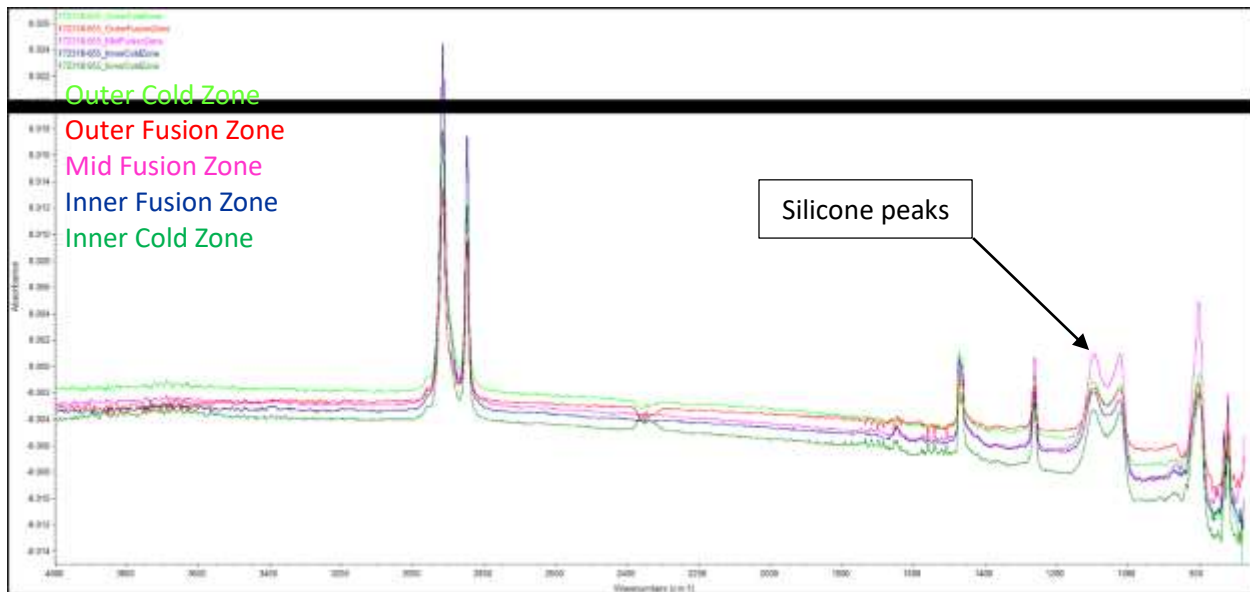

Figure 138. Sample 172318-055, FTIR spectra from decohesion test result

172318-057

172318-057 172395-113 Silicon Grease 91% Isopropanol Paper Towel

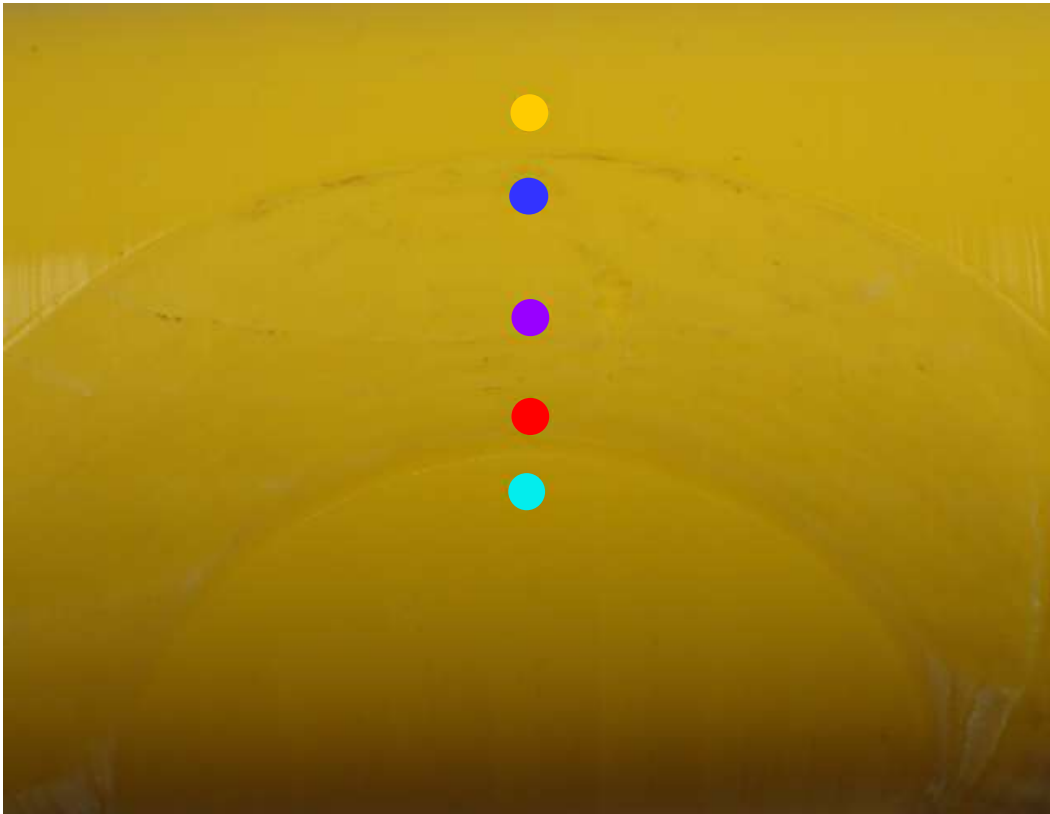

Figure 139. Sample 172318-057, decohesion test result

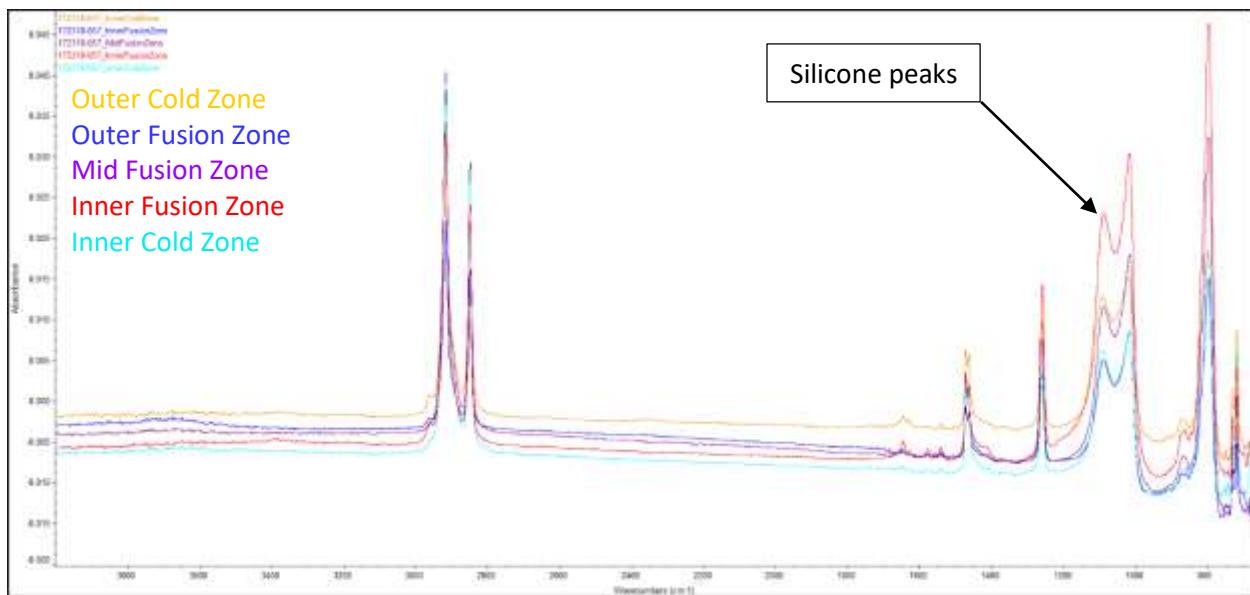

Figure 140. Sample 172318-057, FTIR spectra from decohesion test result

172318-058

172318-058	172395-114	Silicon Grease	91% Isopropanol	Paper Towel
------------	------------	----------------	-----------------	-------------

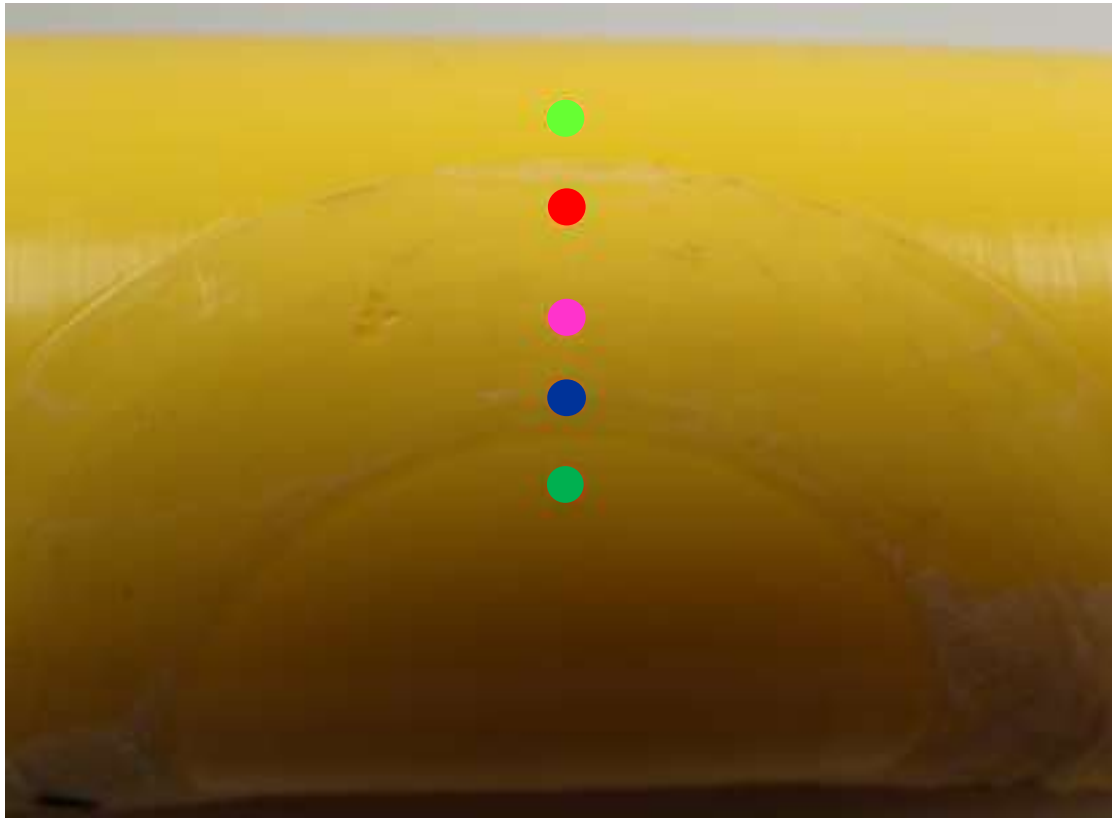

Figure 141. Sample 172318-058, decohesion test result

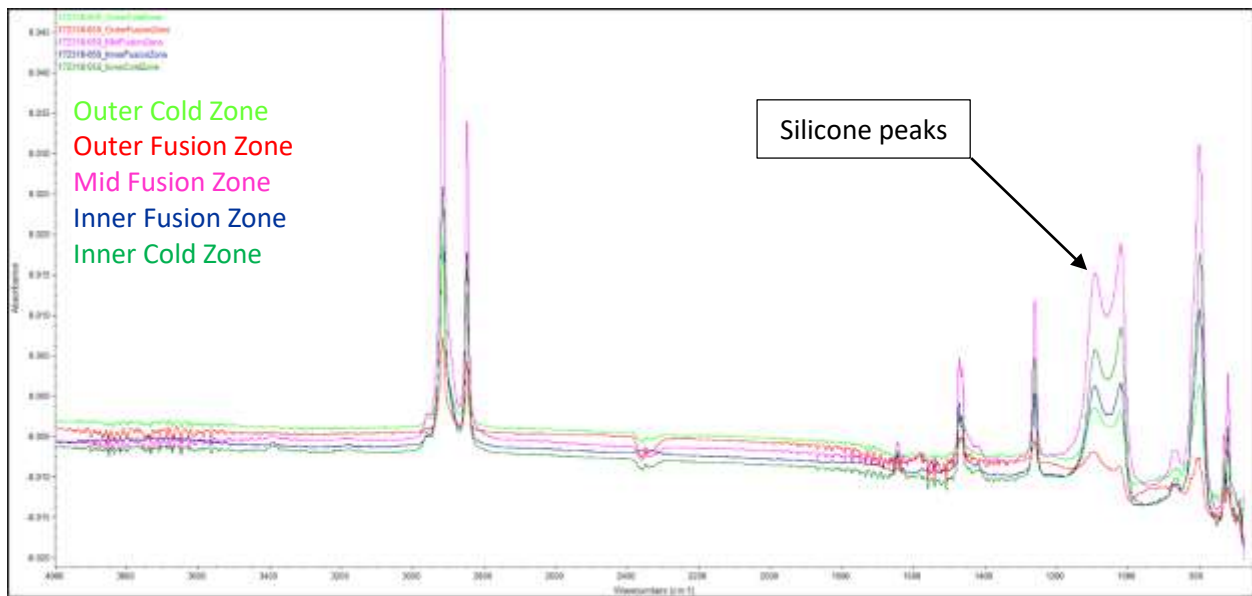

Figure 142. Sample 172318-058, FTIR spectra from decohesion test result

172316-032

172316-032	172395-011	Talc	99% Isopropanol	Lint-Free Wipe
------------	------------	------	-----------------	----------------

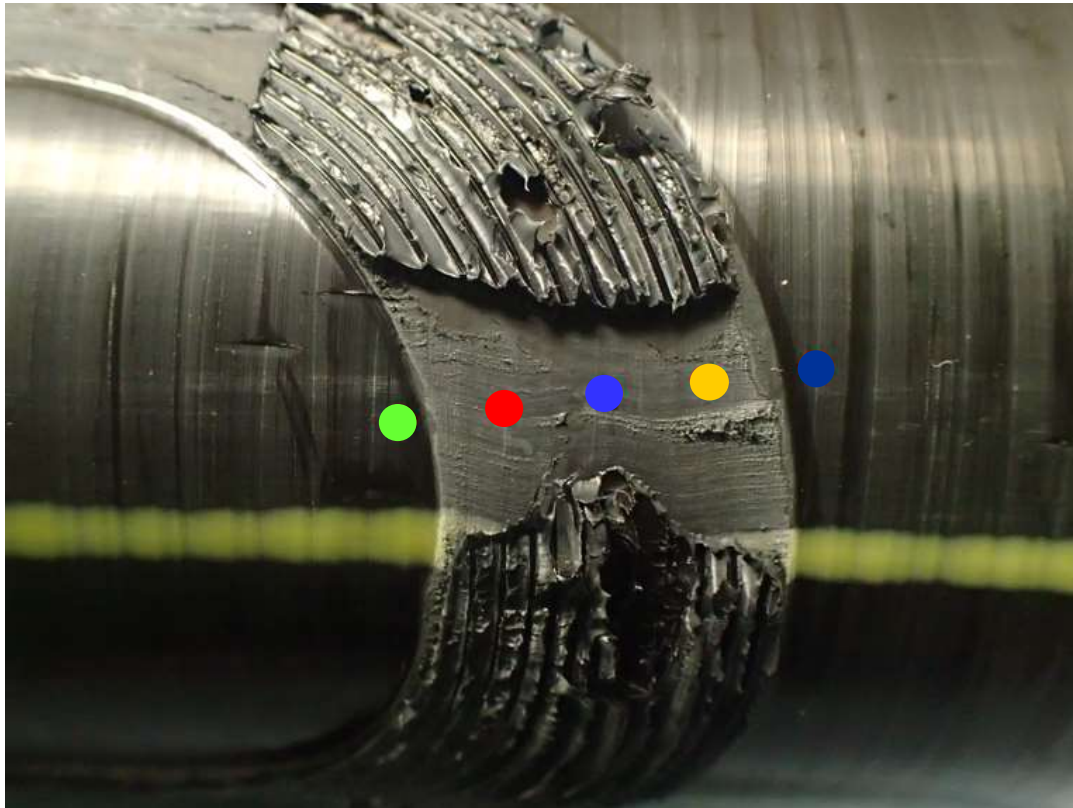

Figure 143. Sample 172316-032, decohesion test result

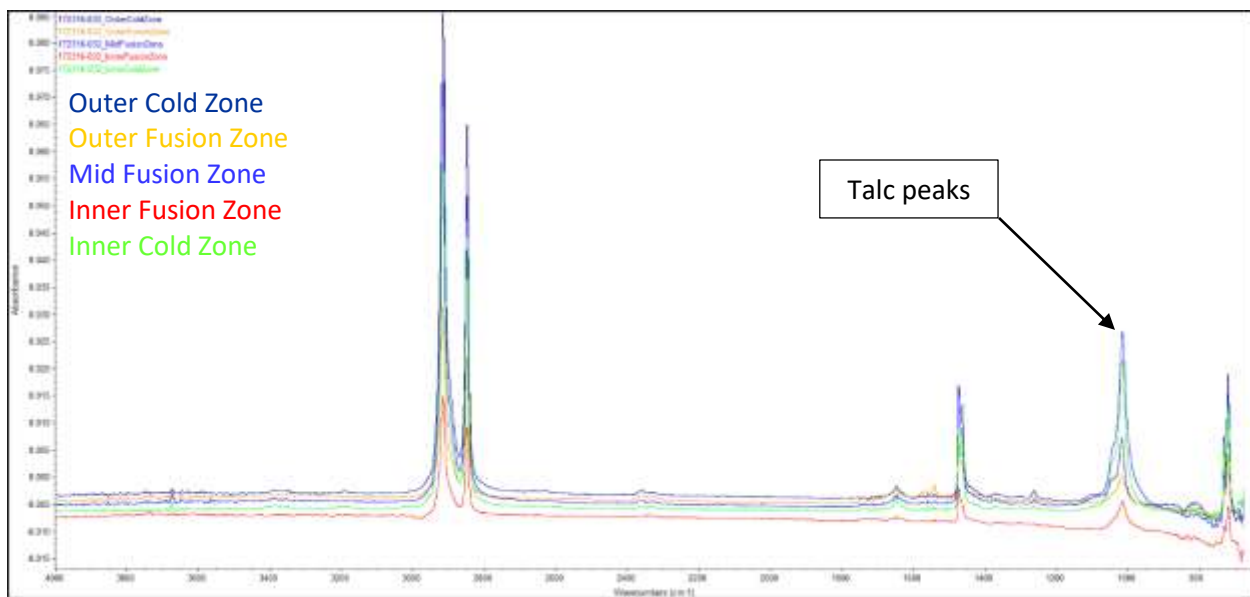

Figure 144. Sample 172316-032, FTIR spectra from decohesion test result

172316-033

172316-033	172395-012	Talc	99% Isopropanol	Paper Towel
------------	------------	------	-----------------	-------------

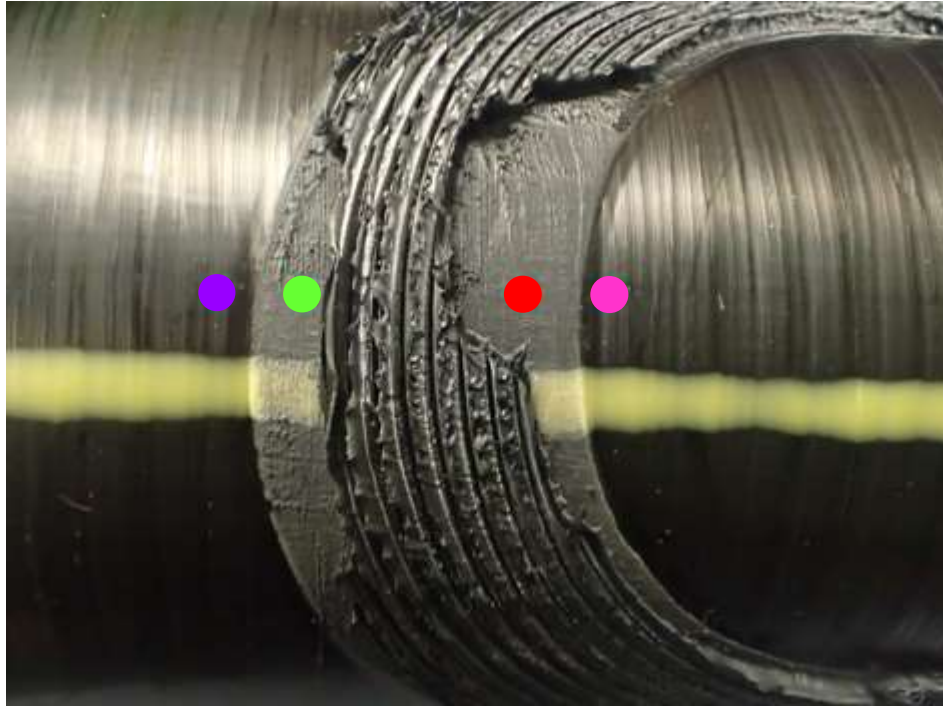

Figure 145. Sample 172316-033, decohesion test result

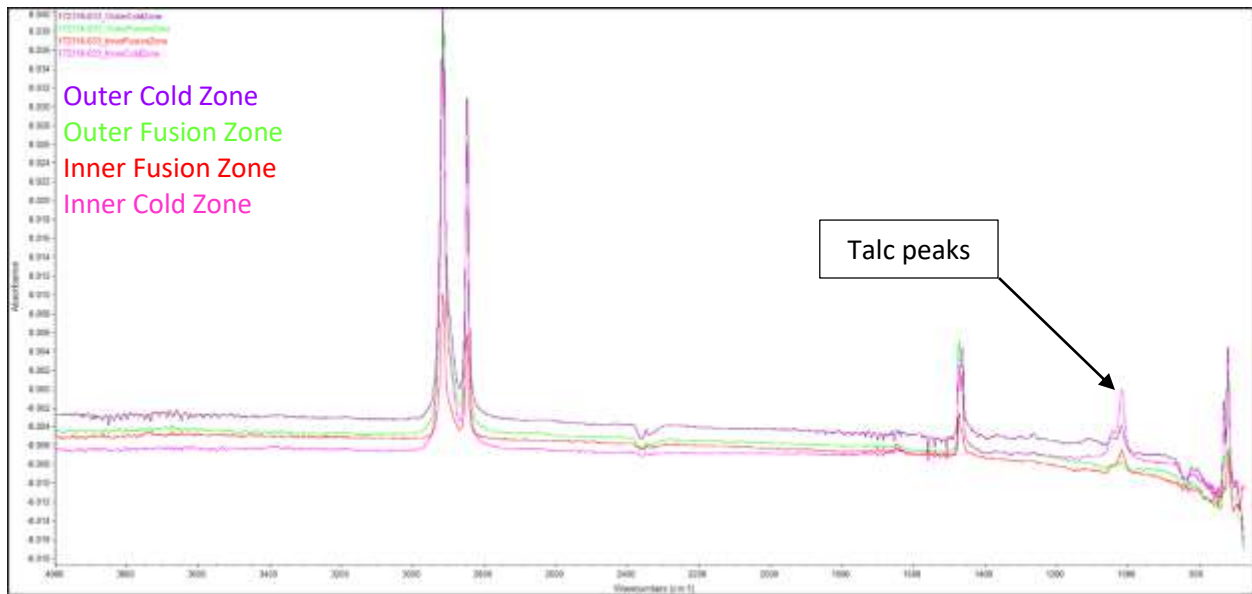

Figure 146. Sample 172316-033, FTIR spectra from decohesion test result

172316-035

172316-035	172395-015	Talc	99% Isopropanol	Cotton Cloth Rag
------------	------------	------	-----------------	------------------

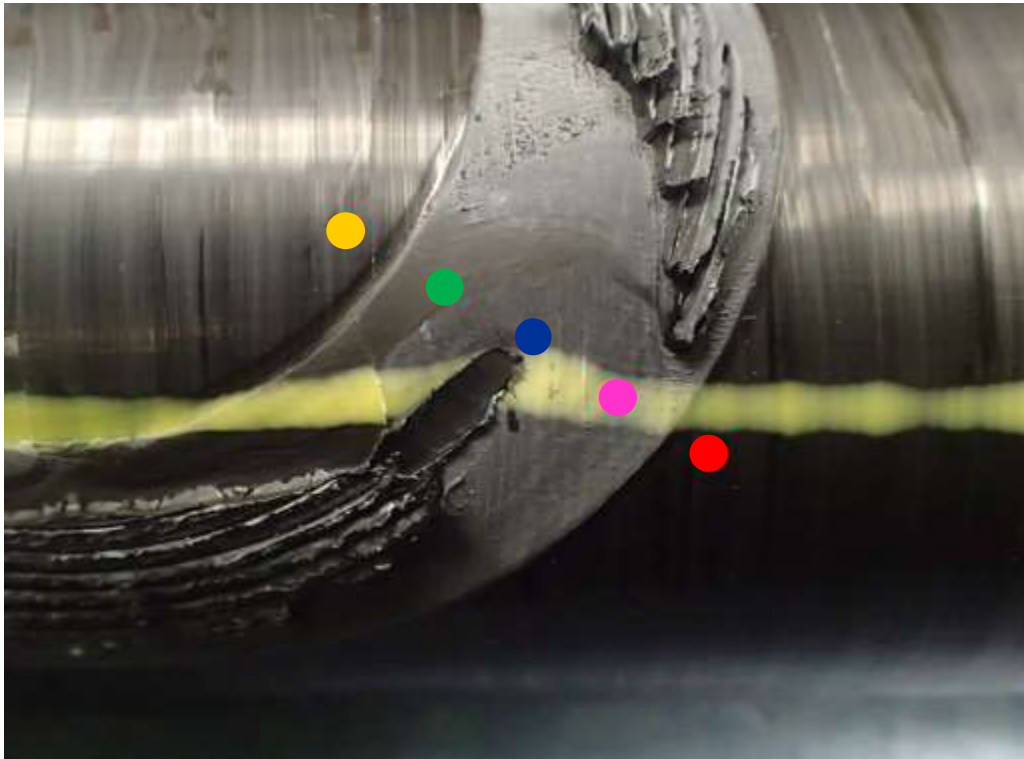

Figure 147. Sample 172316-035, decohesion test result

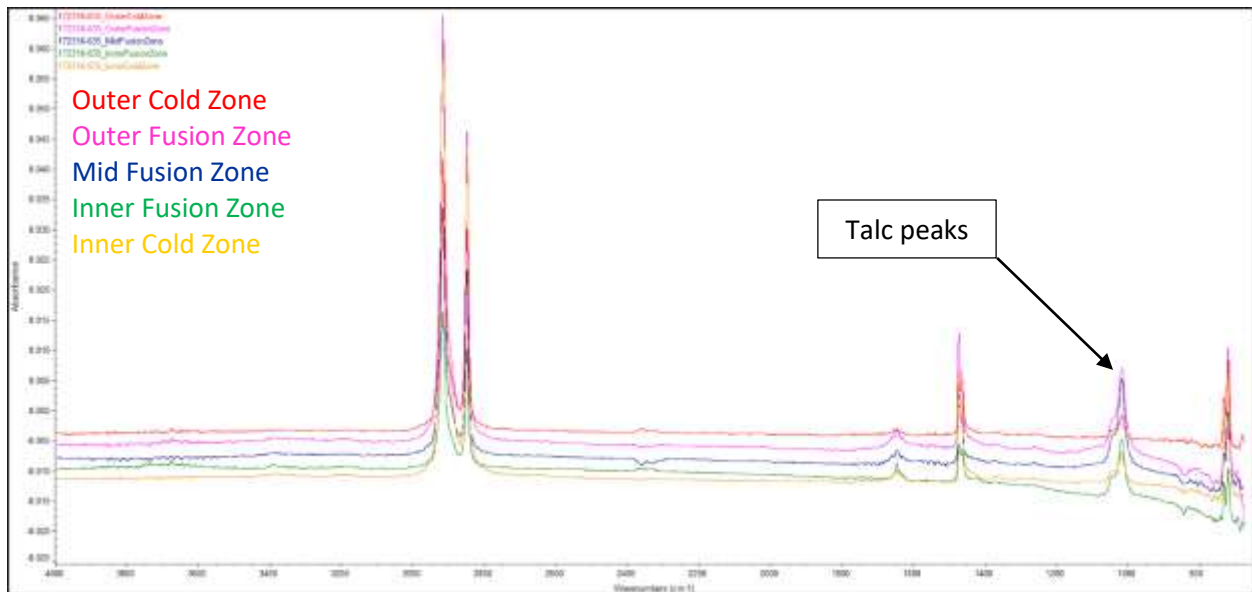

Figure 148. Sample 172316-035, FTIR spectra from decohesion test result

172316-036

172316-036	172395-016	Talc	99% Isopropanol	Cotton Cloth Rag
------------	------------	------	-----------------	------------------



Figure 149. Sample 172316-036, decohesion test result

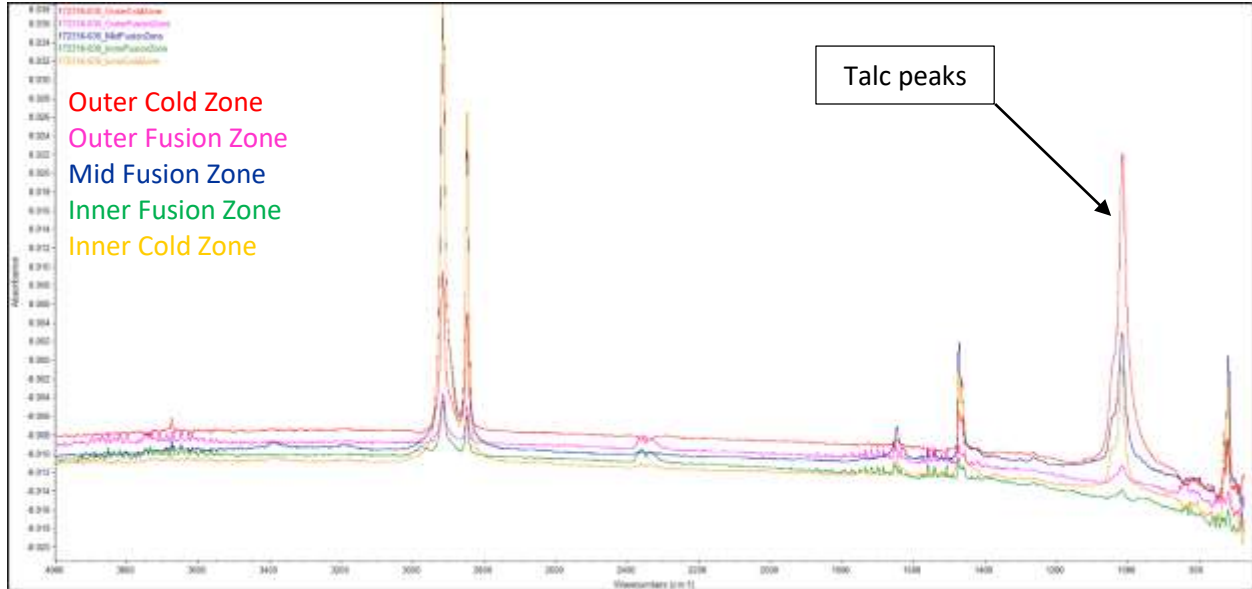

Figure 150. Sample 172316-036, FTIR spectra from decohesion test result

172316-037

172316-037	172395-017	Talc	91% Isopropanol	Cotton Cloth Rag
------------	------------	------	-----------------	------------------

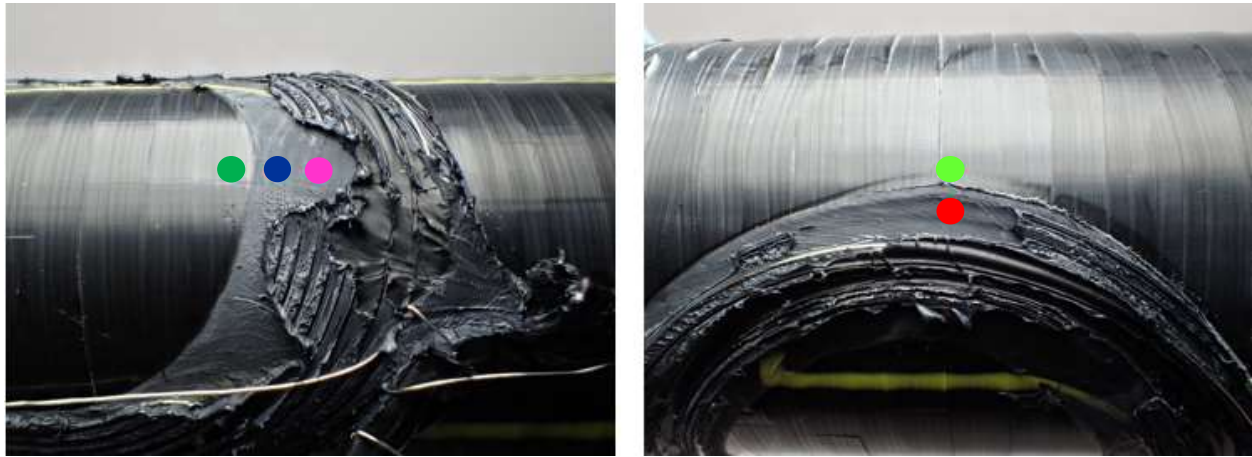

Figure 151. Sample 172316-037, decohesion test result

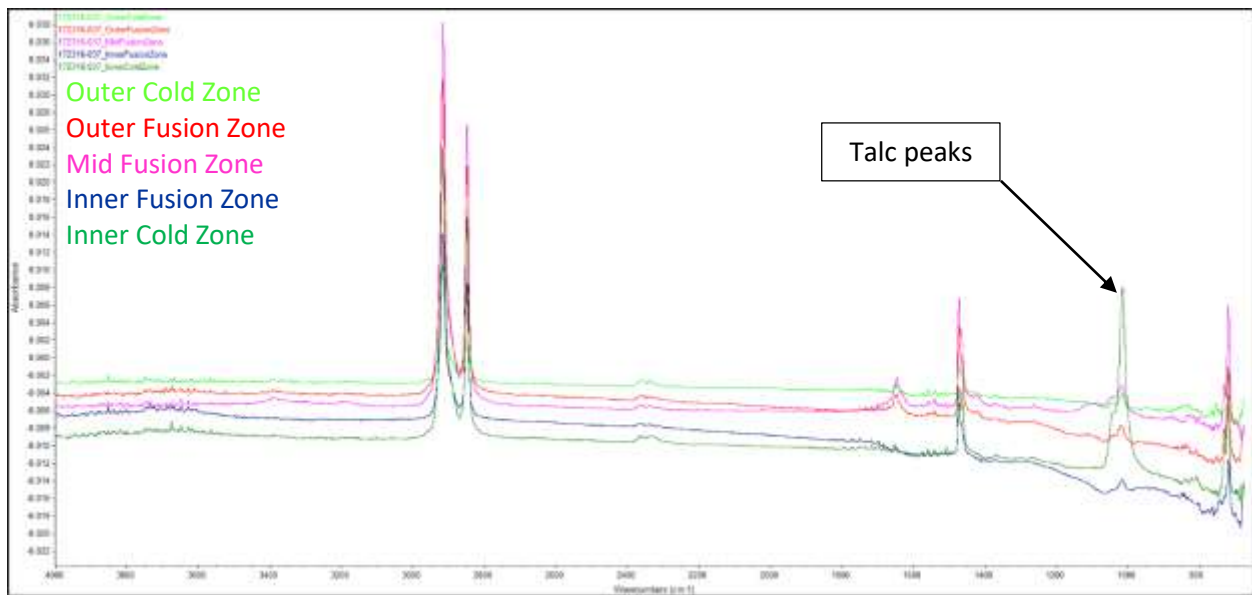

Figure 152. Sample 172316-037, FTIR spectra from decohesion test result

172316-038

172316-038	172395-018	Talc	91% Isopropanol	Cotton Cloth Rag
------------	------------	------	-----------------	------------------

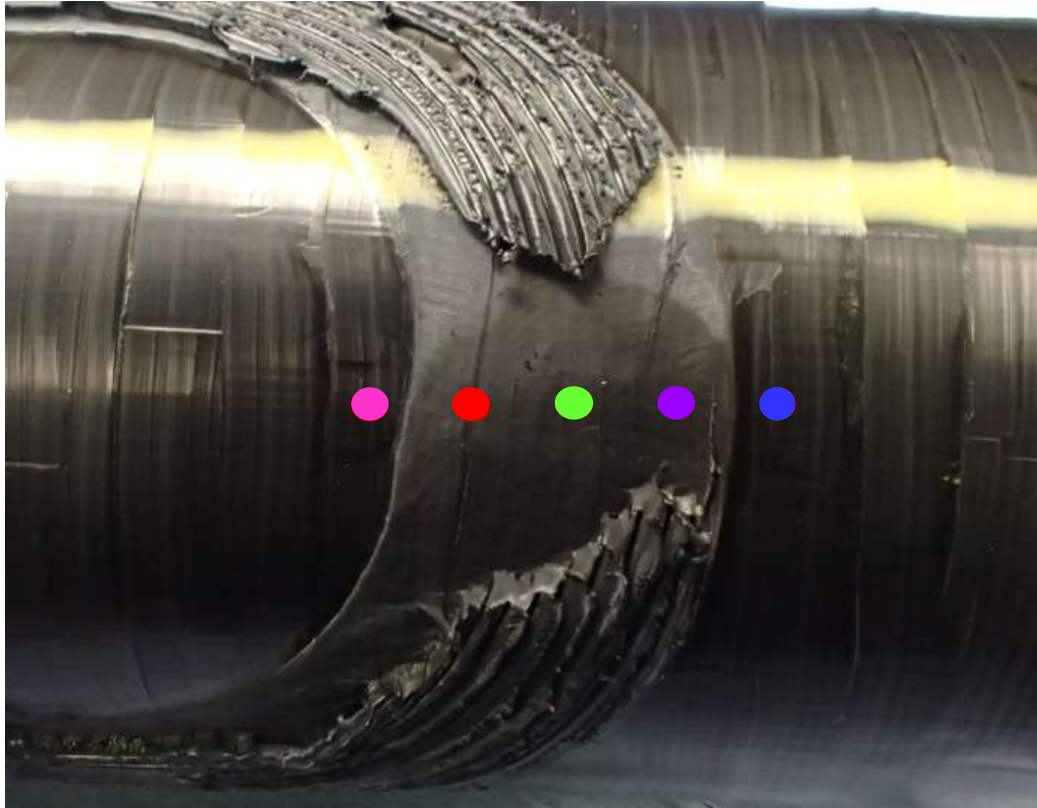

Figure 153. Sample 172316-038, decohesion test result

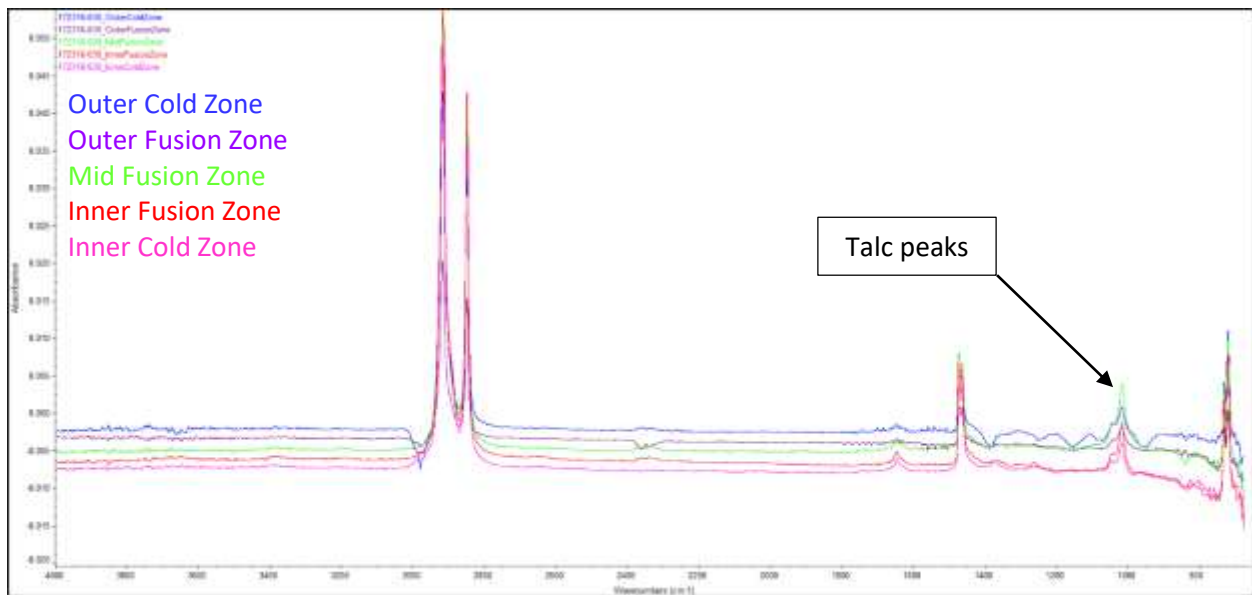

Figure 154. Sample 172316-038, FTIR spectra from decohesion test result

172316-041

172316-041	172395-021	Talc	91% Isopropanol	Lint-Free Wipe
------------	------------	------	-----------------	----------------

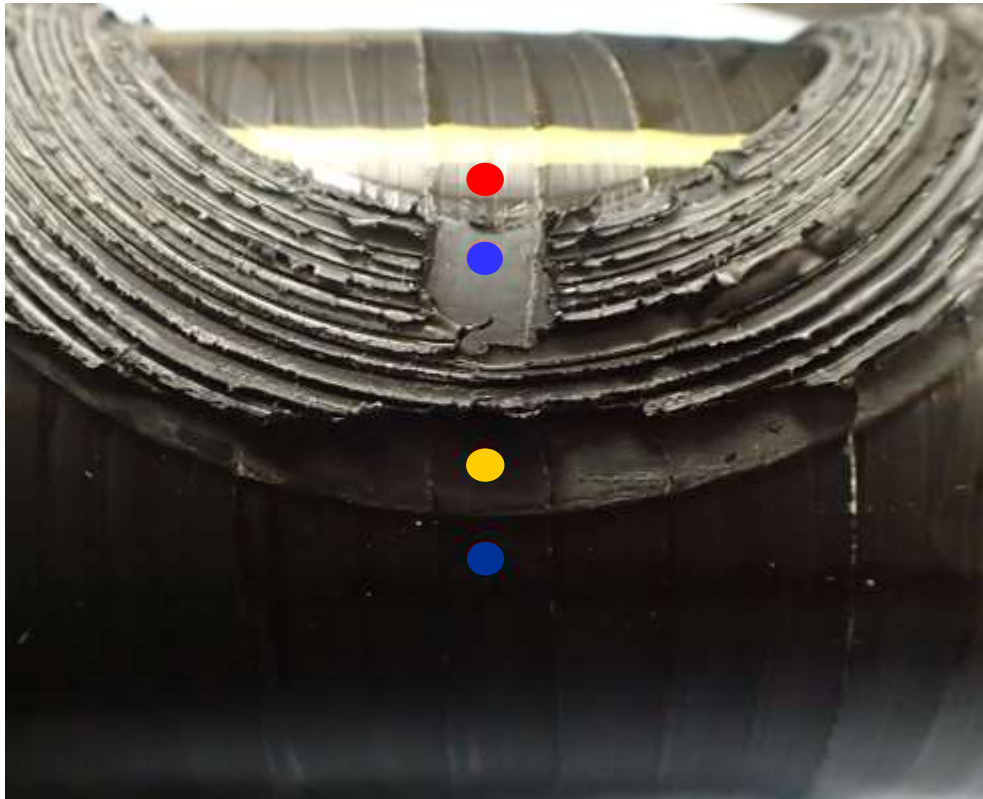

Figure 155. Sample 172316-041, decohesion test result

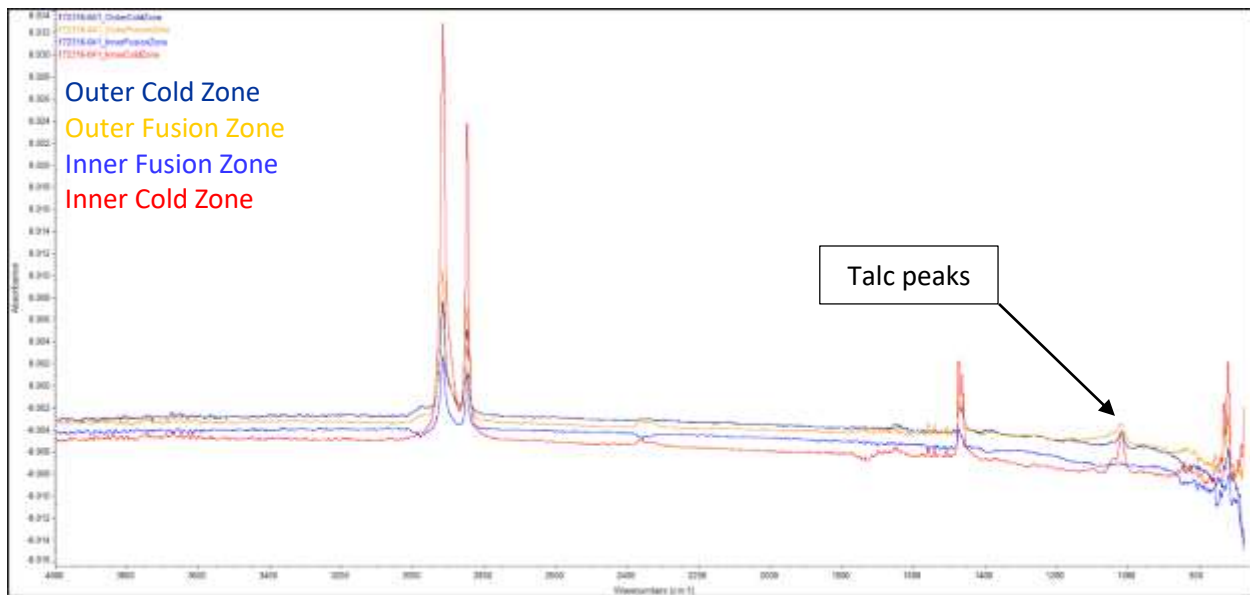

Figure 156. Sample 172316-041, FTIR spectra from decohesion test result

172316-042

172316-042	172395-023	Talc	91% Isopropanol	Paper Towel
------------	------------	------	-----------------	-------------

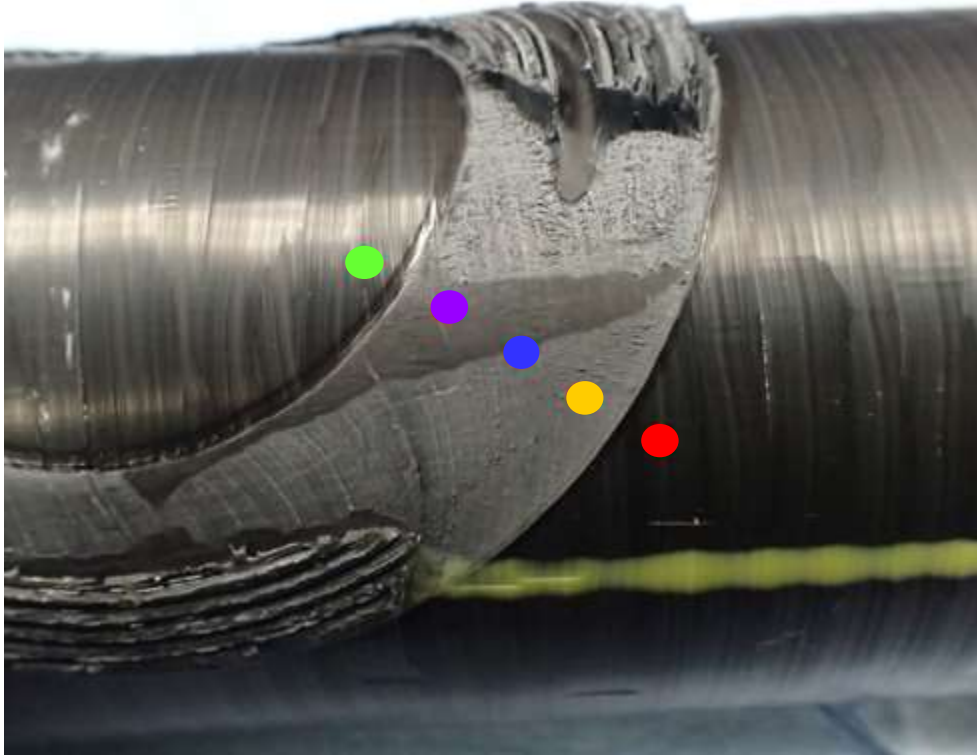

Figure 157. Sample 172316-042, decohesion test result

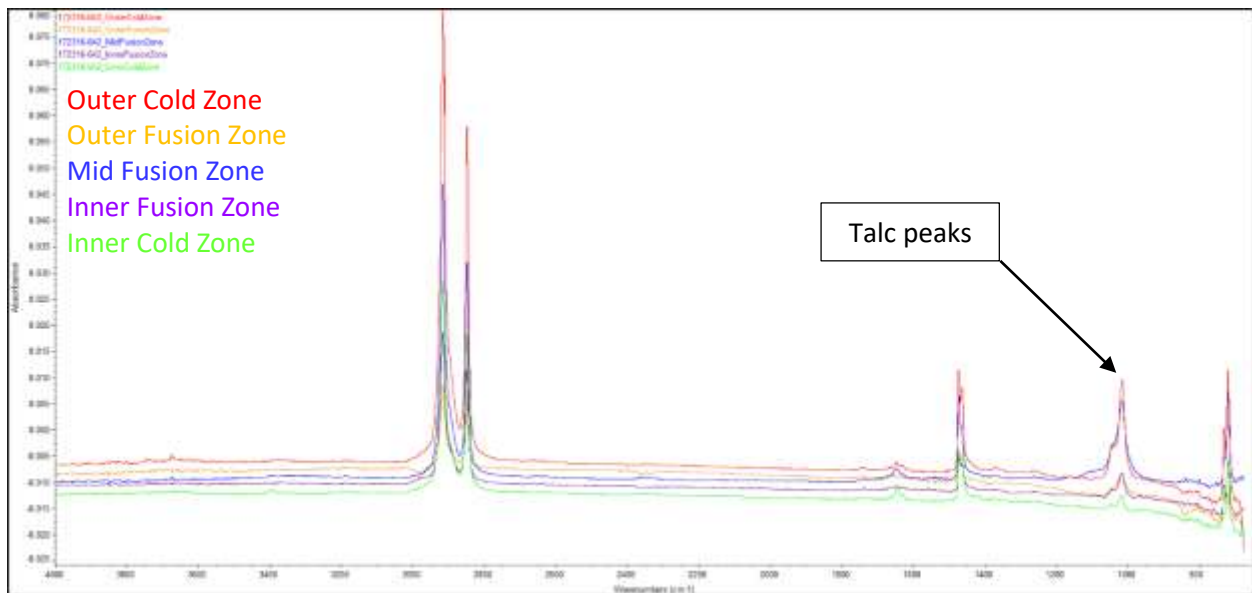

Figure 158. Sample 172316-042, FTIR spectra from decohesion test result

172316-044

172316-044	172395-027	Talc	Acetone	Lint-Free Wipe
------------	------------	------	---------	----------------

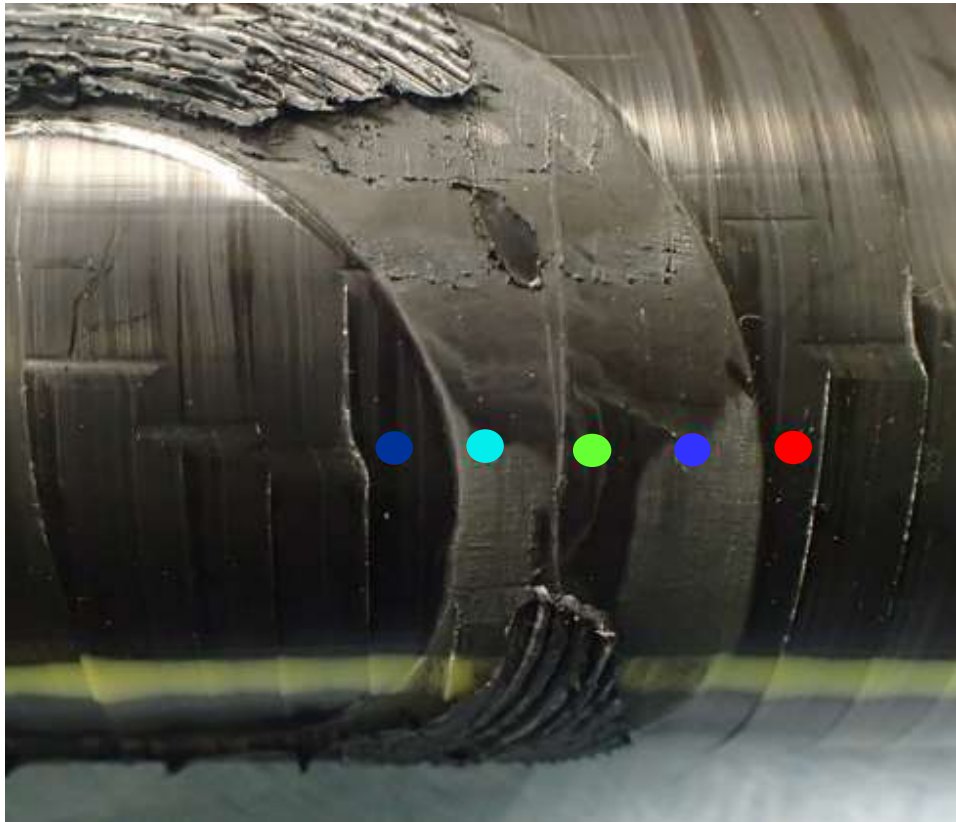

Figure 159. Sample 172316-044, decohesion test result

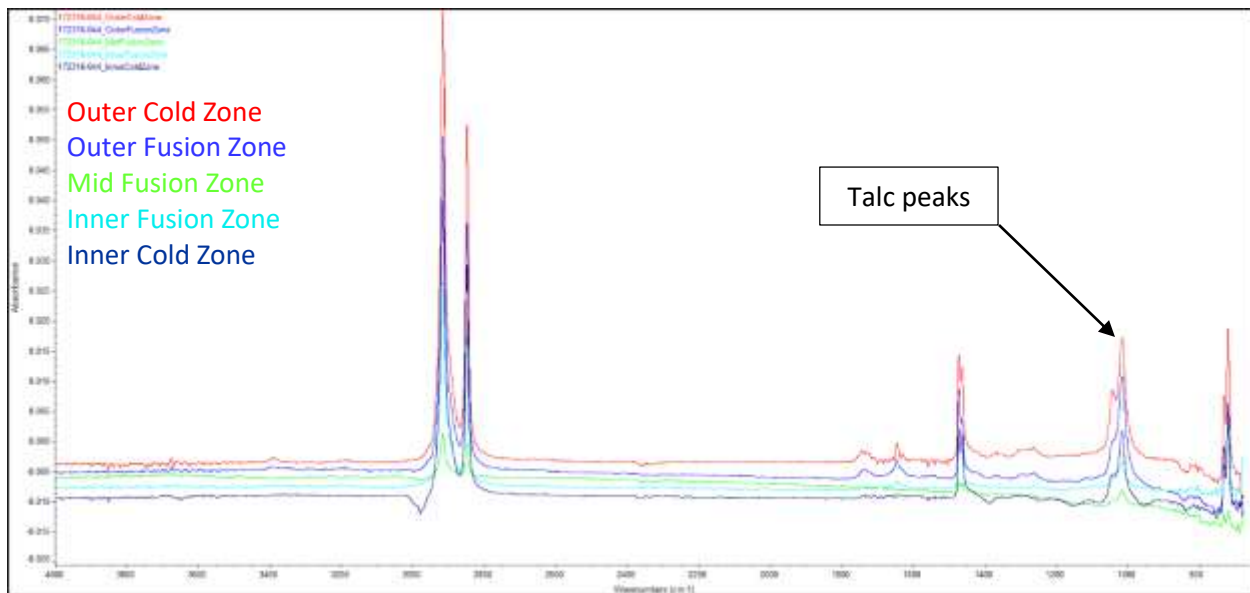

Figure 160. Sample 172316-044, FTIR spectra from decohesion test result

172316-045

172316-045	172395-028	Talc	Acetone	Lint-Free Wipe
------------	------------	------	---------	----------------

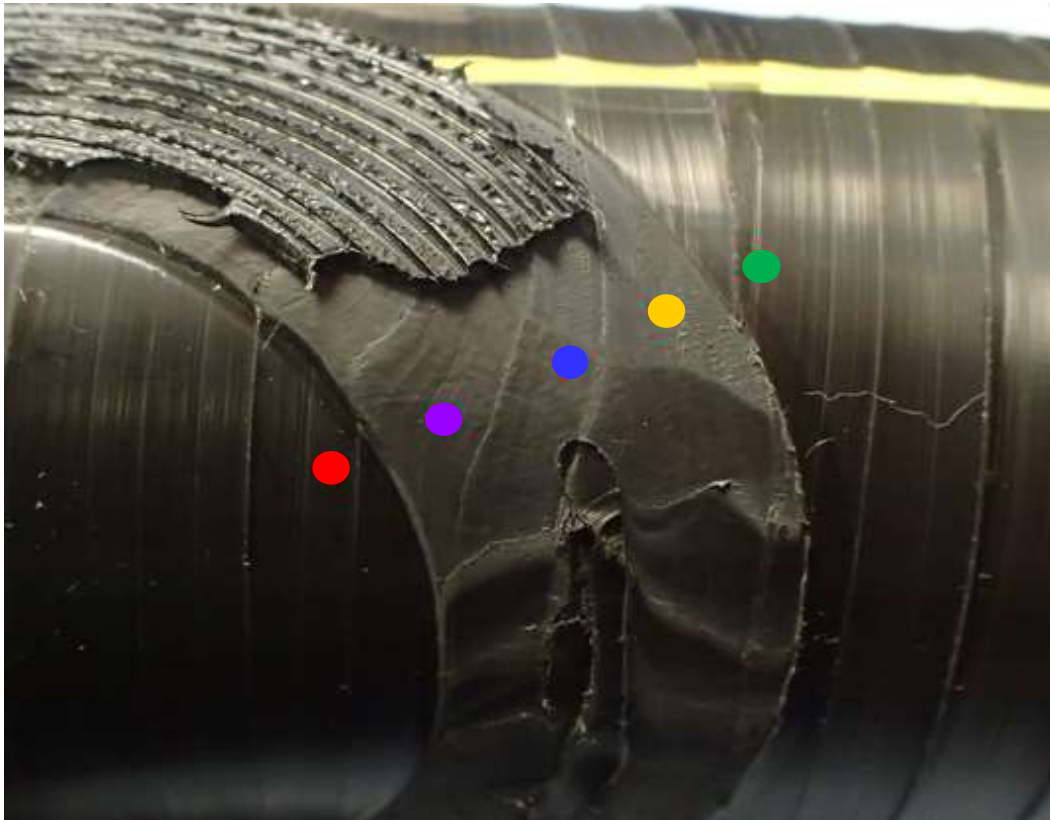

Figure 161. Sample 172316-045, decohesion test result

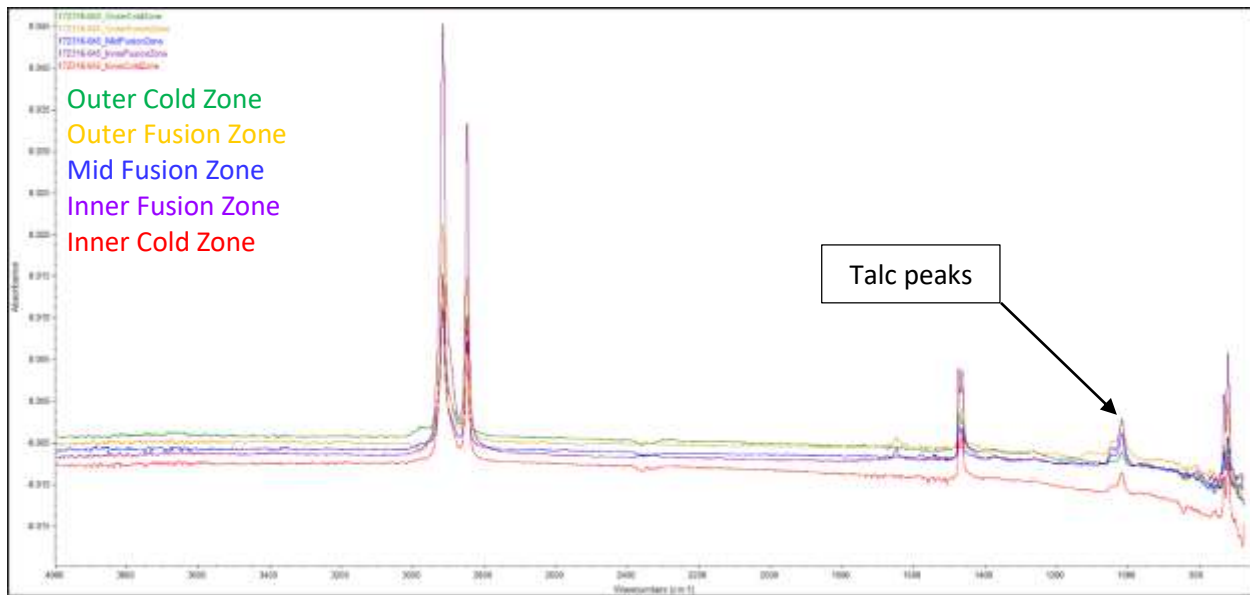

Figure 162. Sample 172316-045, FTIR spectra from decohesion test result

172316-046

172316-046	172395-031	Talc	Acetone	Cotton Cloth Rag
------------	------------	------	---------	------------------

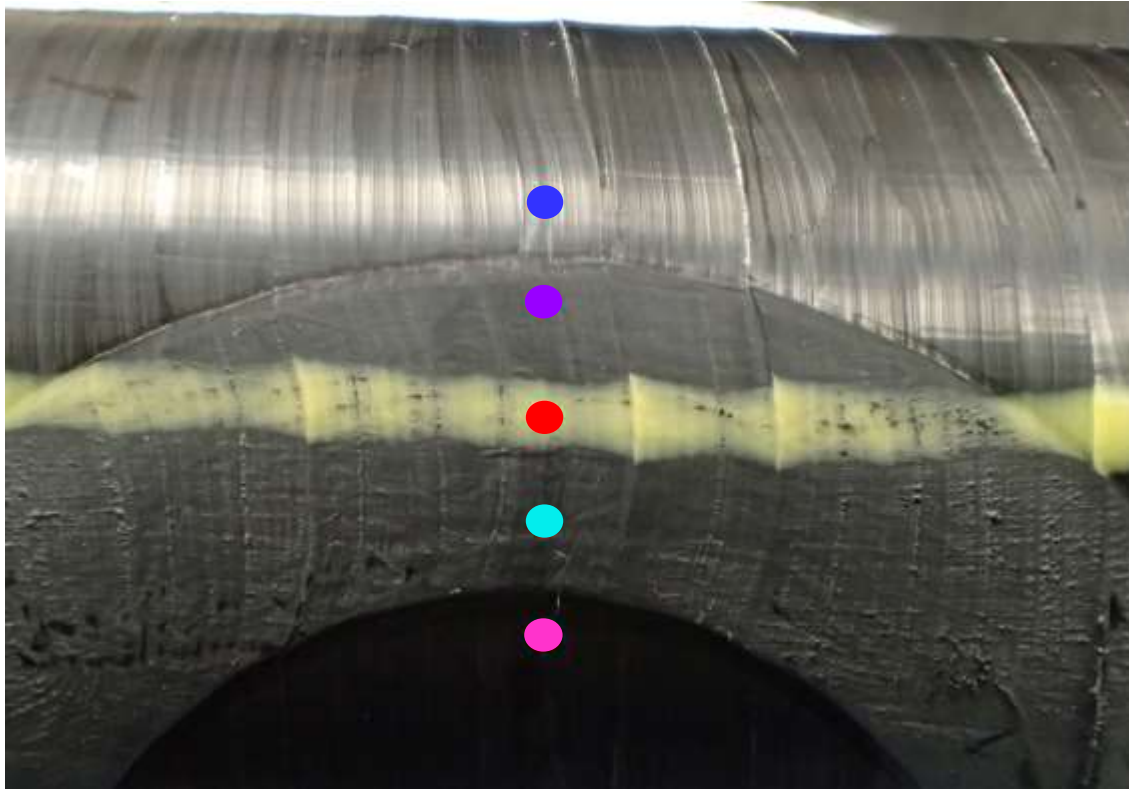

Figure 163. Sample 172316-046, decohesion test result

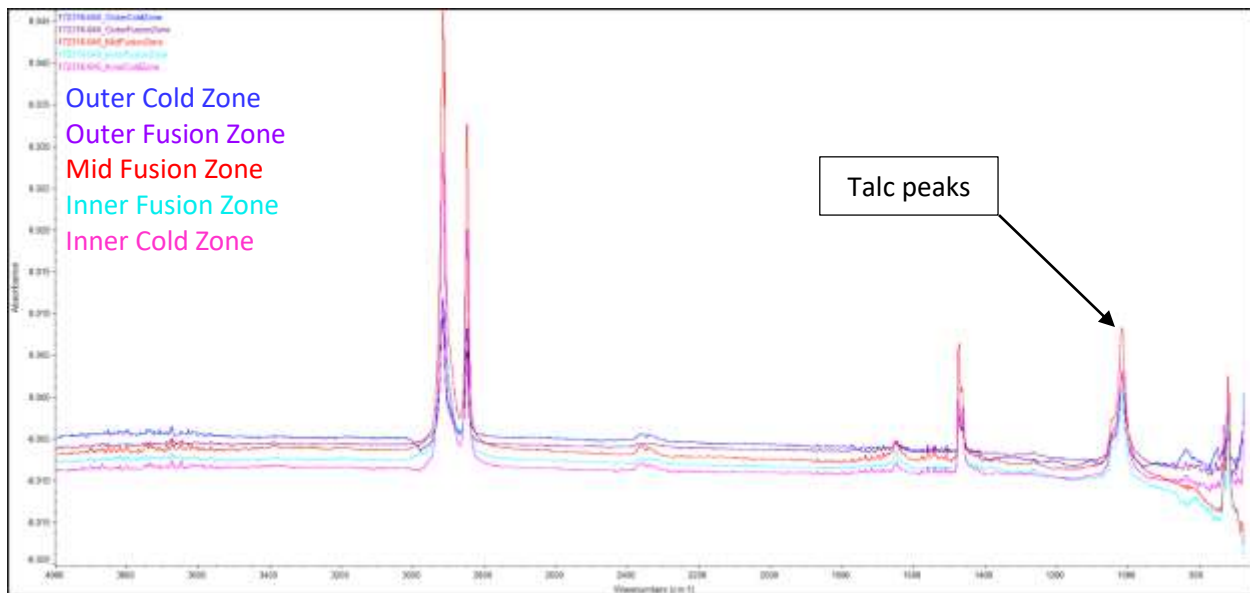

Figure 164. Sample 172316-046, FTIR spectra from decohesion test result

172316-047

172316-047	172395-032	Talc	Acetone	Cotton Cloth Rag
------------	------------	------	---------	------------------

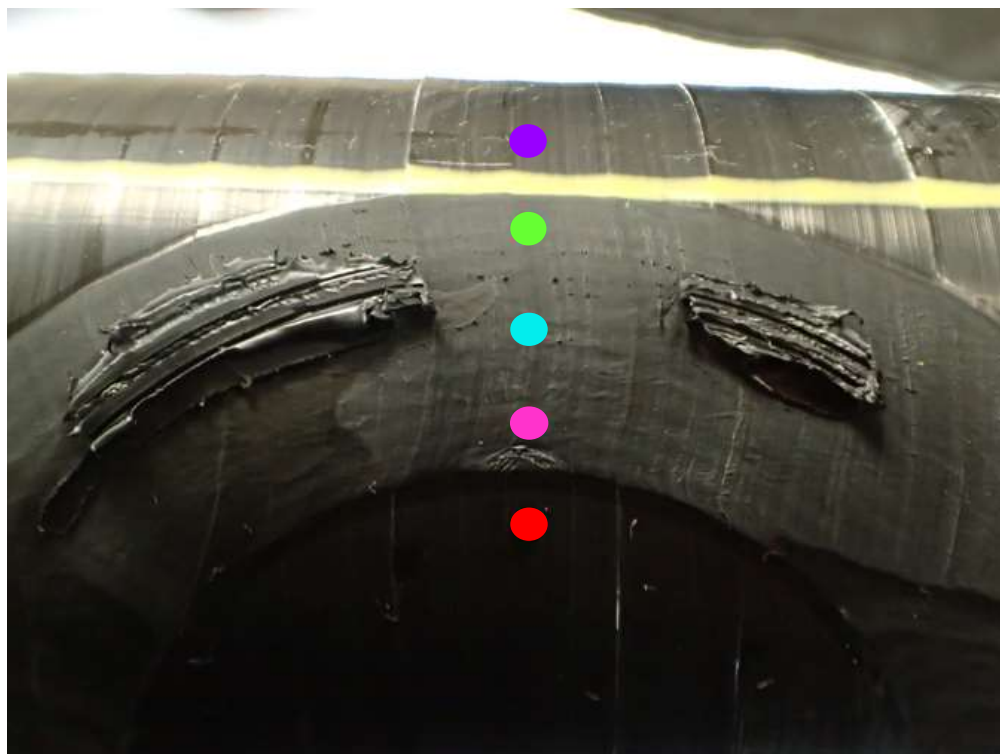

Figure 165. Sample 172316-047, decohesion test result

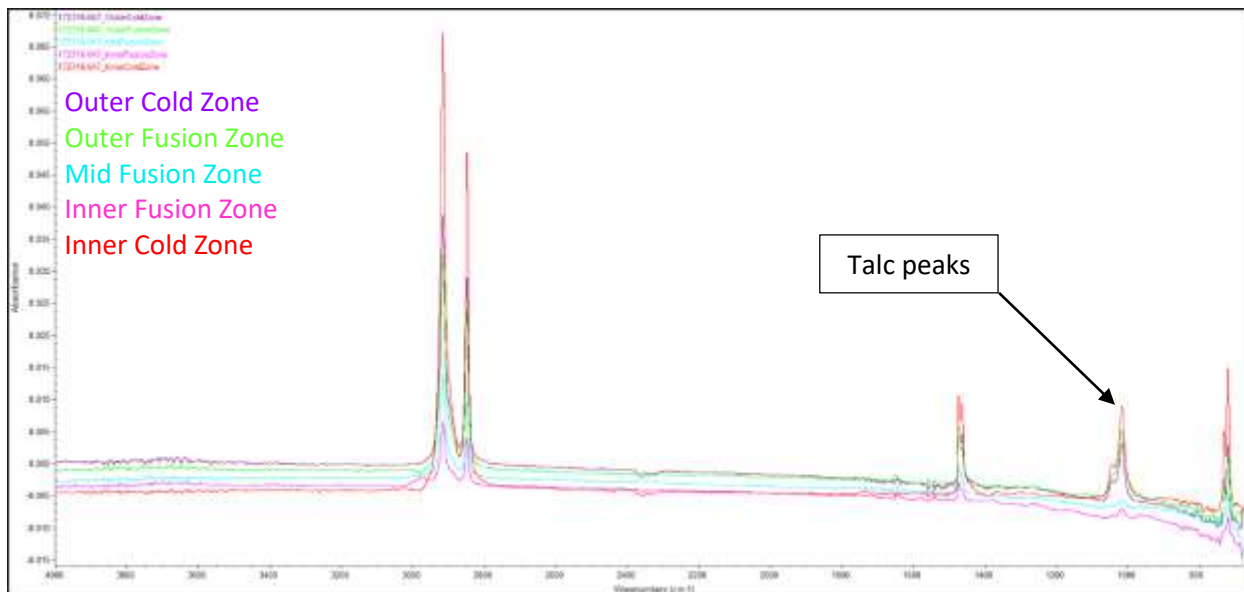

Figure 166. Sample 172316-047, FTIR spectra from decohesion test result

172316-048

172316-048	172395-035	Talc	Acetone	Paper Towel
------------	------------	------	---------	-------------



Figure 167. Sample 172316-048, decohesion test result

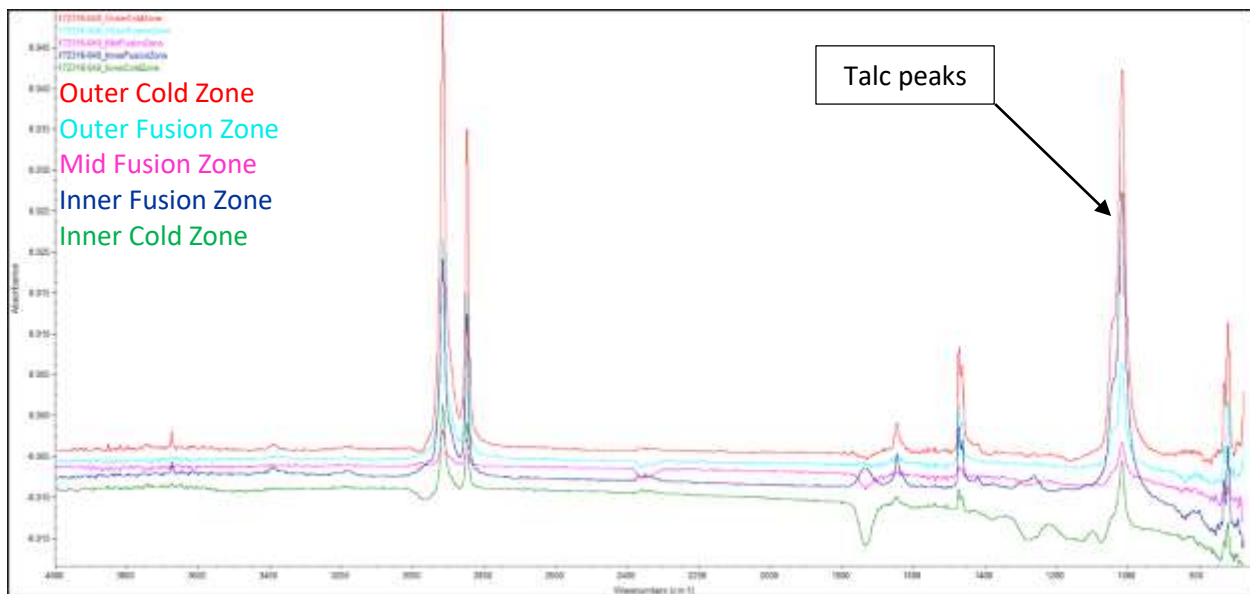

Figure 168. Sample 172316-048, FTIR spectra from decohesion test result

172316-049

172316-049	172395-036	Talc	Acetone	Paper Towel
------------	------------	------	---------	-------------

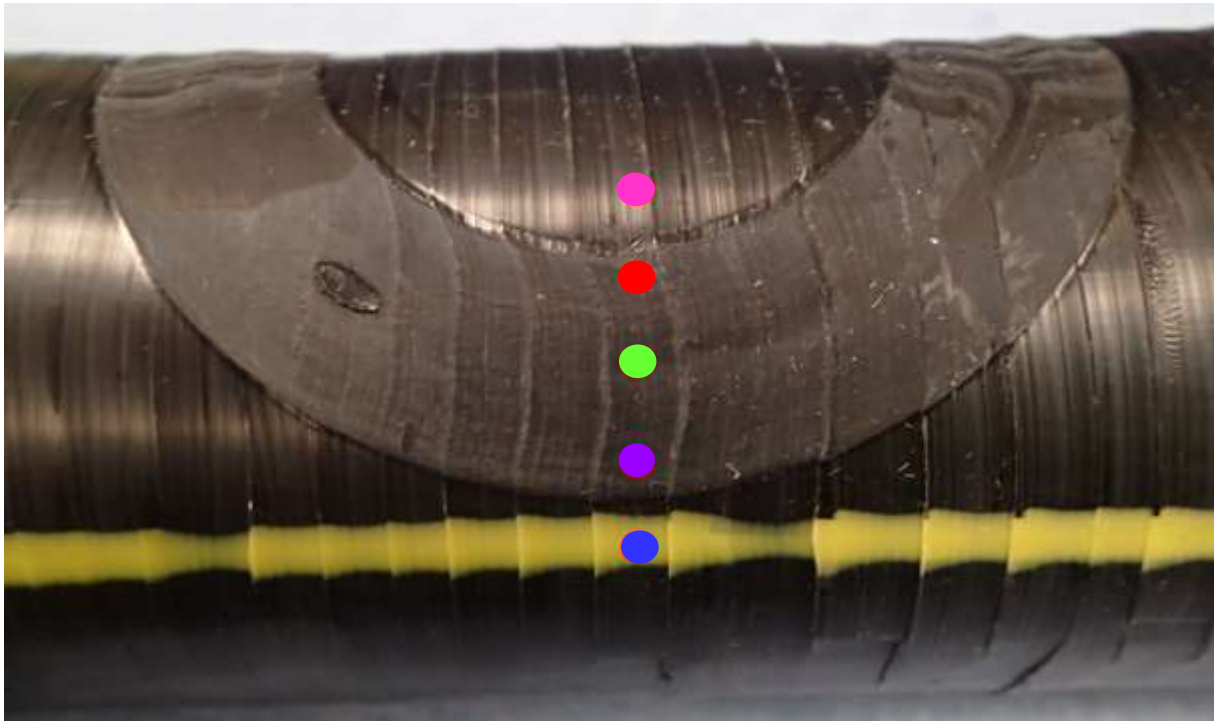

Figure 169. Sample 172316-049, decohesion test result

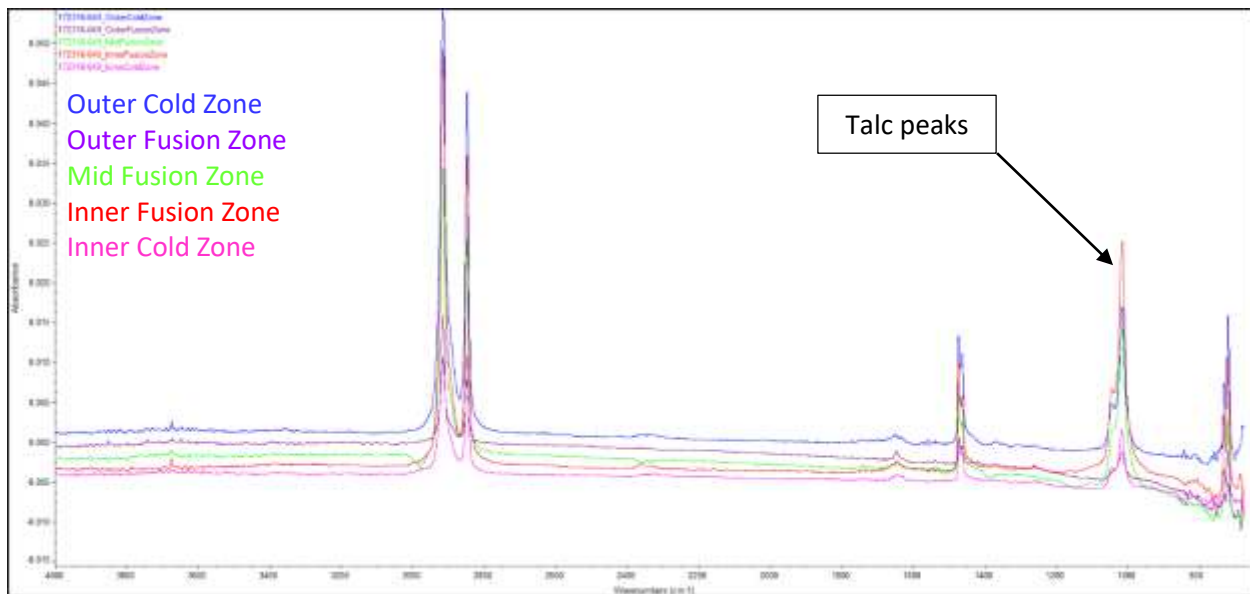

Figure 170. Sample 172316-049, FTIR spectra from decohesion test result

172316-050

172316-050	172395-039	Talc	None	None
------------	------------	------	------	------

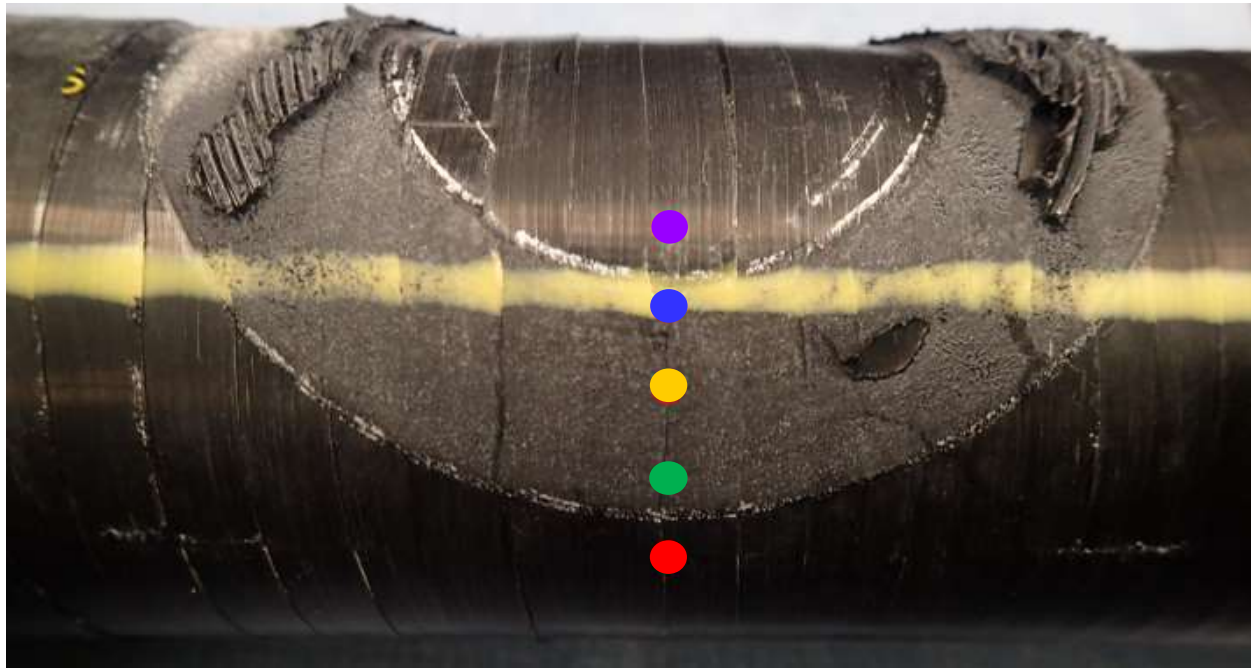

Figure 171. Sample 172316-050, decohesion test result

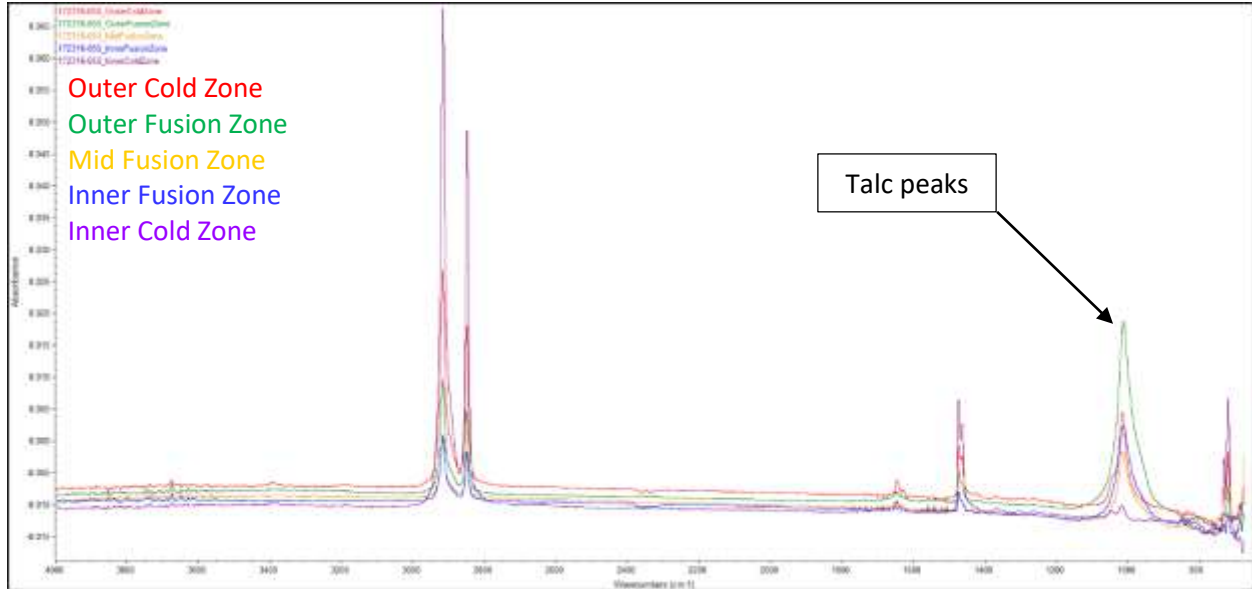

Figure 172. Sample 172316-050, FTIR spectra from decohesion test result

172316-051

172316-051	172395-040	Talc	None	None
------------	------------	------	------	------

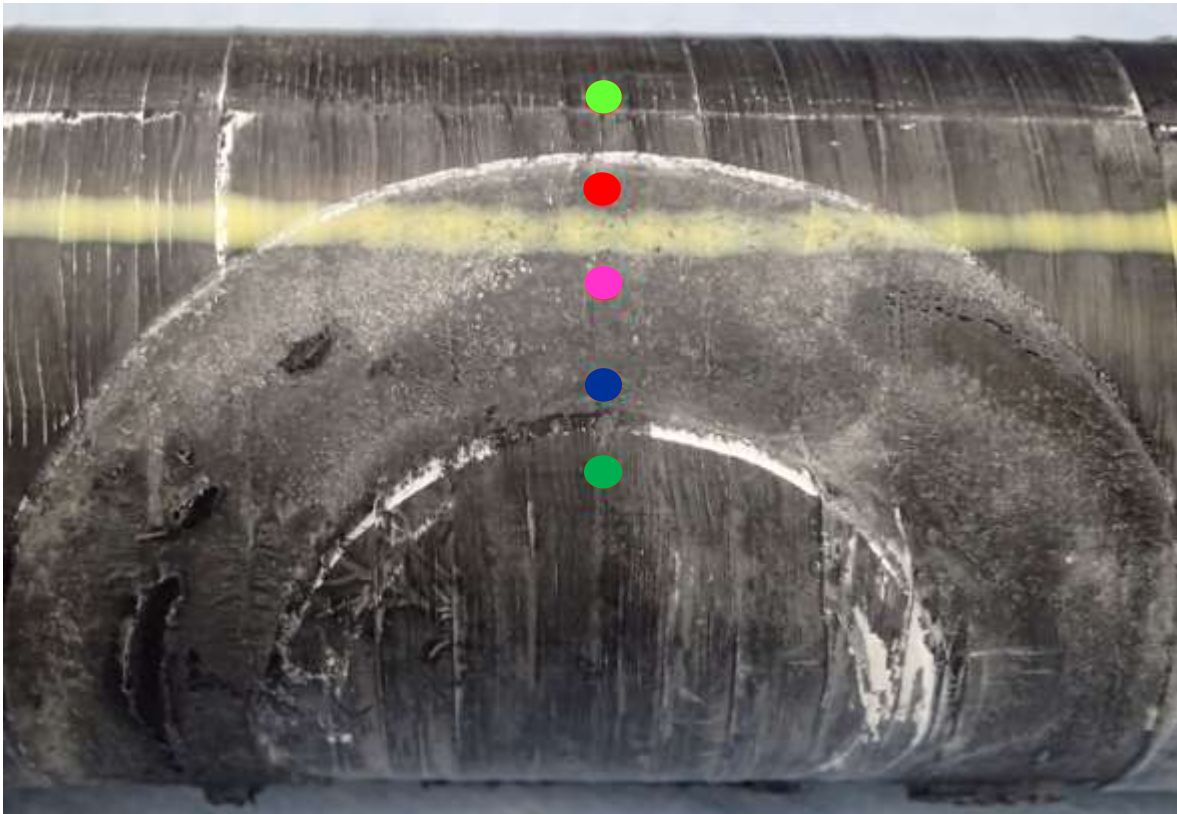

Figure 173. Sample 172316-051, decohesion test result

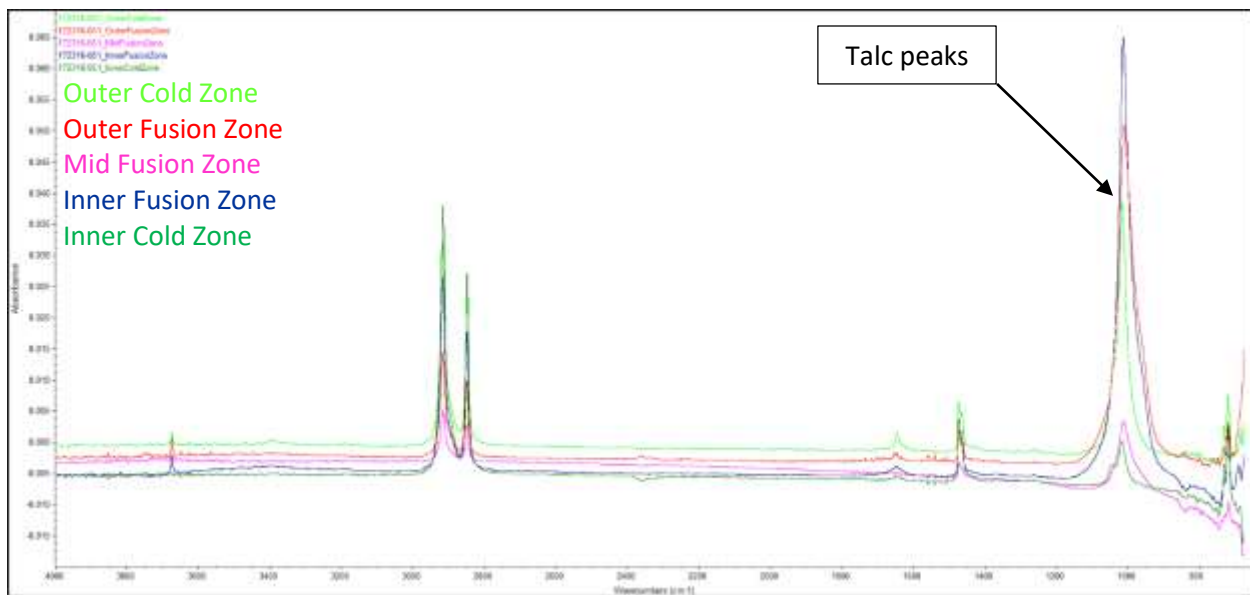

Figure 174. Sample 172316-051, FTIR spectra from decohesion test result

172316-052

172316-052	172395-043	Bentonite	99% Isopropanol	Lint-Free Wipe
------------	------------	-----------	-----------------	----------------

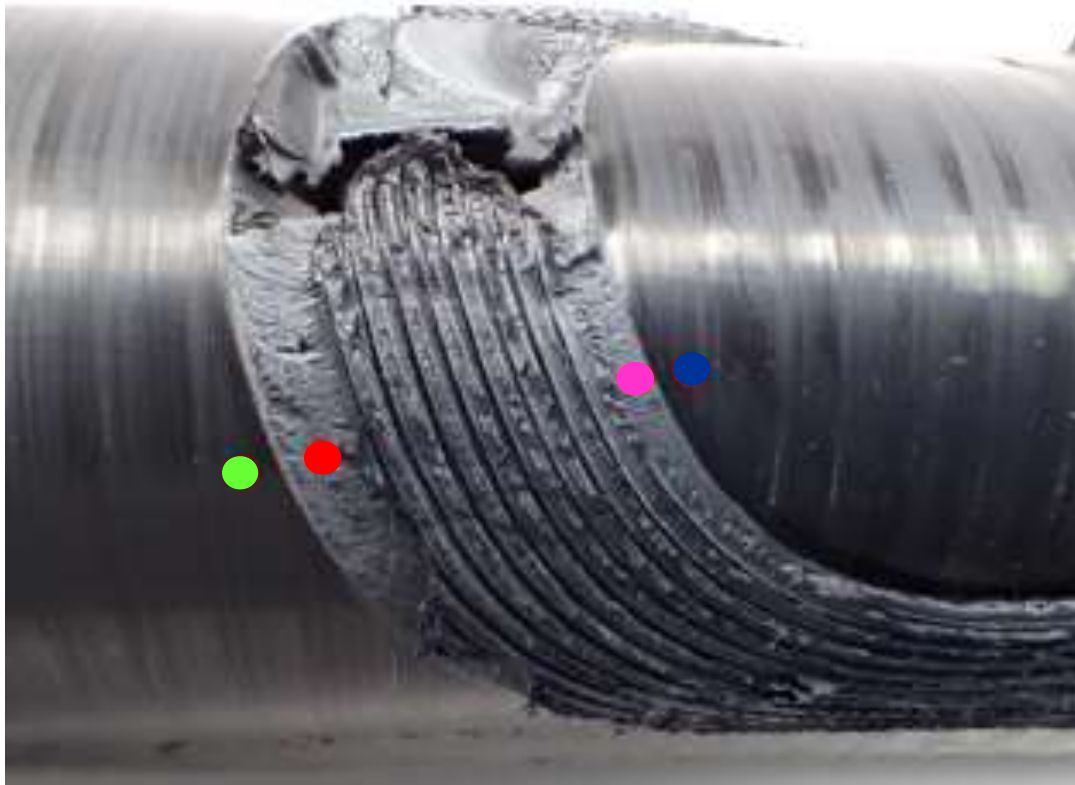

Figure 175. Sample 172316-052, decohesion test result

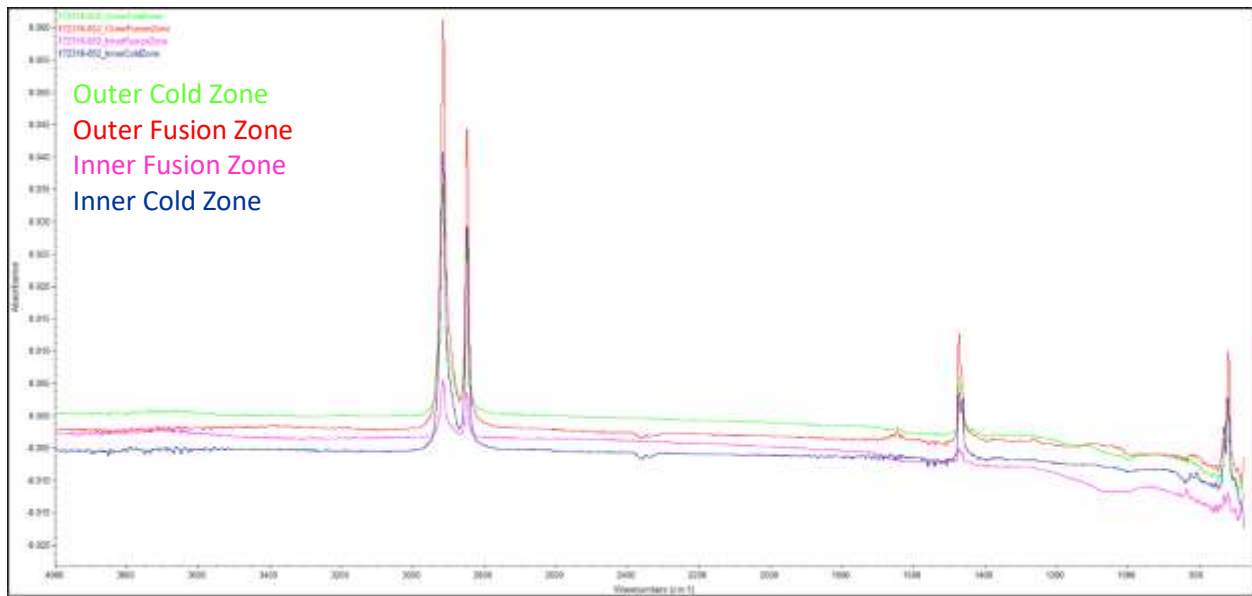

Figure 176. Sample 172316-052, FTIR spectra from decohesion test result

172316-053

172316-053	172395-044	Bentonite	99% Isopropanol	Lint-Free Wipe
------------	------------	-----------	-----------------	----------------

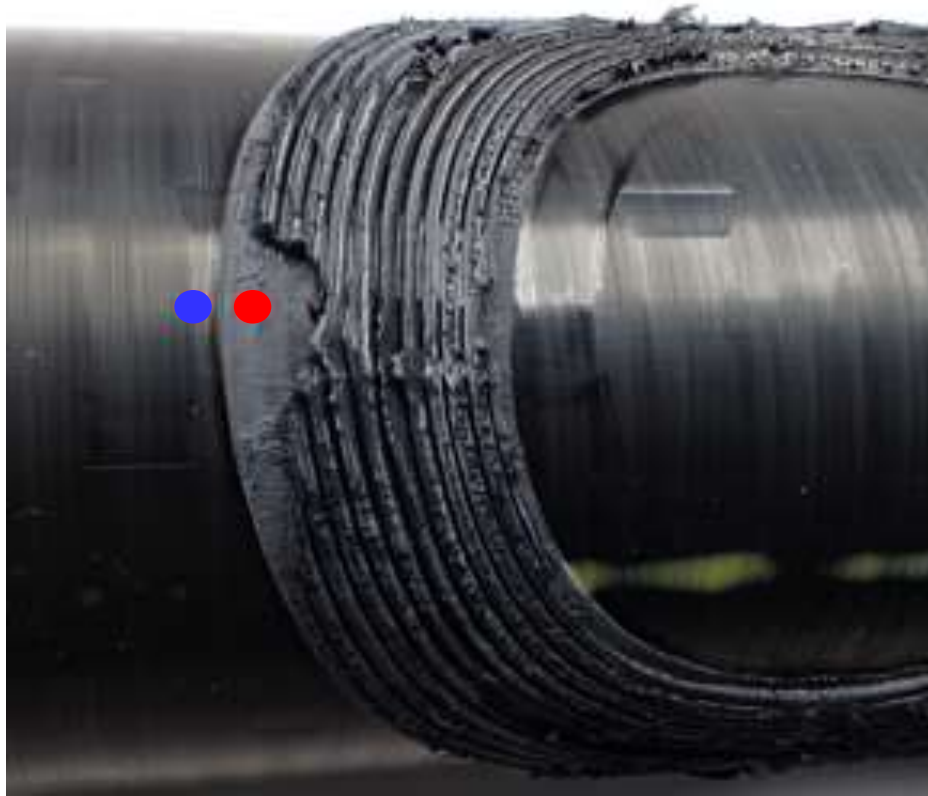

Figure 177. Sample 172316-053, decohesion test result

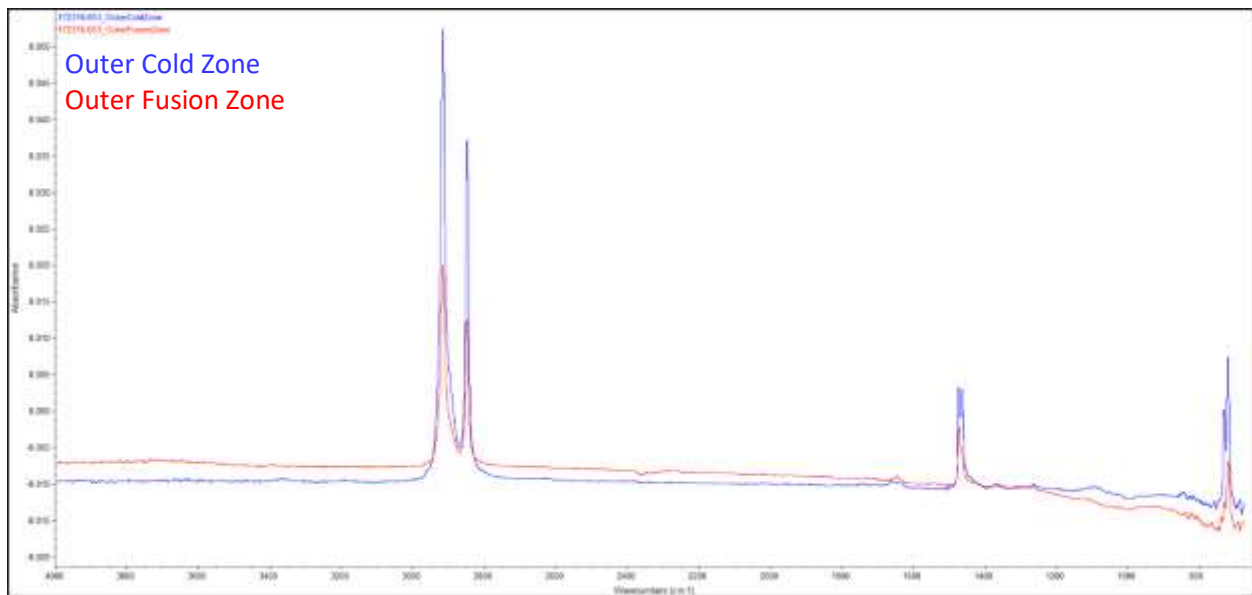

Figure 178. Sample 172316-053, FTIR spectra from decohesion test result

172316-054

172316-054	172395-047	Bentonite	99% Isopropanol	Cotton Cloth Rag
------------	------------	-----------	-----------------	------------------



Figure 179. Sample 172316-054, decohesion test result

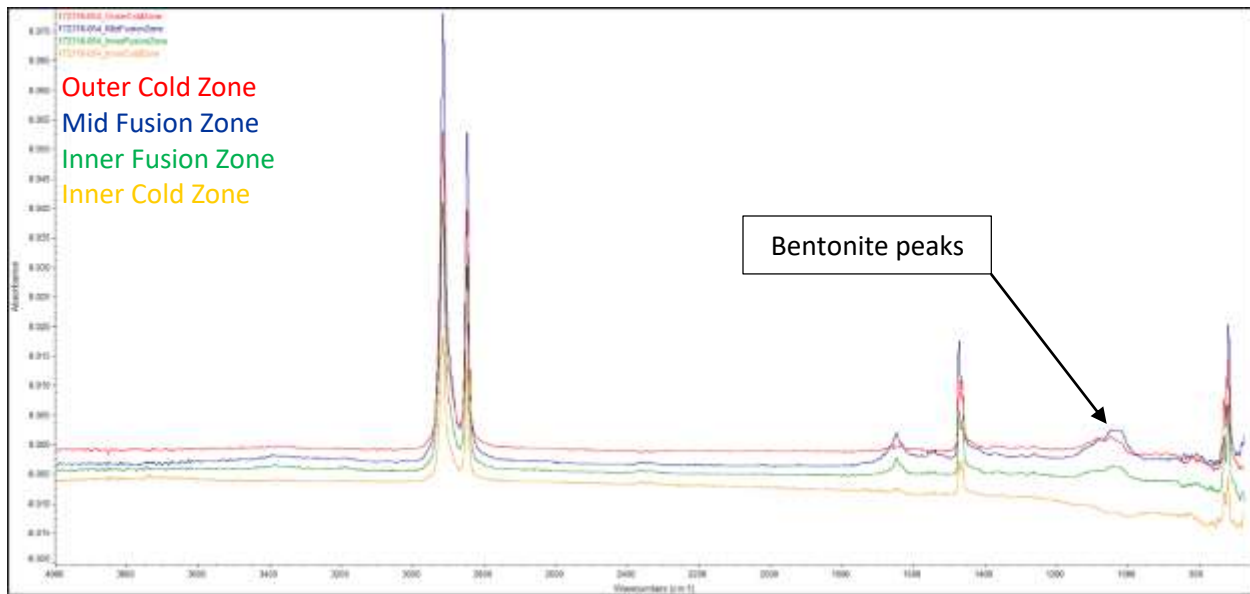

Figure 180. Sample 172316-054, FTIR spectra from decohesion test result

172316-055

172316-055	172395-048	Bentonite	99% Isopropanol	Cotton Cloth Rag
------------	------------	-----------	-----------------	------------------

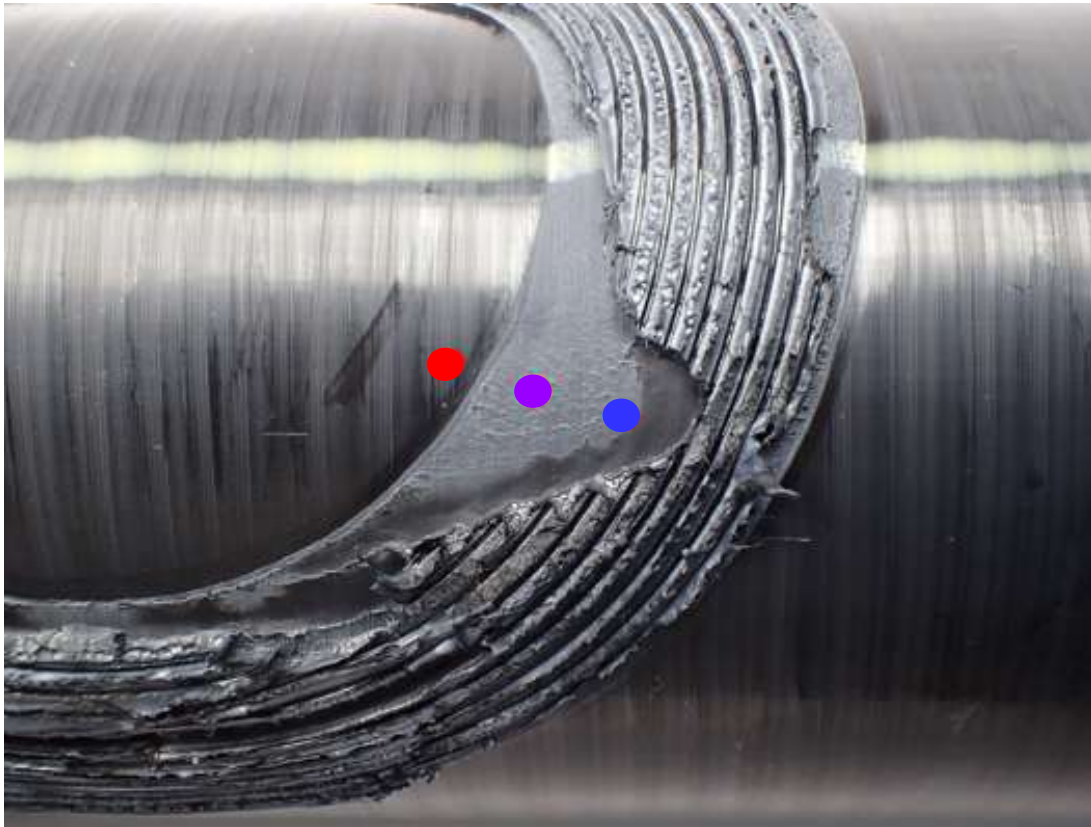

Figure 181. Sample 172316-055, decohesion test result

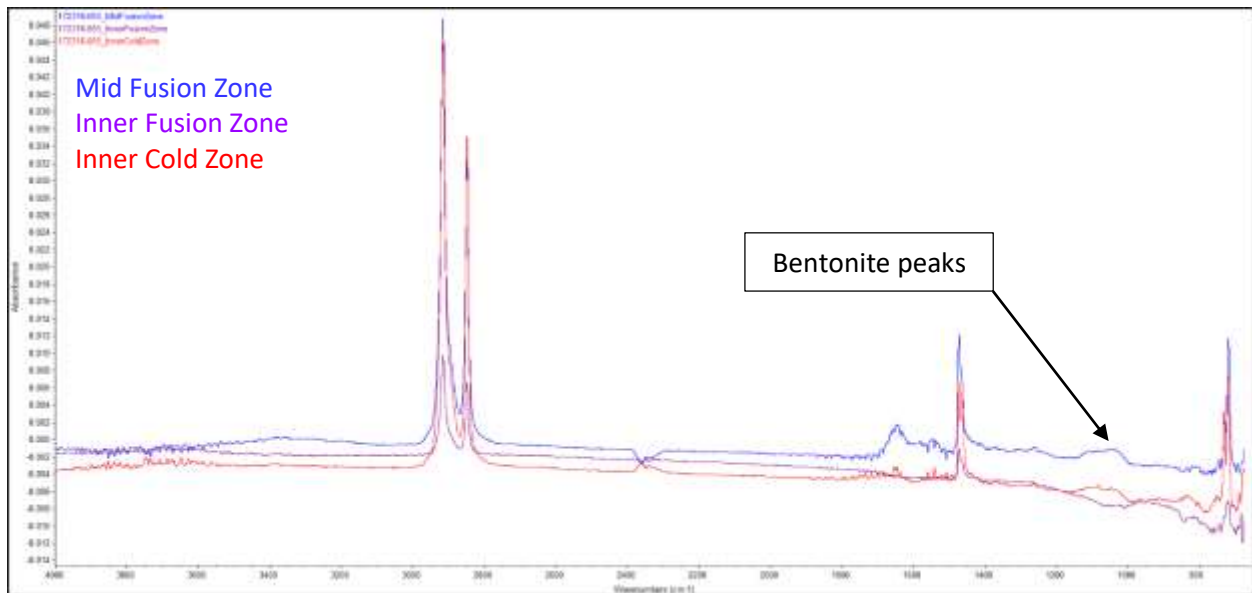

Figure 182. Sample 172316-055, FTIR spectra from decohesion test result

172316-057

172316-057	172395-052	Bentonite	99% Isopropanol	Paper Towel
------------	------------	-----------	-----------------	-------------

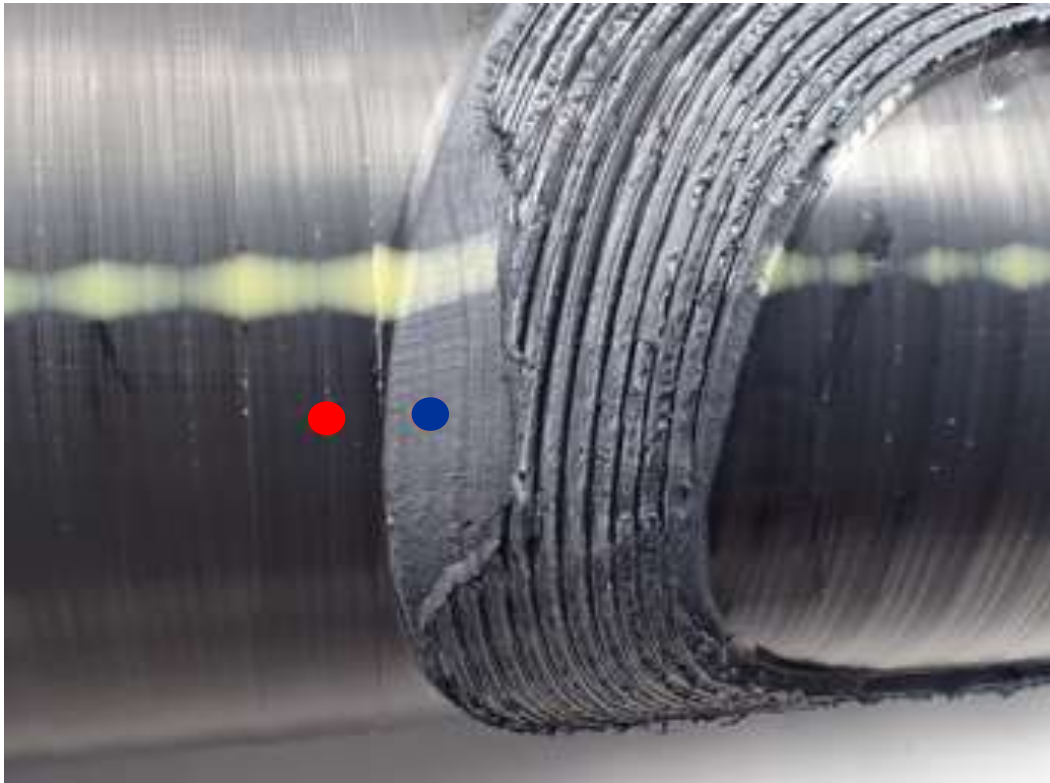

Figure 183. Sample 172316-057, decohesion test result

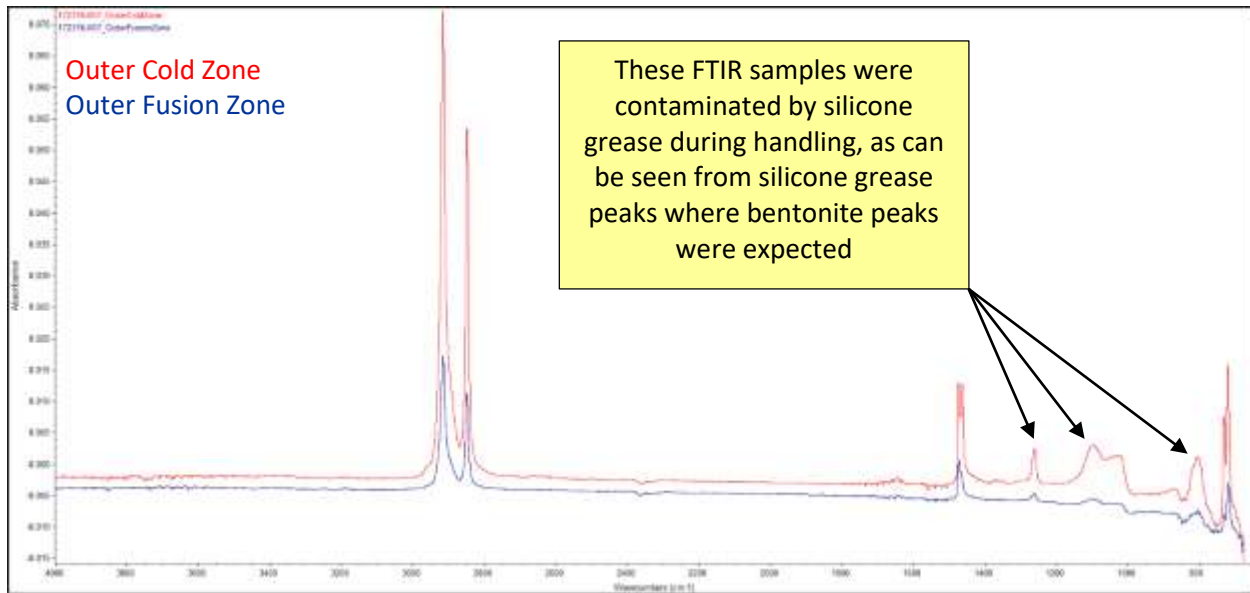

Figure 184. Sample 172316-057, FTIR spectra from decohesion test result

172316-058

172316-058	172395-055	Bentonite	91% Isopropanol	Lint-Free Wipe
------------	------------	-----------	-----------------	----------------



Figure 185. Sample 172316-058, decohesion test result

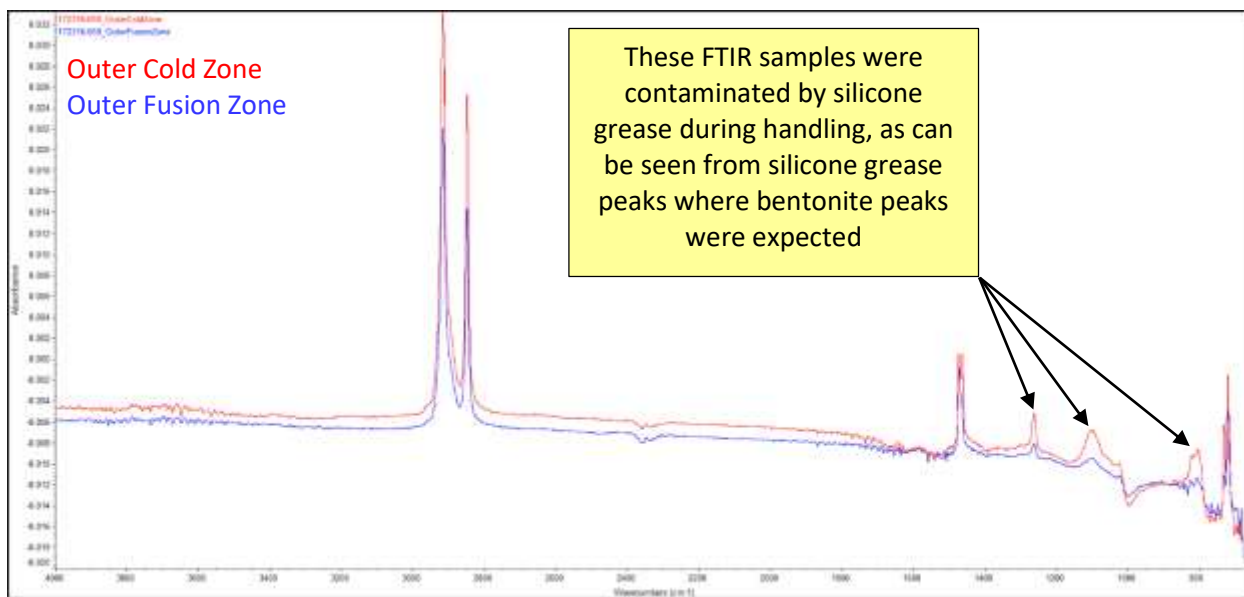

Figure 186. Sample 172316-058, FTIR spectra from decohesion test result

172316-059

172316-059	172395-056	Bentonite	91% Isopropanol	Lint-Free Wipe
------------	------------	-----------	-----------------	----------------

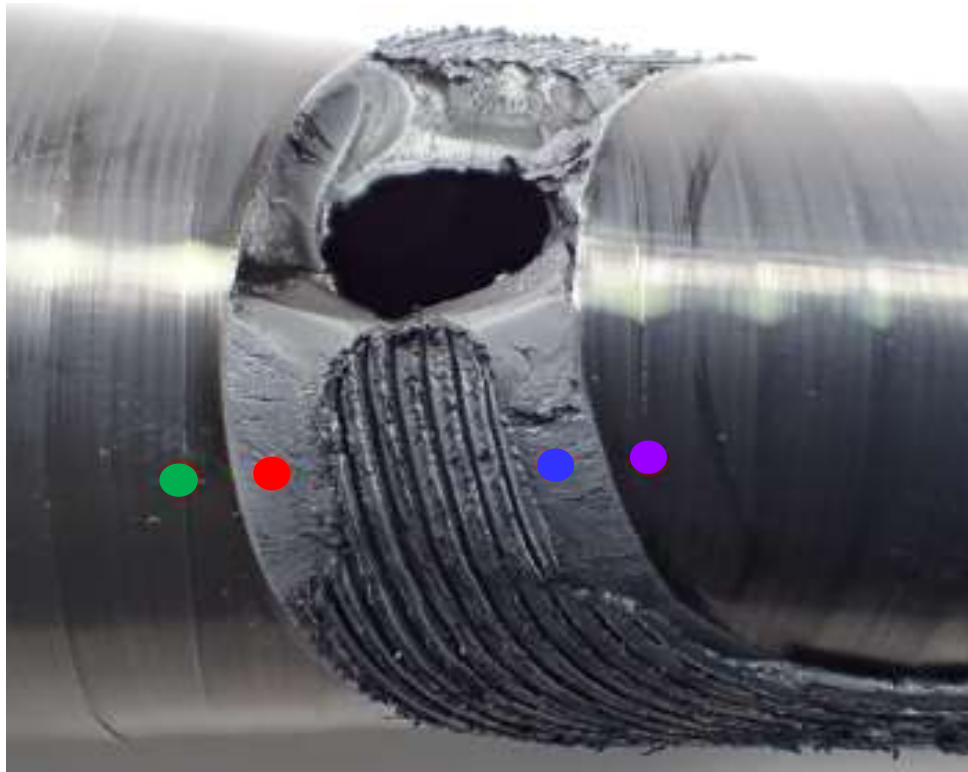

Figure 187. Sample 172316-059, decohesion test result

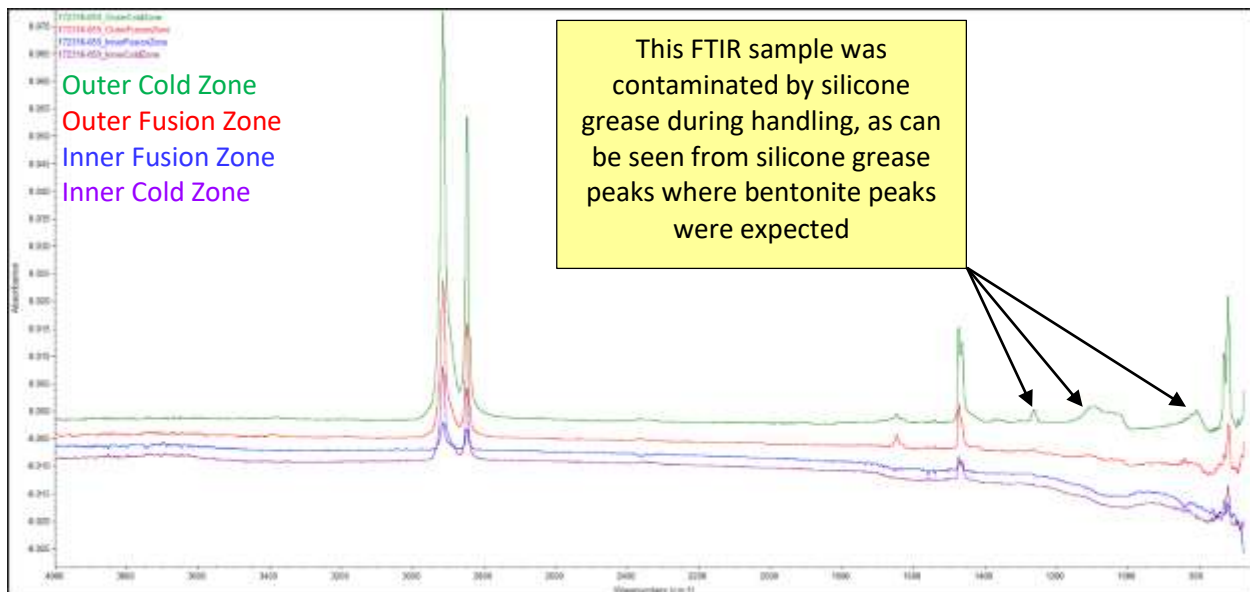

Figure 188. Sample 172316-059, FTIR spectra from decohesion test result

172316-060

172316-060	172395-059	Bentonite	91% Isopropanol	Cotton Cloth Rag
------------	------------	-----------	-----------------	------------------

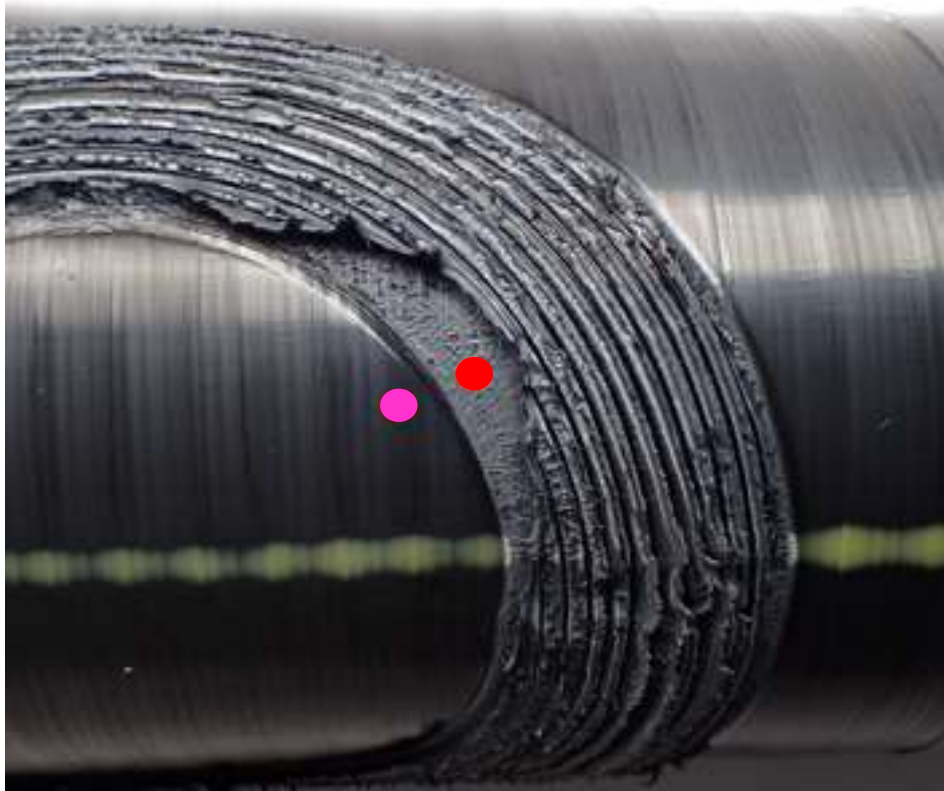

Figure 189. Sample 172316-060, decohesion test result

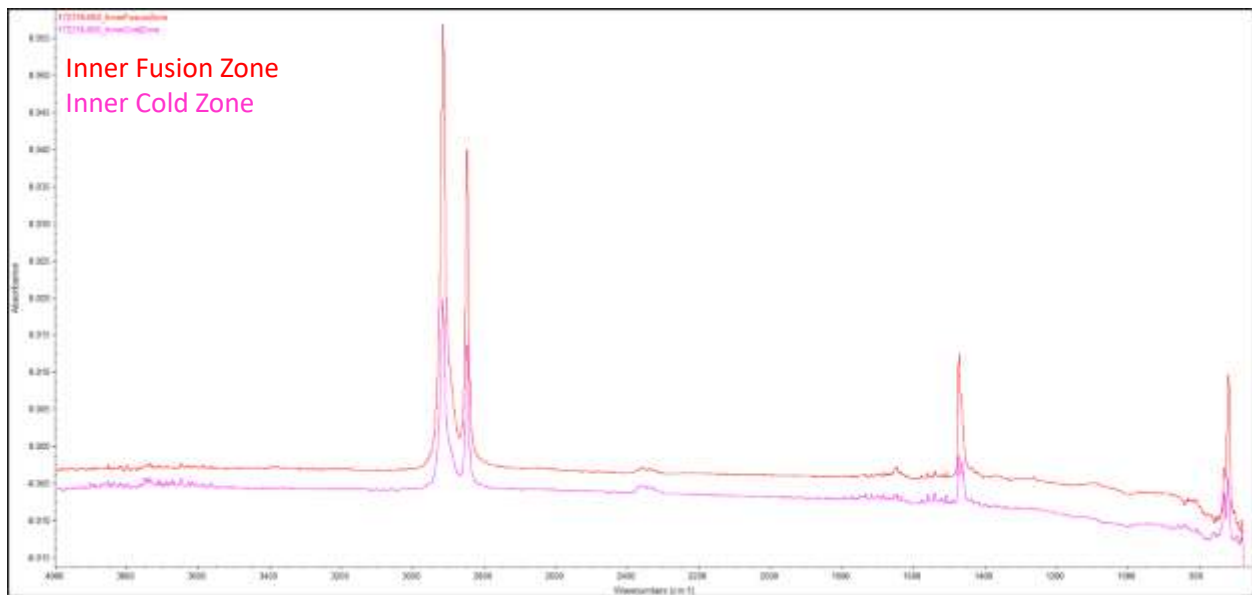

Figure 190. Sample 172316-060, FTIR spectra from decohesion test result

172316-061

172316-061	172395-060	Bentonite	91% Isopropanol	Cotton Cloth Rag
------------	------------	-----------	-----------------	------------------

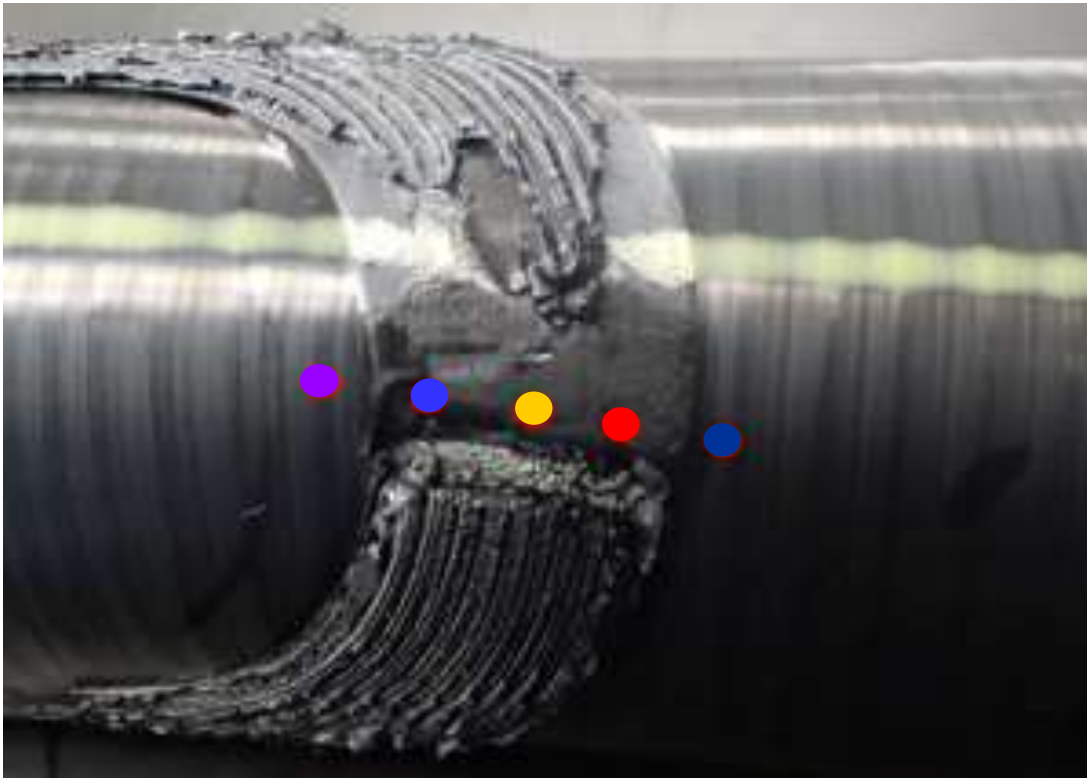

Figure 191. Sample 172316-061, decohesion test result

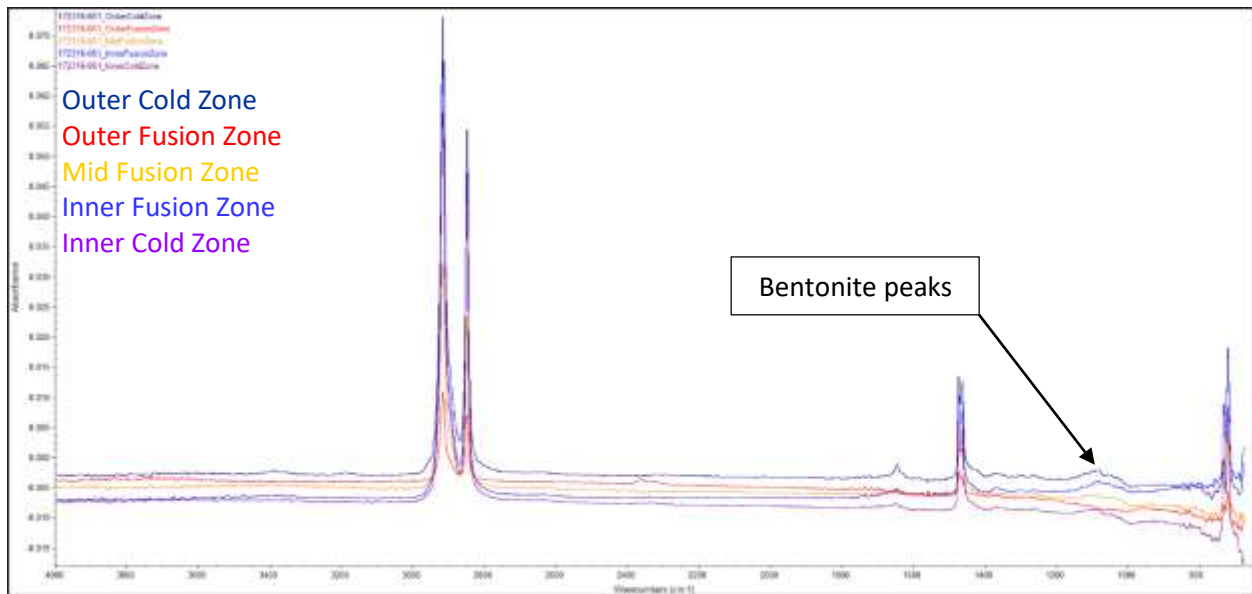

Figure 192. Sample 172316-061, FTIR spectra from decohesion test result

172316-063

172316-063	172395-064	Bentonite	91% Isopropanol	Paper Towel
------------	------------	-----------	-----------------	-------------

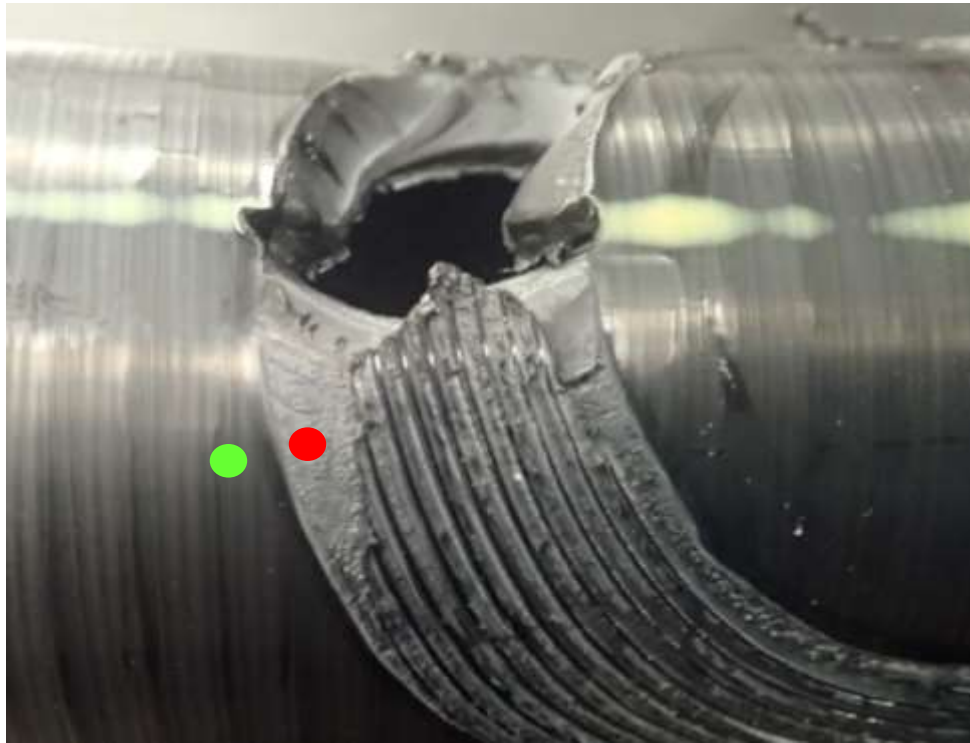

Figure 193. Sample 172316-063, decohesion test result

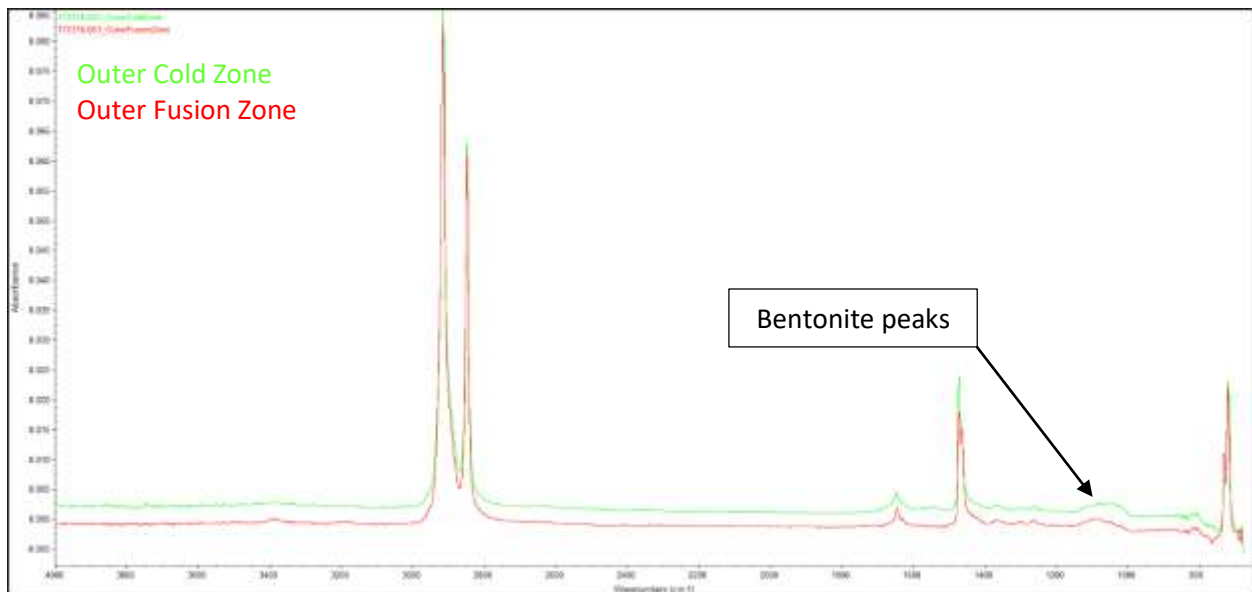

Figure 194. Sample 172316-063, FTIR spectra from decohesion test result

172316-064

172316-064	172395-067	Bentonite	Acetone	Lint-Free Wipe
------------	------------	-----------	---------	----------------



Figure 195. Sample 172316-064, decohesion test result

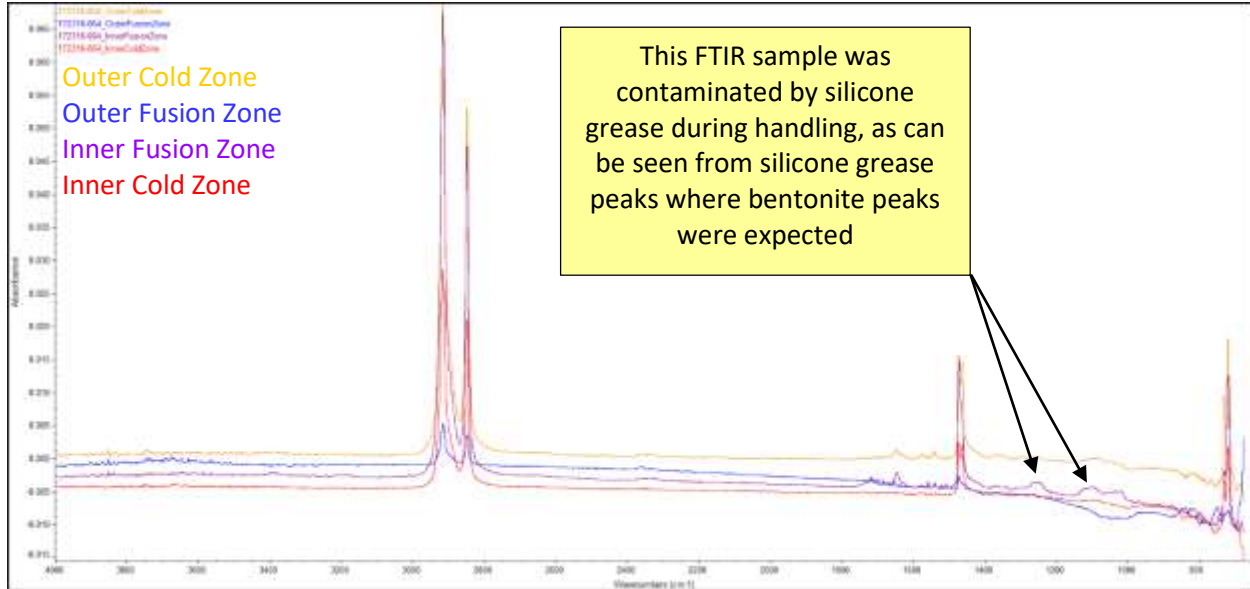

Figure 196. Sample 172316-064, FTIR spectra from decohesion test result

172316-065

172316-065	172395-068	Bentonite	Acetone	Lint-Free Wipe
------------	------------	-----------	---------	----------------

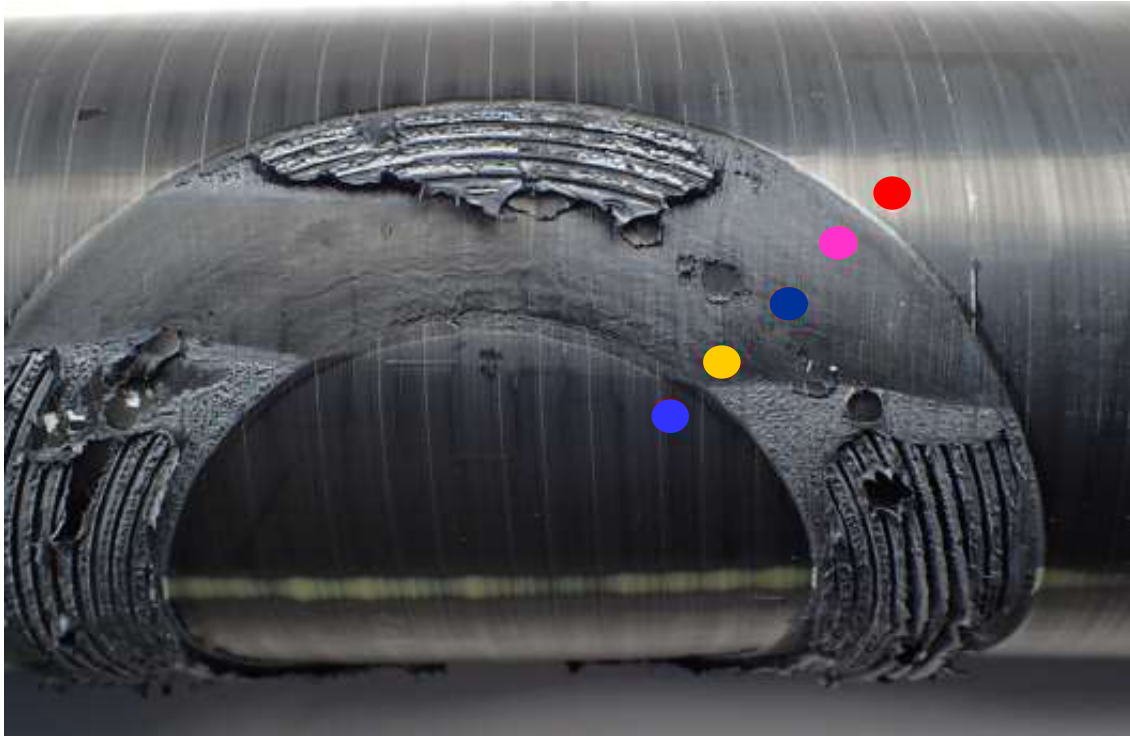

Figure 197. Sample 172316-065, decohesion test result

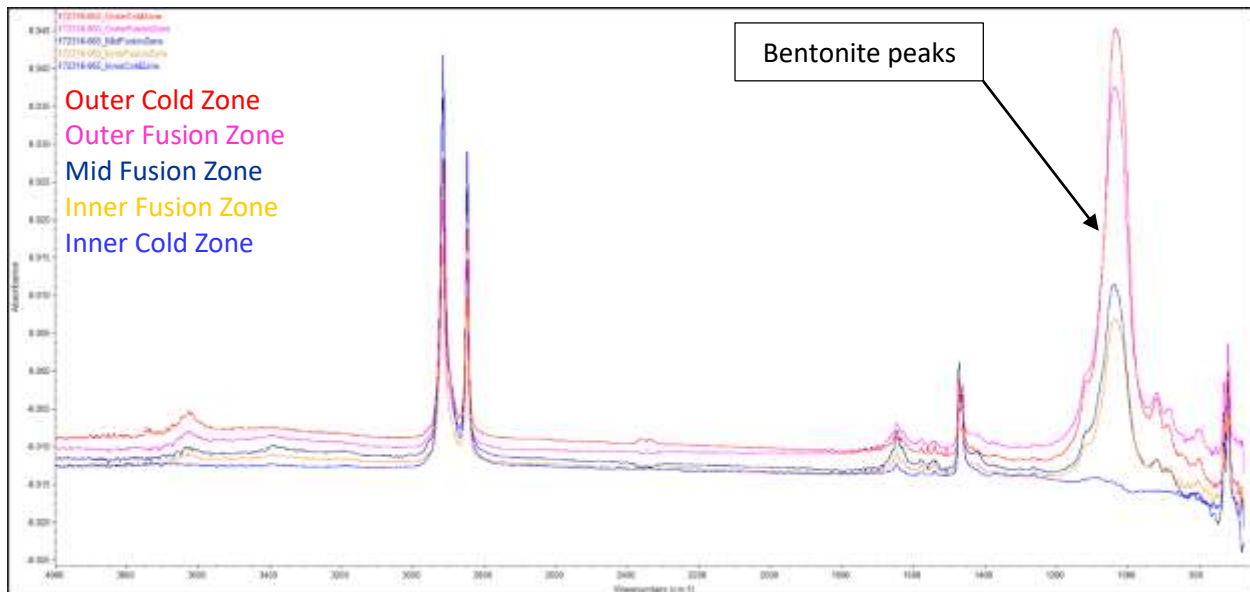

Figure 198. Sample 172316-065, FTIR spectra from decohesion test result

172316-066

172316-066	172395-071	Bentonite	Acetone	Cotton Cloth Rag
------------	------------	-----------	---------	------------------

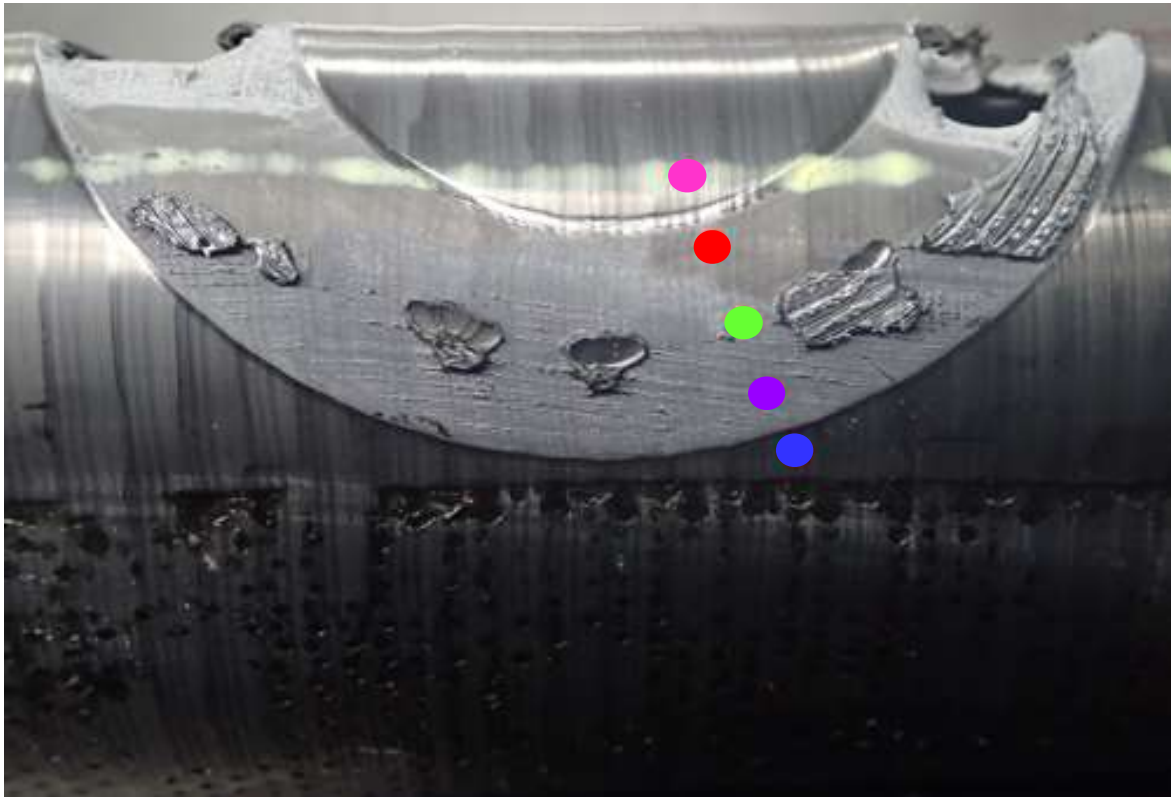

Figure 199. Sample 172316-066, decohesion test result

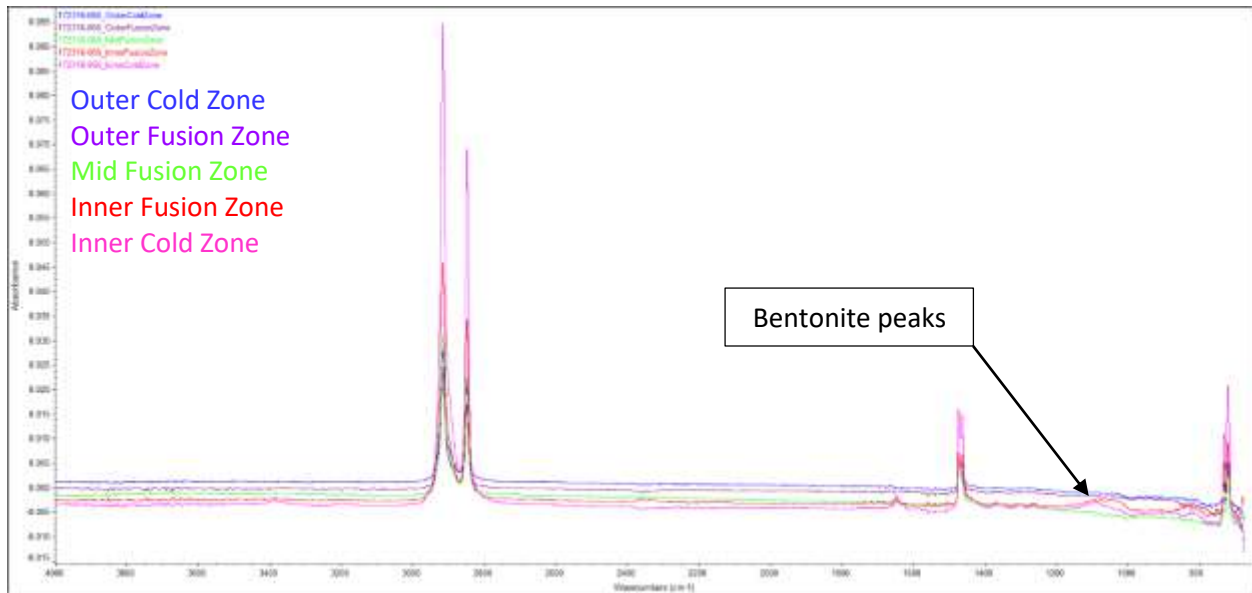

Figure 200. Sample 172316-066, FTIR spectra from decohesion test result

172316-067

172316-067	172395-072	Bentonite	Acetone	Cotton Cloth Rag
------------	------------	-----------	---------	------------------

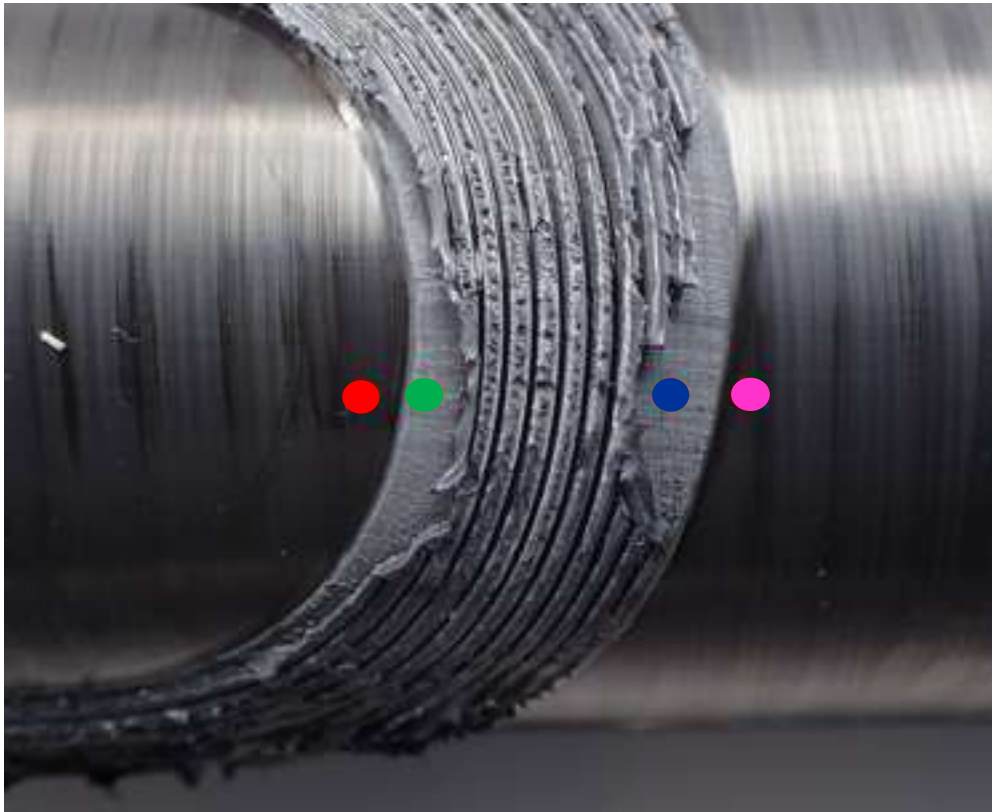

Figure 201. Sample 172316-067, decohesion test result

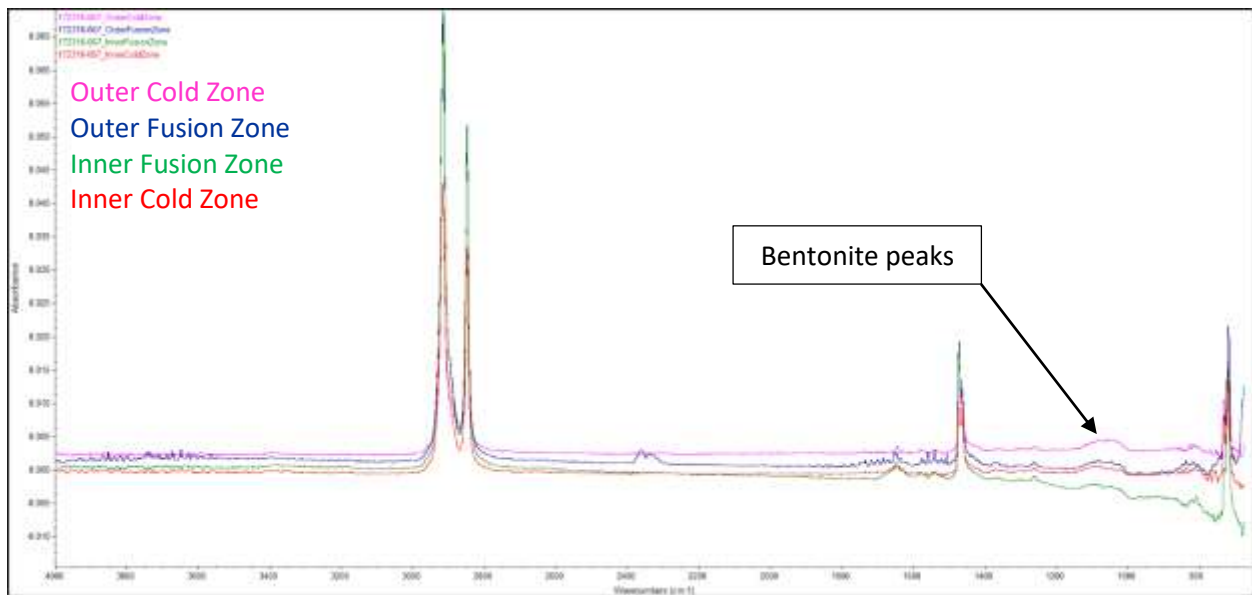

Figure 202. Sample 172316-067, FTIR spectra from decohesion test result

172316-068

172316-068	172395-075	Bentonite	Acetone	Paper Towel
------------	------------	-----------	---------	-------------

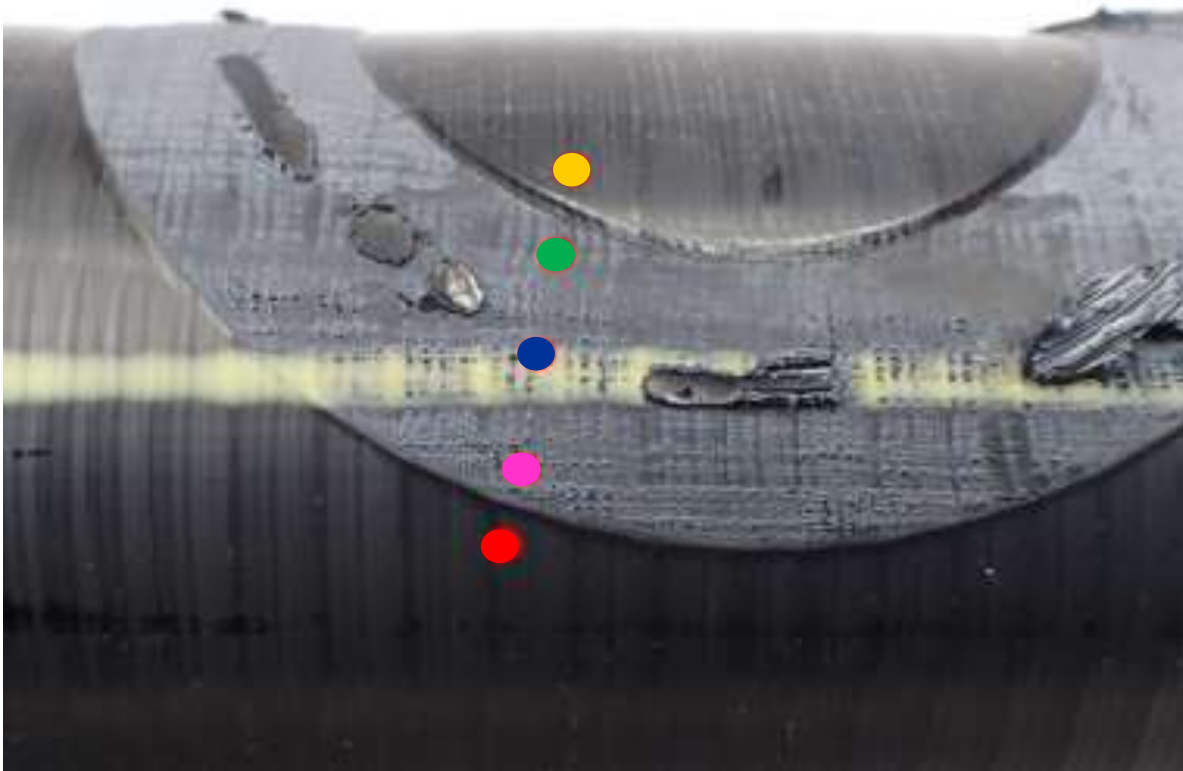

Figure 203. Sample 172316-068, decohesion test result

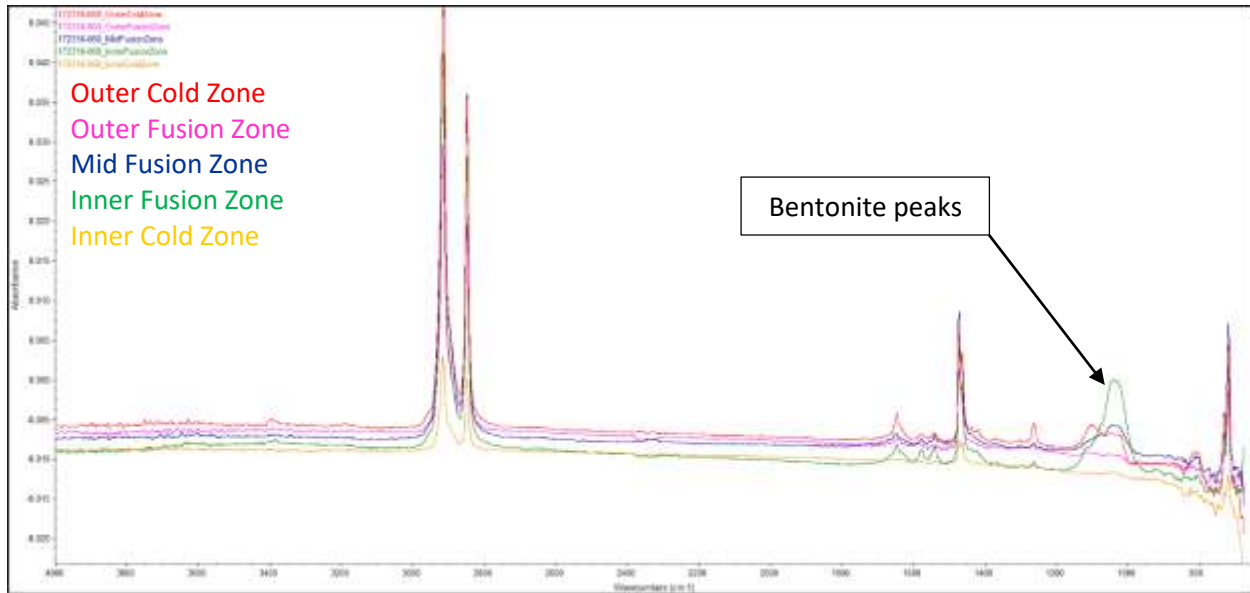

Figure 204. Sample 172316-068, FTIR spectra from decohesion test result

172316-069

172316-069	172395-076	Bentonite	Acetone	Paper Towel
------------	------------	-----------	---------	-------------

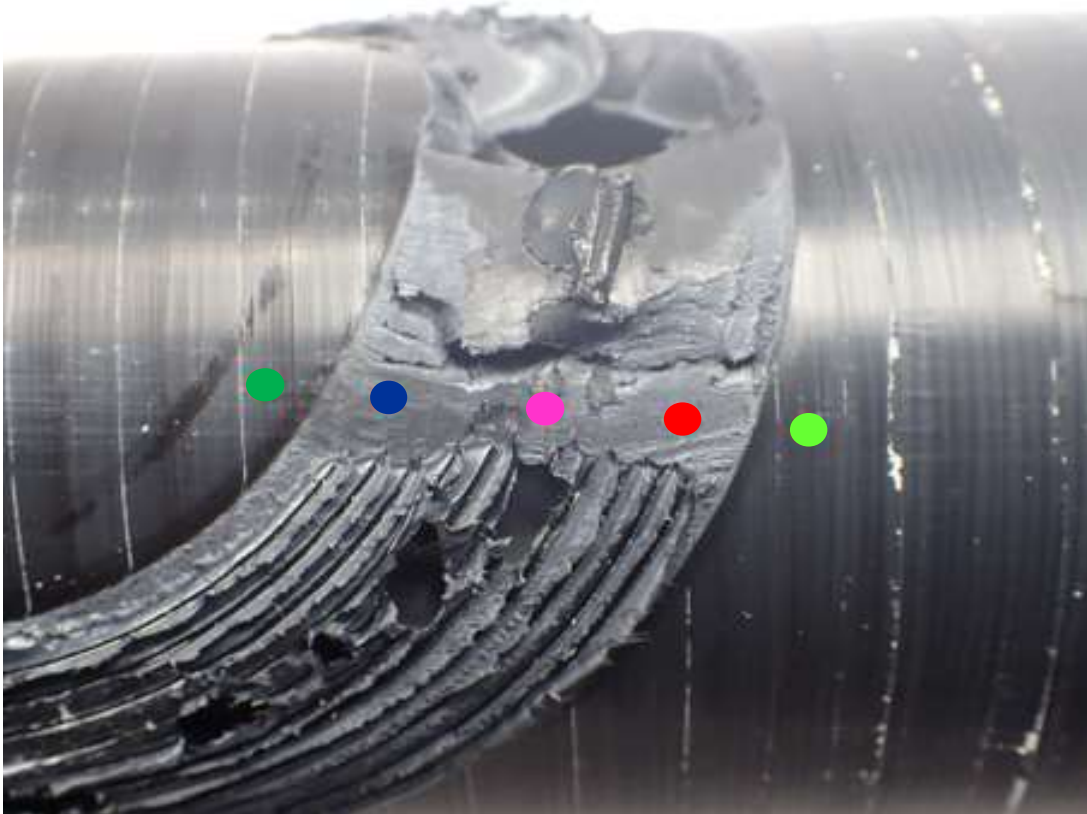

Figure 205. Sample 172316-069, decohesion test result

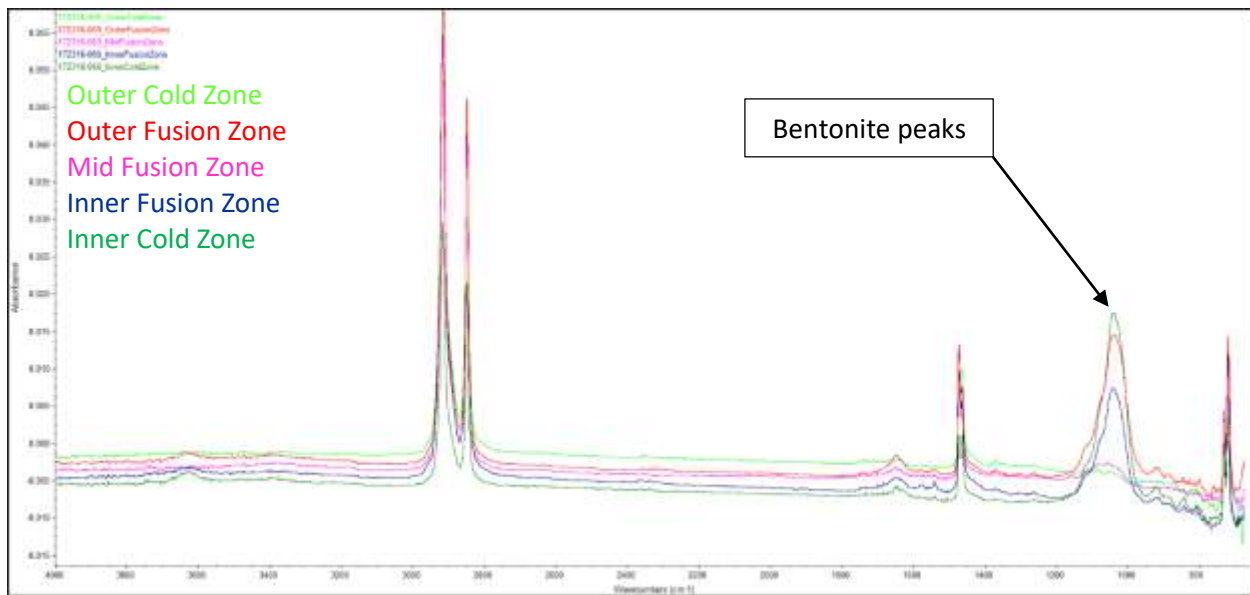

Figure 206. Sample 172316-069, FTIR spectra from decohesion test result

172316-070

172316-070	172395-079	Bentonite	None	None
------------	------------	-----------	------	------



Figure 207. Sample 172316-070, decohesion test result

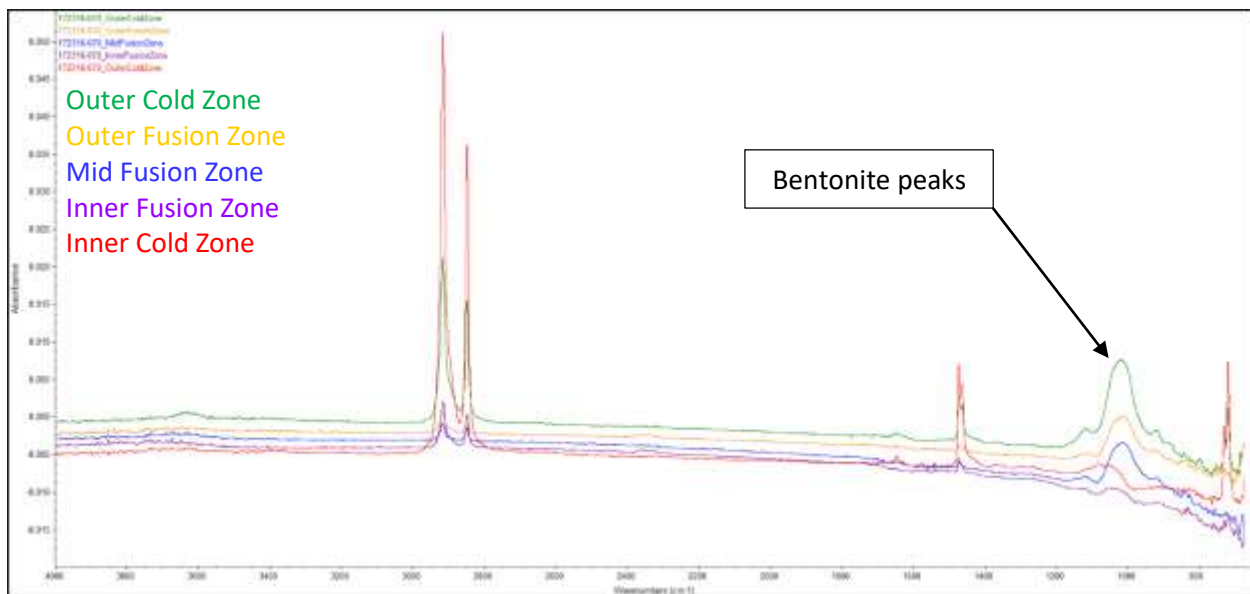

Figure 208. Sample 172316-070, FTIR spectra from decohesion test result

172316-071

172316-071	172395-080	Bentonite	None	None
------------	------------	-----------	------	------



Figure 209. Sample 172316-071, decohesion test result

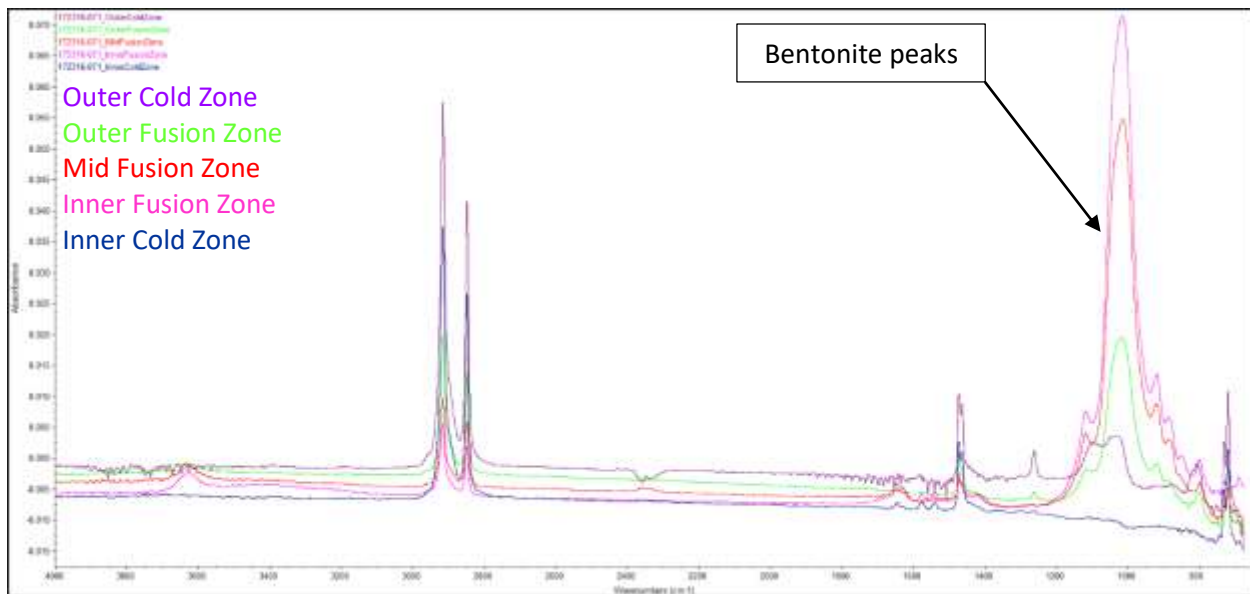

Figure 210. Sample 172316-071, FTIR spectra from decohesion test result

172316-072

172316-072	172395-083	Silicon Grease	99% Isopropanol	Lint-Free Wipe
------------	------------	----------------	-----------------	----------------

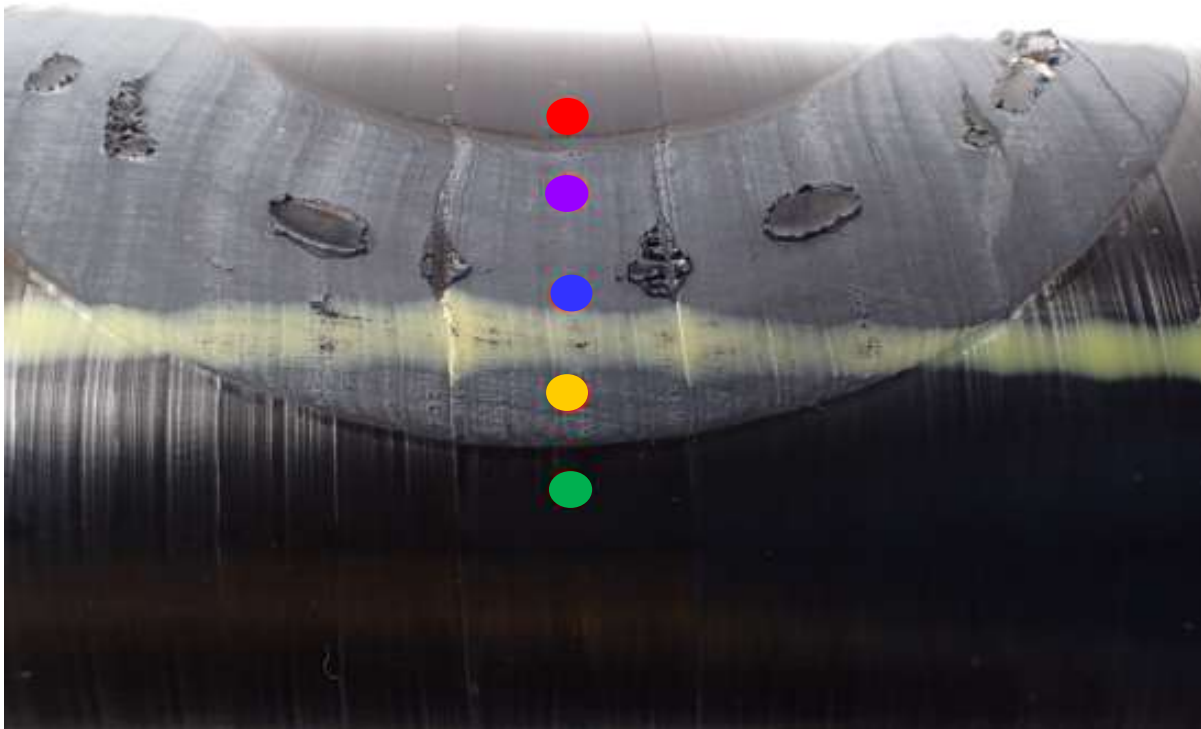

Figure 211. Sample 172316-072, decohesion test result

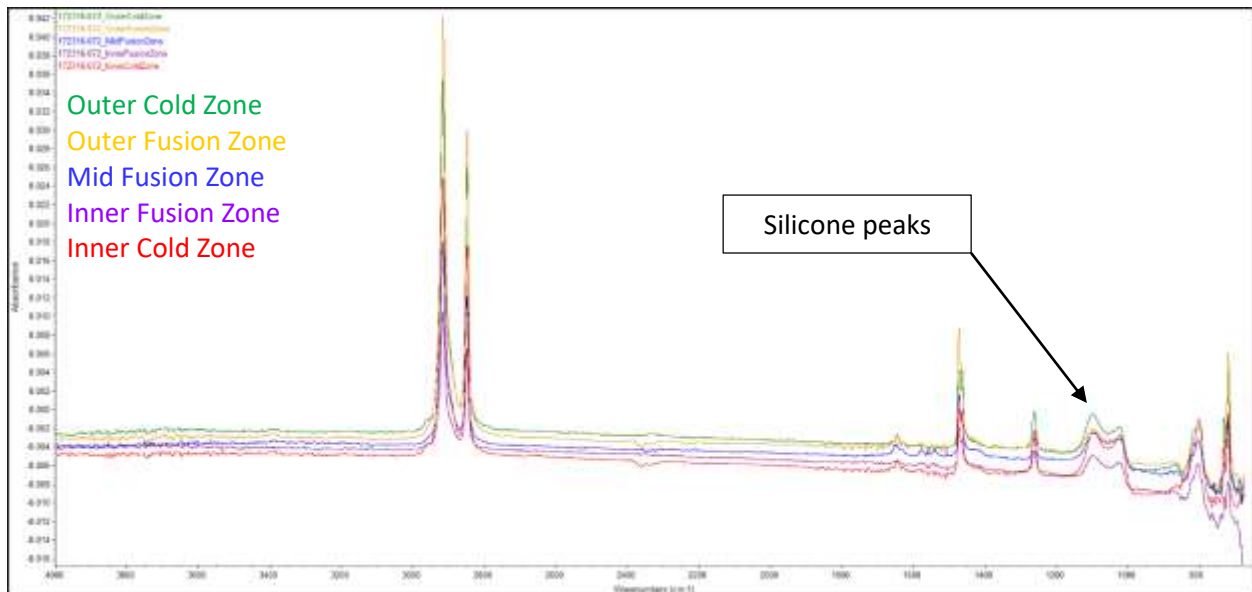

Figure 212. Sample 172316-072, FTIR spectra from decohesion test result

172316-073

172316-073	172395-084	Silicon Grease	99% Isopropanol	Lint-Free Wipe
------------	------------	----------------	-----------------	----------------

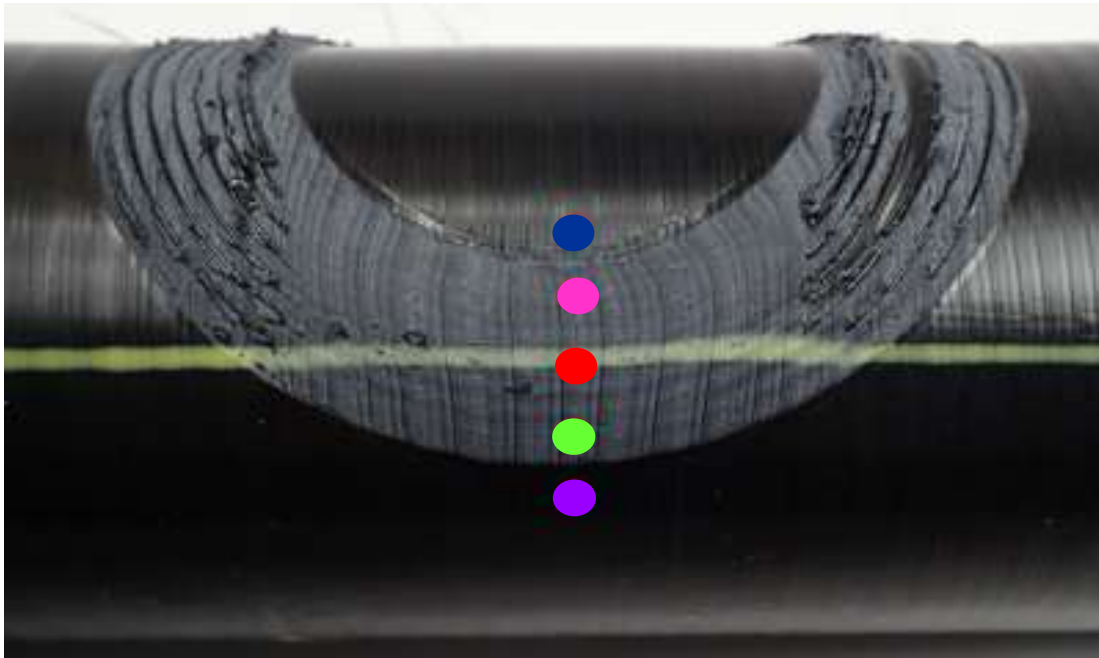

Figure 213. Sample 172316-073, decohesion test result

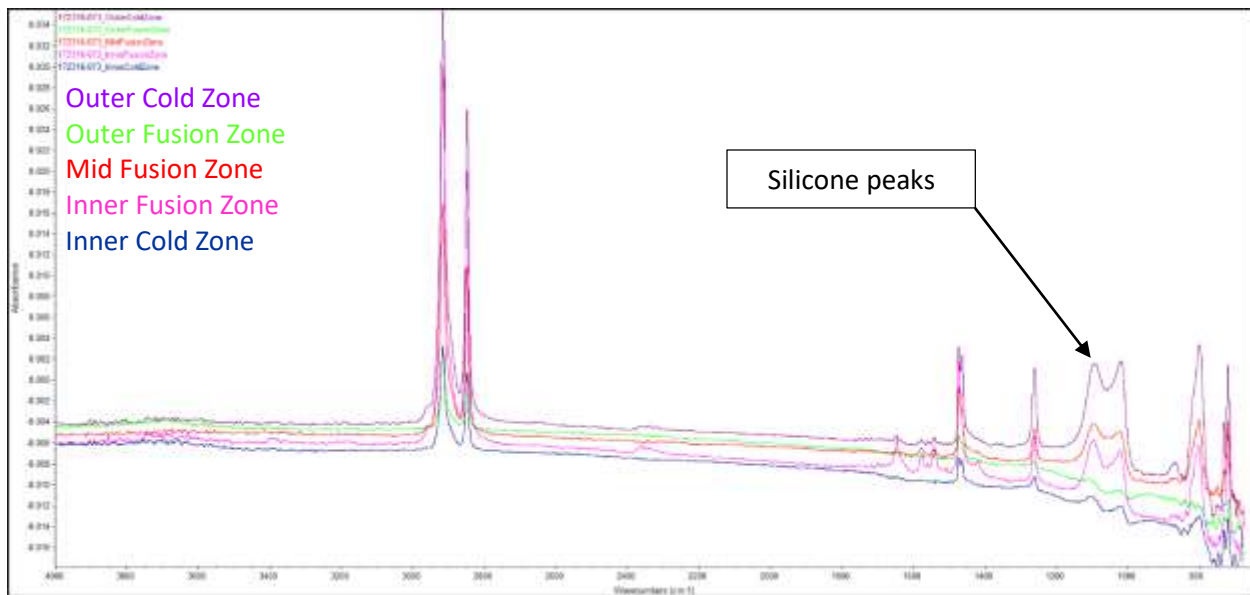

Figure 214. Sample 172316-073, FTIR spectra from decohesion test result

172316-074

172316-074	172395-088	Silicon Grease	Acetone	Lint-Free Wipe
------------	------------	----------------	---------	----------------



Figure 215. Sample 172316-074, decohesion test result

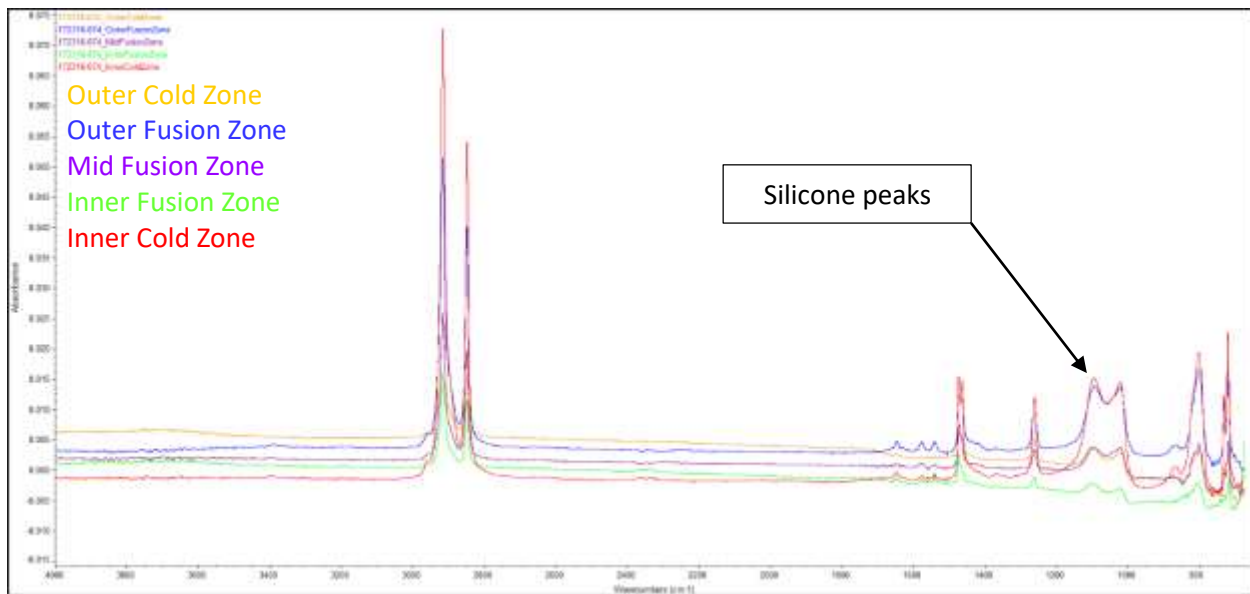

Figure 216. Sample 172316-074, FTIR spectra from decohesion test result

172316-075

172316-075	172395-089	Silicon Grease	Acetone	Lint-Free Wipe
------------	------------	----------------	---------	----------------



Figure 217. Sample 172316-075, decohesion test result

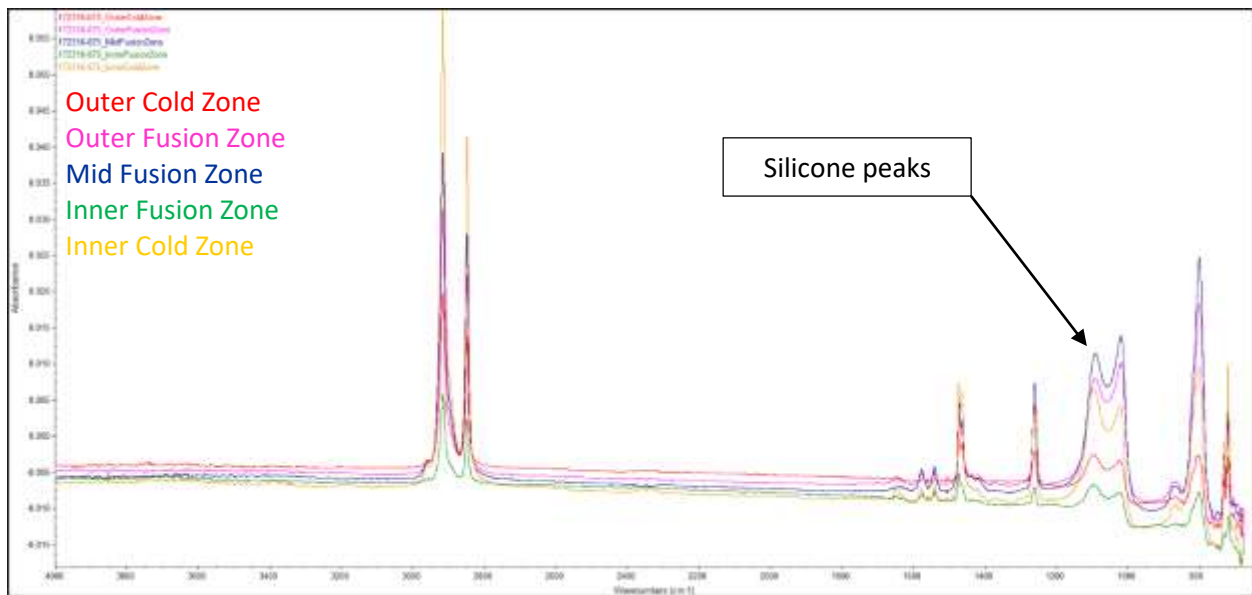

Figure 218. Sample 172316-075, FTIR spectra from decohesion test result

172316-076

172316-076	172395-092	Silicon Grease	Acetone	Cotton Cloth Rag
------------	------------	----------------	---------	------------------

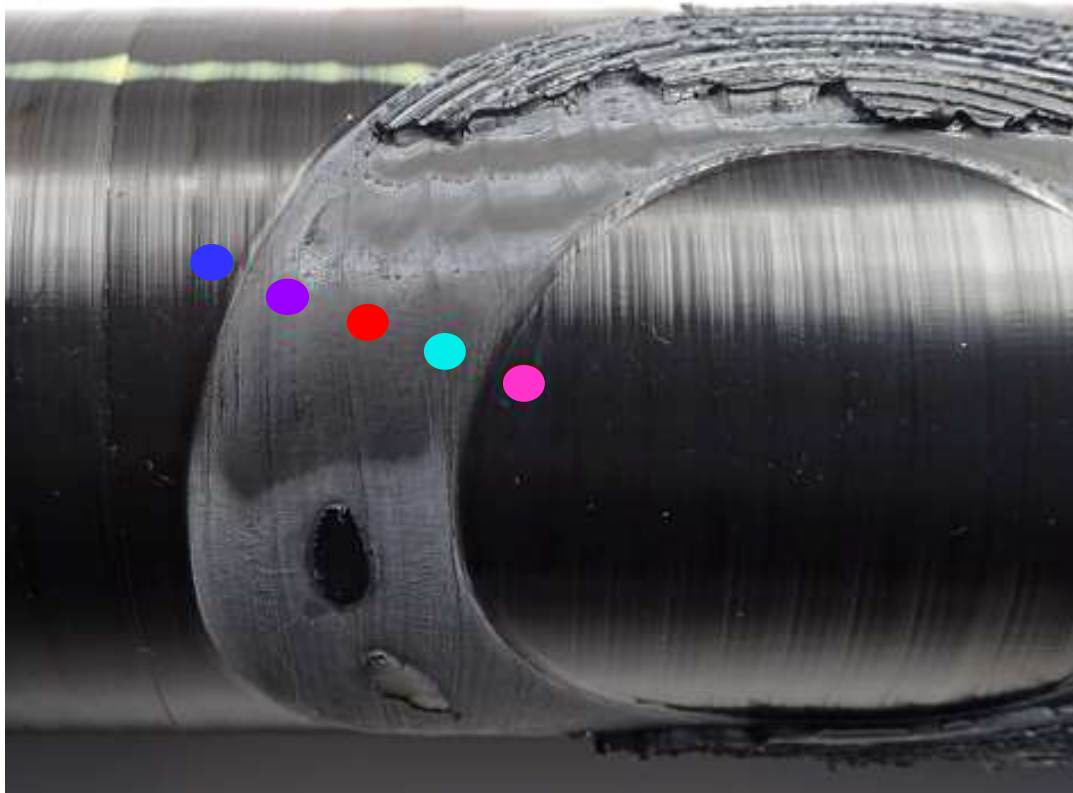

Figure 219. Sample 172316-076, decohesion test result

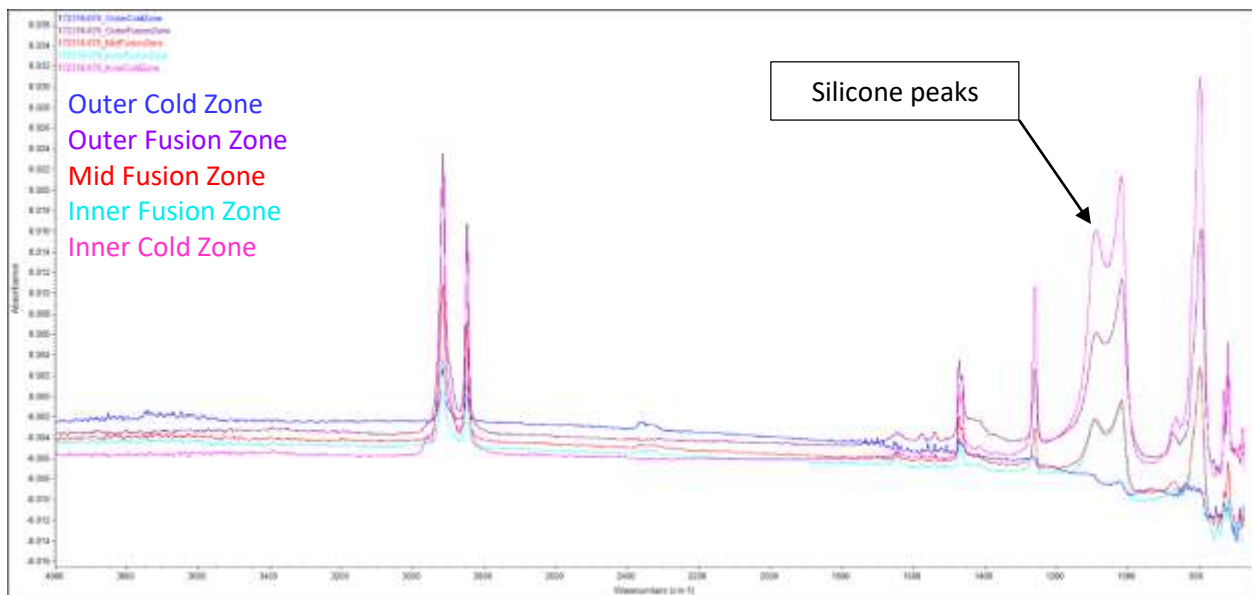

Figure 220. Sample 172316-076, FTIR spectra from decohesion test result

172316-077

172316-077	172395-093	Silicon Grease	Acetone	Cotton Cloth Rag
------------	------------	----------------	---------	------------------

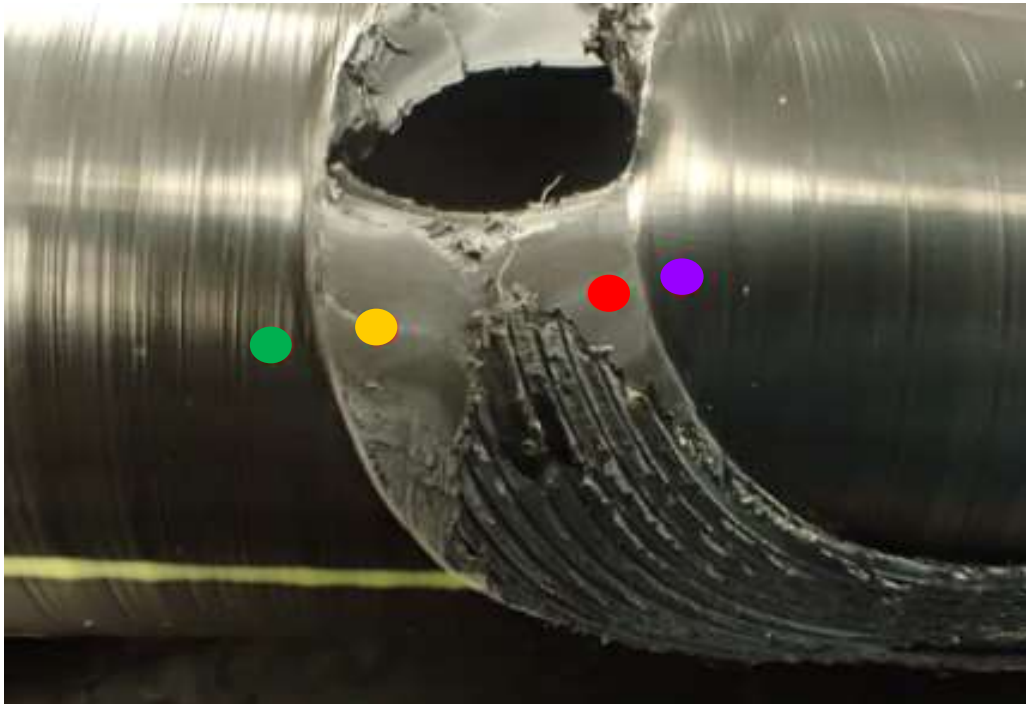

Figure 221. Sample 172316-077, decohesion test result

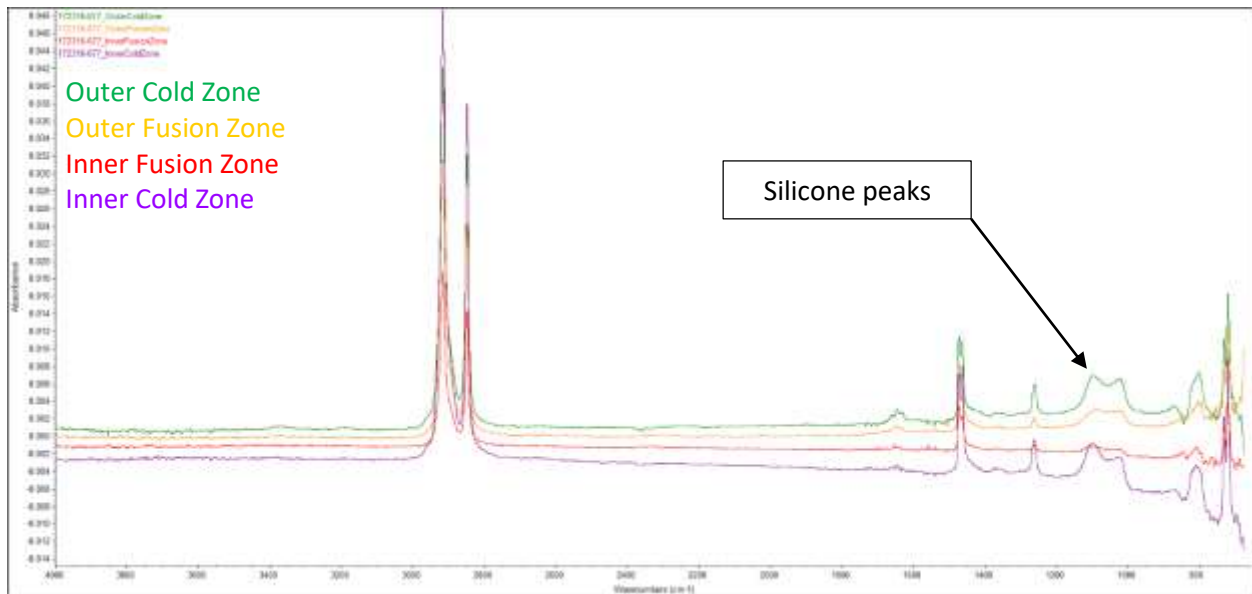

Figure 222. Sample 172316-077, FTIR spectra from decohesion test result

172316-078

172316-078	172395-096	Silicon Grease	Acetone	Paper Towel
------------	------------	----------------	---------	-------------

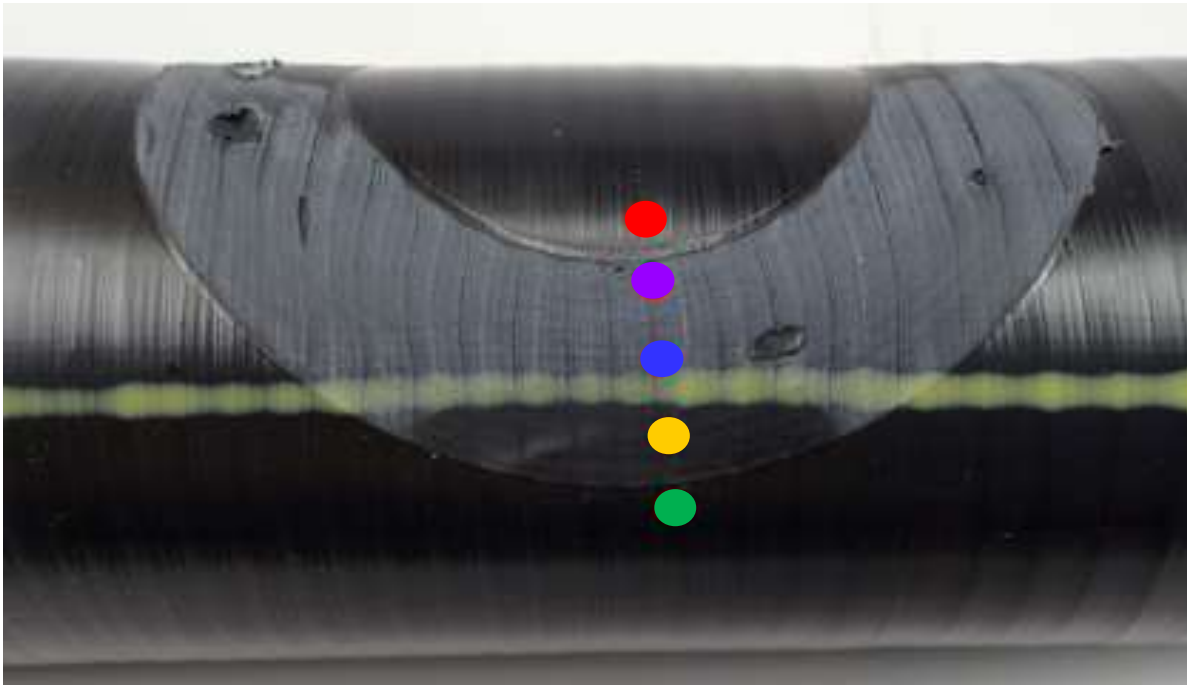

Figure 223. Sample 172316-078, decohesion test result

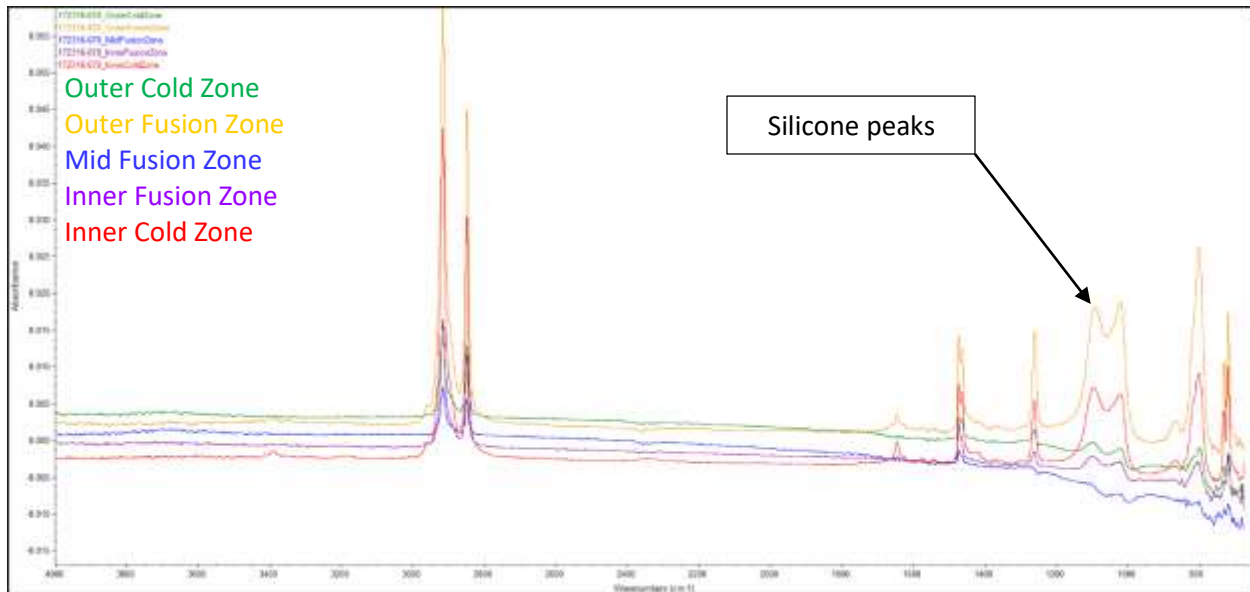

Figure 224. Sample 172316-078, FTIR spectra from decohesion test result

172316-079

172316-079	172395-097	Silicon Grease	Acetone	Paper Towel
------------	------------	----------------	---------	-------------

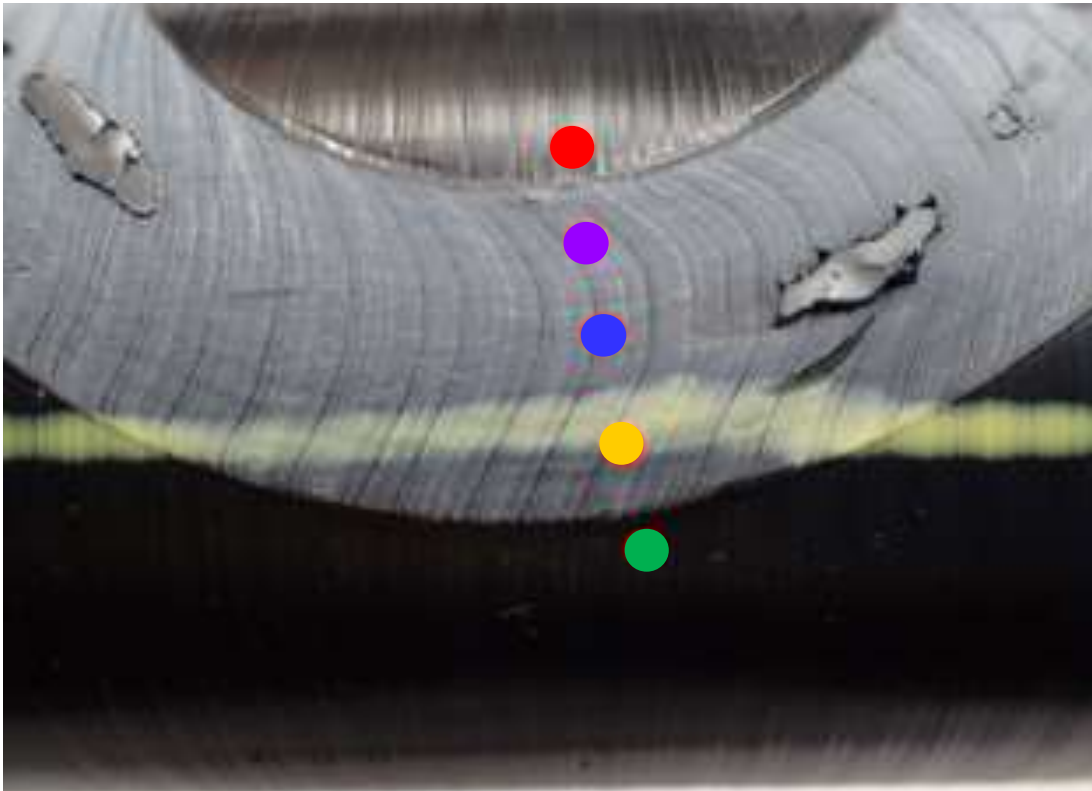

Figure 225. Sample 172316-079, decohesion test result

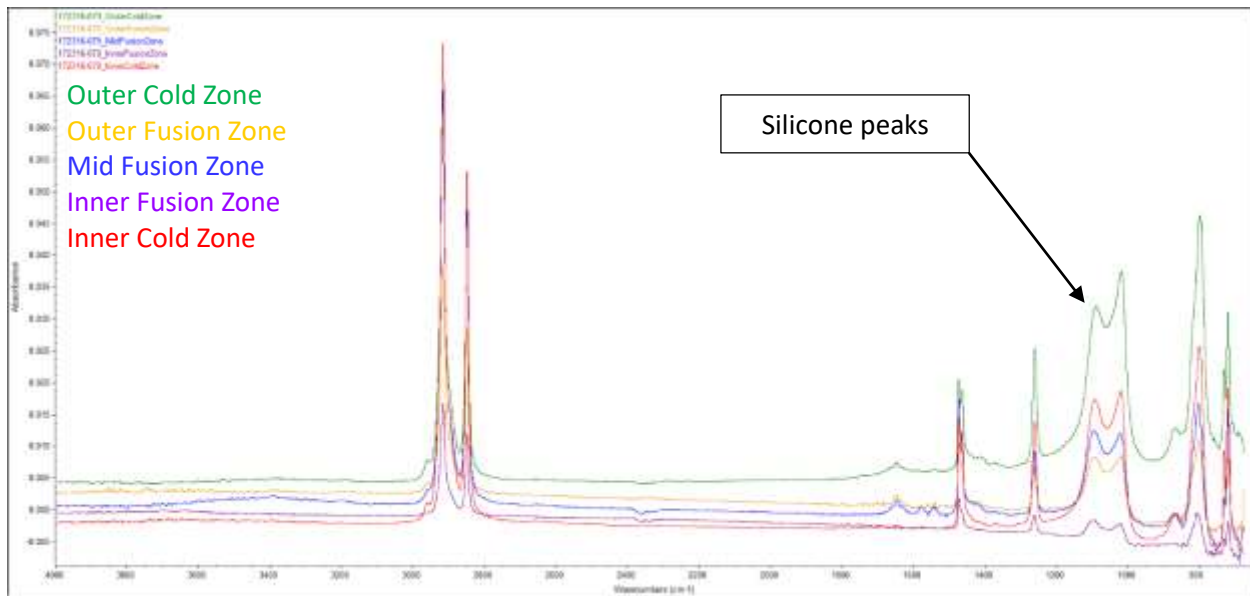

Figure 226. Sample 172316-079, FTIR spectra from decohesion test result

END OF REPORT

**Operations Technology
Development, NFP**

1700 South Mount Prospect Road
Des Plaines, Illinois 60018-1804
847-544-3400
FAX: 847-544-3401

© 2018 Operations Technology
Development, NFP
All rights reserved